

**Wichita Area Regional Intelligent Transportation  
System (ITS) Architecture  
Version 1.1**

**VOLUME 3  
COMMUNICATIONS PLAN**

Submitted by



In association with



**March 17, 2006**

## Table of Contents

<b>1</b>	<b>INTRODUCTION.....</b>	<b>1</b>
<b>2</b>	<b>AGENCY/ELEMENT NEEDS ASSESSMENT .....</b>	<b>3</b>
2.1	*47-KHP .....	4
2.2	*KTA .....	5
2.3	AIR QUALITY ALERT SYSTEM AND AIR QUALITY SENSORS.....	6
2.4	CITY OF ANDOVER 911 AND CITY OF ANDOVER PUBLIC SAFETY VEHICLES .....	6
2.5	CITY OF ANDOVER TOC AND CITY OF ANDOVER ROADSIDE EQUIPMENT .....	8
2.6	COMMERCIAL VEHICLES.....	10
2.7	HAZMAT RESPONSE VEHICLE .....	11
2.8	HEALTHCARE FACILITIES.....	11
2.9	JABARA AIRPORT .....	12
2.10	KANSAS 511 SYSTEM .....	13
2.11	KANSAS BUREAU OF INVESTIGATION (KBI) SYSTEM .....	14
2.12	KANSAS CRIMINAL JUSTICE INFORMATION SYSTEM (KCJIS).....	15
2.13	KANSAS CVO CHECK STATIONS .....	16
2.14	KANSAS HIGHWAY PATROL DISPATCH.....	17
2.15	KANSAS TRUCKING CONNECTION.....	21
2.16	KANSAS TURNPIKE AUTHORITY CENTER.....	21
2.17	KANSAS TURNPIKE AUTHORITY ENVIRONMENTAL SENSORS STATIONS.....	25
2.18	KDOT MAINTENANCE VEHICLE.....	26
2.19	KDOT PLANNING ARCHIVE .....	26
2.20	KDOT TOC INFORMATION SYSTEM .....	27
2.21	KDOT TOC (WICHITA METRO) KIOSKS.....	29
2.22	KDOT TOC (WICHITA METRO) MAINTENANCE AND CONSTRUCTION SYSTEM	30
2.23	KDOT TOC (WICHITA METRO) ROADSIDE EQUIPMENT .....	32
2.24	KDOT TRAFFIC OPERATIONS CENTER (WICHITA METRO).....	33
2.25	KHP TURNPIKE DISPATCH SYSTEM.....	38
2.26	KHP TURNPIKE VEHICLES.....	40
2.27	KHP VEHICLES.....	41
2.28	KTA MAINTENANCE VEHICLE .....	42
2.29	KTA MOTORIST ASSISTANCE PATROL VEHICLES.....	43
2.30	KTA TOLL COLLECTION EQUIPMENT .....	44
2.31	MEDIA .....	45
2.32	MOTORIST ASSISTANCE PATROL VEHICLES.....	46
2.33	NATIONAL WARNING SYSTEM (NAWAS).....	47
2.34	NATIONAL WEATHER SERVICE .....	48
2.35	OFFICE OF CENTRAL INSPECTION (EVENT PERMITS).....	49
2.36	PERSONAL INFORMATION ACCESS DEVICES .....	50
2.37	SCADA.....	51
2.38	SEDGWICK COUNTY 911 .....	52
2.39	SEDGWICK COUNTY EMS VEHICLES.....	55
2.40	SEDGWICK COUNTY FIRE VEHICLES .....	56
2.41	SEDGWICK COUNTY GOVERNMENT DATA REPOSITORY .....	57
2.42	SEDGWICK COUNTY MAINTENANCE AND CONSTRUCTION SYSTEM.....	58

2.43	SEDGWICK COUNTY MAINTENANCE AND CONSTRUCTION VEHICLES .....	61
2.44	SEDGWICK COUNTY SHERIFF VEHICLES .....	62
2.45	SEDGWICK COUNTY TOC ROADSIDE EQUIPMENT .....	63
2.46	SEDGWICK COUNTY TRANSPORTATION BROKERAGE SYSTEM AND VEHICLES ..	64
2.47	SUBURBAN EMERGENCY DISPATCH CENTERS .....	65
2.48	SUBURBAN MAINTENANCE AND CONSTRUCTION SYSTEM.....	67
2.49	SUBURBAN PUBLIC SAFETY VEHICLES .....	68
2.50	SURFACE TRANSPORTATION WEATHER SERVICE PROVIDERS.....	69
2.51	VEHICLE .....	70
2.52	WAYSIDE EQUIPMENT (RAILROAD GATES).....	71
2.53	WICHITA CONSTRUCTION AND MAINTENANCE VEHICLES .....	72
2.54	WICHITA CONSTRUCTION AND MAINTENANCE SYSTEM .....	73
2.55	WICHITA FIRE VEHICLES .....	76
2.56	WICHITA FLOOD MONITORING SYSTEM.....	77
2.57	WICHITA GOVERNMENT DATA REPOSITORY .....	78
2.58	WICHITA MID-CONTINENT AIRPORT .....	79
2.59	WICHITA PARKS AND RECREATION SYSTEM.....	80
2.60	WICHITA POLICE VEHICLES .....	81
2.61	WICHITA TOC ROADSIDE EQUIPMENT .....	82
2.62	WICHITA TRAFFIC OPERATIONS CENTER.....	83
2.63	WICHITA TRANSIT CUSTOMER INFORMATION SYSTEM (CIS) .....	85
2.64	WICHITA TRANSIT KIOSK .....	86
2.65	WICHITA TRANSIT OPERATIONS CENTER.....	87
2.66	WICHITA TRANSIT VEHICLES.....	91
<b>3</b>	<b>EXISTING REGIONAL COMMUNICATIONS INFRASTRUCTURE.....</b>	<b>93</b>
3.1	CABLED SOLUTIONS .....	93
3.2	WIRELESS SOLUTIONS .....	95
3.3	APPLICATION INFRASTRUCTURE RELATIONSHIP .....	98
3.4	COMPARATIVE ANALYSIS .....	98
<b>4</b>	<b>PLANNED COMMUNICATIONS RESOURCES.....</b>	<b>101</b>
4.1	CABLED SOLUTIONS .....	101
4.2	WIRELESS SOLUTIONS .....	101
4.2.1	<i>Dataradio</i> .....	101
4.2.2	<i>WiMax</i> .....	101
4.2.3	<i>Leased Service</i> .....	104
4.3	HYBRID SOLUTION.....	106
4.4	800 MHZ VOICE RADIO SYSTEM.....	108
<b>5</b>	<b>COMMUNICATIONS NEEDS ANALYSIS AND REQUIREMENTS .....</b>	<b>109</b>
<b>6</b>	<b>NETWORK ARCHITECTURE OPTIONS.....</b>	<b>116</b>
	<b>APPENDIX A – LEASED CELLULAR COVERAGE MAPS .....</b>	<b>129</b>
	<b>APPENDIX B – SEDGWICK COUNTY NETWORK REMOTE SITES.....</b>	<b>133</b>

## Table of Figures

Figure 1. *47 Kansas Highway Patrol Communications Diagram .....	5
Figure 2. *KTA Communications Diagram.....	5
Figure 3. Air Quality Alert System Communications Diagram .....	6
Figure 4. City of Andover 911 and Public Safety Vehicles Communications Diagram ...	7
Figure 5. City of Andover TOC and Roadside Equipment Communications Diagram ....	9
Figure 6. Commercial Vehicle Communications Diagram.....	10
Figure 7. HAZMAT Response Vehicle Communications Diagram.....	11
Figure 8. Healthcare Facilities Communications Diagram.....	12
Figure 9. Jabara Airport Communications Diagram.....	13
Figure 10. Kansas 511 System Communications Diagram .....	14
Figure 11. Kansas Bureau of Investigation (KBI) System Communications Diagram ...	15
Figure 12. Kansas Criminal Justice Information System (KCJIS) Communications Diagram.....	16
Figure 13. Kansas CVO Check Stations Communications Diagram.....	17
Figure 14. Kansas Highway Patrol Dispatch Communications Diagram (Part 1).....	18
Figure 15. Kansas Highway Patrol Dispatch Communications Diagram (Part 2).....	19
Figure 16. Kansas Highway Patrol Dispatch Communications Diagram (Part 3).....	20
Figure 17. Kansas Trucking Connection Communications Diagram .....	21
Figure 18. Kansas Turnpike Authority Center Communications Diagram (Part 1) .....	22
Figure 19. Kansas Turnpike Authority Center Communications Diagram (Part 2) .....	23
Figure 20. Kansas Turnpike Authority Center Communications Diagram (Part 3) .....	24
Figure 21. Kansas Turnpike Authority Environmental Sensor Stations Diagram.....	25
Figure 22. KDOT Maintenance Vehicle Communications Diagram.....	26
Figure 23. KDOT Planning Archive Communications Diagram.....	27
Figure 24. KDOT TOC Information System Communications Diagram.....	28
Figure 25. KDOT TOC (Wichita Metro) Kiosks Communications Diagram .....	29
Figure 26. KDOT TOC (Wichita Metro) Maintenance and Construction System Communications Diagram (Part 1) .....	30
Figure 27. KDOT TOC (Wichita Metro) Maintenance and Construction System Communications Diagram (Part 2) .....	31
Figure 28. KDOT TOC (Wichita Metro) Maintenance and Construction System Communications Diagram (Part 3) .....	32
Figure 29. KDOT TOC (Wichita Metro) Roadside Equipment Communications Diagram .....	33
Figure 30. KDOT Traffic Operations Center (Wichita Metro) Communications Diagram (Part 1) .....	35
Figure 31. KDOT Traffic Operations Center (Wichita Metro) Communications Diagram (Part 2) .....	36
Figure 32. KDOT Traffic Operations Center (Wichita Metro) Communications Diagram (Part 3) .....	37
Figure 33. KHP Turnpike Dispatch System Communications Diagram (Part 1).....	38
Figure 34. KHP Turnpike Dispatch System Communications Diagram (Part 2).....	39
Figure 35. KHP Turnpike Dispatch System Communications Diagram (Part 3).....	40

Figure 36. KHP Turnpike Vehicles Communications Diagram .....	41
Figure 37. KHP Vehicles Communications Diagram.....	42
Figure 38. KTA Maintenance Vehicle Communications Diagram .....	43
Figure 39. KTA Motorist Assistance Patrol Vehicles Communications Diagram .....	44
Figure 40. KTA Toll Collection Equipment Communications Diagram.....	45
Figure 41. Media Communications Diagram.....	46
Figure 42. Motorist Assistance Patrol (MAP) Vehicles Communications Diagram.....	47
Figure 43. National Warning System (NAWAS) Communications Diagram.....	48
Figure 44. National Weather Service Communications Diagram .....	49
Figure 45. Office of Central Inspection (Event Permits) Communications Diagram.....	50
Figure 46. Personal Information Access Device Communications Diagram .....	51
Figure 47. SCADA Communications Diagram .....	52
Figure 48. Sedgwick County 911 Diagram (Part 1) .....	53
Figure 49. Sedgwick County 911 Diagram (Part 2) .....	54
Figure 50. Sedgwick County 911 Diagram (Part 3) .....	55
Figure 51. Sedgwick County EMS Vehicles Diagram .....	56
Figure 52. Sedgwick County Fire Vehicles Diagram .....	57
Figure 53. Sedgwick County Government Data Repository Diagram .....	58
Figure 54. Sedgwick County Maintenance and Construction System.....	59
Figure 55. Sedgwick County Maintenance and Construction System.....	60
Figure 56. Sedgwick County Maintenance and Construction System.....	61
Figure 57. Sedgwick County Maintenance and Construction Vehicles Diagram .....	62
Figure 58. Sedgwick County Sheriff Vehicles Diagram .....	63
Figure 59. Sedgwick County TOC Roadside Equipment Diagram .....	64
Figure 60. Sedgwick County Transportation Brokerage System and Vehicles Diagram	65
Figure 61. Suburban Emergency Dispatch Centers Diagram (Part 1).....	66
Figure 62. Suburban Emergency Dispatch Centers Diagram (Part 2).....	67
Figure 63. Suburban Maintenance and Construction System Diagram.....	68
Figure 64. Suburban Public Safety Vehicles Diagram .....	69
Figure 65. Surface Transportation Weather Service Providers Communications Diagram .....	70
Figure 66. Vehicle Communications Diagram .....	71
Figure 67. Wayside Equipment (Railroad Gates) Communications Diagram.....	72
Figure 68. Wichita Construction and Maintenance Vehicles Communications Diagram	73
Figure 69. Wichita Construction and Maintenance System Communications Diagram (Part 1) .....	74
Figure 70. Wichita Construction and Maintenance System Communications Diagram (Part 2) .....	75
Figure 71. Wichita Construction and Maintenance System Communications Diagram (Part 3) .....	76
Figure 72. Wichita Fire Vehicles Communications Diagram.....	77
Figure 73. Wichita Flood Monitoring System Communications Diagram.....	78
Figure 74. Wichita Government Data Repository Communications Diagram .....	79
Figure 75. Wichita Mid-Continent Airport Communications Diagram.....	80
Figure 76. Wichita Parks and Recreation System Communications Diagram .....	81
Figure 77. Wichita Police Vehicles Communications Diagram .....	82

Figure 78. Wichita TOC Roadside Equipment Diagram .....	83
Figure 79. Wichita Traffic Operations Center (TOC) Communications Diagram (Part 1) .....	84
Figure 80. Wichita Traffic Operations Center (TOC) Communications .....	85
Figure 81. Wichita Transit Customer Information System (CIS) Communications Diagram.....	86
Figure 82. Wichita Transit Kiosk Communications Diagram .....	87
Figure 83. Wichita Transit Operations Center Communications Diagram (Part 1) .....	88
Figure 84. Wichita Transit Operations Center Communications Diagram (Part 2) .....	89
Figure 85. Wichita Transit Operations Center Communications Diagram (Part 3) .....	90
Figure 86. Wichita Transit Operations Center Communications Diagram (Part 4) .....	91
Figure 87. Wichita Transit Vehicles Communications Diagram.....	92
Figure 88. KDOT Fiber and Conduit Routes.....	94
Figure 89. Mobile Data System .....	96
Figure 90. Coverage Prediction .....	97
Figure 91. Fully Integrated Hybrid System .....	107
Figure 92. ITS Center Site Locations .....	110
Figure 93. Architecture Generalized Bandwidth .....	114
Figure 94. Nextel Coverage Map.....	129
Figure 95. Verizon Wireless Coverage Map.....	130
Figure 96. T-Mobile Coverage Map .....	131
Figure 97. Cingular Wireless Coverage Map .....	132

## Table of Tables

Table 1. Summary of Land-Line Technologies and Their Features .....	119
Table 2. Advantages and Disadvantages of Twisted-Wire Pairs.....	120
Table 3. Advantages and Disadvantages of Coaxial Cable .....	121
Table 4. Advantages and Disadvantages of Fiber Optic Communications .....	122
Table 5. Wireless Communication Technologies and Their Associated Properties.....	126

## 1 Introduction

In 1998, the Wichita-Sedgwick County region published the Strategic Deployment Plan for Intelligent Transportation Systems (ITS). The purpose of the study was to identify the ITS user services appropriate for the Wichita region and to develop a strategic deployment plan to provide these user services. In 2001, the Wichita-Sedgwick County region participated in the creation of an initial Wichita-Sedgwick County Regional ITS Architecture based on the National ITS Architecture and the 1998 Strategic Deployment Plan. The currently named Wichita Area Regional ITS Architecture project is comprised of three volumes. This document is Volume 3 and contains the Communications Plan based upon the Architecture (Volume 1) and the Implementation Plan (Volume 2). There is a companion web site for the Wichita Area Regional ITS Architecture at [www.iteris.com/wichitaarchitecture](http://www.iteris.com/wichitaarchitecture).

An ITS Architecture provides a blueprint of how transportation systems within the region will be identified and interconnected. During the development of the architecture, a number of communications needs were expressed by the participating stakeholders and the functionality contained in the Regional ITS Architecture. By defining the role and anticipated automated ITS activities of each agency, the architecture establishes pathways of data that must be carried by a communications infrastructure.

This Volume 3 Communications Plan document contains the communications system requirements and framework based on the interface described in the regional ITS architecture. The Communications Plan will help guide the Wichita region in their planning needs for their envisioned surface transportation services.

This document is a direct result of stakeholder meetings held in Wichita where participants discussed in detail the existing and future information exchanges between surface transportation systems which were captured in the Wichita Area Regional ITS Architecture. In addition, the Mobile Data and Automatic Vehicle Location Needs Assessment and Alternatives Analysis Report dated June 2003 was referenced for its mobile communications content. Section 2 of this document provides a comprehensive element needs assessment showing all the interface flows around each element. Section 3 describes currently available communications resources. Section 4 contains planned communication resources. Section 5 analyzes these communication needs and includes high-level communication requirements for the region. Section 6 provides further analysis and recommendations for possible communication network architecture alternatives.

During the development of the regional architecture, a number of center-to-center, center-to-vehicle and center-to-field communications needs were identified for project development in the near, medium and long-term. This document defines the needs for communication systems based on the data flow requirements established for center-to-center, center-to-vehicle and center-to-field applications.



It is the intent of this document to be a companion to the recently published Mobile Data and Automatic Vehicle Location Needs Assessment and Alternatives Analysis Report which covered mobile communications technologies for an AVL environment. While the Mobile Data document was structured by agency, this communications plan will be structured by ITS element (e.g., center, vehicle, traveler, or field equipment). For a given project, each element included needs to be analyzed with regard to which architecture flows surrounding the element are part of the project. Once the scope of architecture flows interfacing to and from the project (and its elements) are determined, analysis of message realization via ITS standards as well as expected message frequency will all together provide an idea of the bandwidth required for that particular project. Communication services should take into account each individual project as well as other projects that potentially could leverage or share that communication service.

## 2 Agency/Element Needs Assessment

The Agency Needs Assessment was performed by reviewing current communication inventory and the planned projects within the region (near term, mid term and long term) in order to determine the communication needs of the agencies. The benefit of reviewing all of the needs of the agencies at the same time is that it can provide the opportunity for establishing shared communication infrastructure. Although this approach is not always feasible or practical due to institutional, technological or scheduling impacts; it is usually beneficial for the region to consider this approach in the interest of reduced deployment, operations and maintenance costs associated with shared communication infrastructure.

The communication infrastructure currently in place was compared to the needs of the planned projects so that the current communication infrastructure can be leveraged for these projects if it is appropriate. If the current communication infrastructure can support the needs of the planned projects this would represent a significant cost savings for the region.

A communication infrastructure upgrade was also examined. An upgrade involves the use of some of the existing communication infrastructure and upgrading current equipment. A couple of hypothetical examples of communication infrastructure upgrades follow.

- Make use of existing singlemode fiber optic cable and replace the current SONET backhaul OC-3 equipment with an OC-48 platform to provide more bandwidth.
- Make use of existing communication towers and shelter facilities and replace the low-speed microwave links with relatively high-speed 155 Mbps microwave links.

The aforementioned items are only examples and are not actual recommendations for the region. These hypothetical examples leveraged existing communication infrastructure.

The use of new communication infrastructure was also examined. With new ITS deployments, it is likely that new communication infrastructure will be required as ITS equipment is placed in geographical areas that currently do not have agency communication infrastructure. As agencies become interconnected in order to exchange data for the purpose of providing better transportation systems for the region, it is likely that new communication infrastructure will be required to meet the needs of the projects.

It is also important to understand that certain ITS field devices require more bandwidth than others. For example, a single CCTV camera requires from approximately 0.2 Mbps to 6 Mbps depending on the resolution, frame rate and compression techniques. A single traffic signal controller typically only requires approximately 4800 bps (0.0048 Mbps). By comparison, a single analog CCTV camera requires approximately 1,250 times more bandwidth than a typical traffic signal controller. Since there is such a wide range of bandwidth needs among ITS field hardware it is important that the stakeholders share as much information as possible with the Regional Architecture Development Team so that the communication needs of the region are adequately addressed.

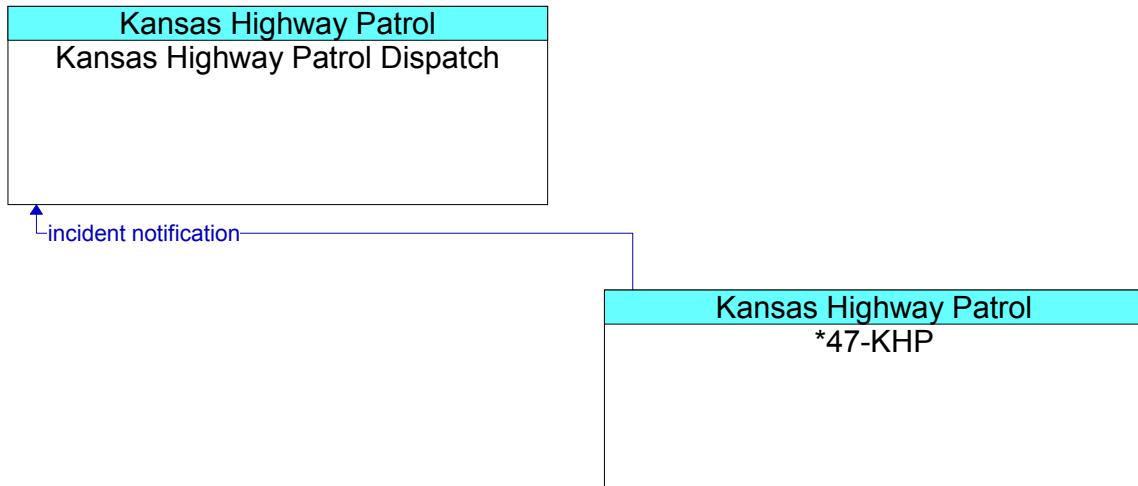
The scope of this communication plan is intended for ITS communication devices and bound by a timeframe of 0 to 20 years. As mentioned above, the Architecture Development Team will attempt to identify opportunities for the use of common communication infrastructure at the project level. In the field, communication infrastructure often has very close ties to specific locations.

Sections 3 and 4 of this document identify the existing and planned communication needs of the agencies and the respective location of existing communication infrastructure as well as the general location of each project and the interconnecting facilities. Sections 5 and 6 of this document identify the communication needs analysis and requirements considerations (including bandwidth) and the communication architecture options. Collectively, the aforementioned information is used to generate the communication planning information. This Communications Plan will set the foundation for the ITS communication infrastructure for the Wichita region for the next 20 years.

The following information summarizes the communication needs of the agencies by ITS element or system. The description, status and architectural mapping of each element can be found in the Wichita Area Regional ITS Architecture Volume 1 document. This information is alphabetically arranged by element. In some cases the figures are not readable due to number of information flows needed by that element (e.g., Figure 47 – Sedgwick County 911 Diagram). The intent of these diagrams is to provide a starting point for evaluating the communications needed for projects involving these elements. For those diagrams that are too complex to put on an 8.5 X 11 sheet of paper it is advised that the project manager be provided with custom diagrams from the Turbo Architecture software tool based on the particular needs for the project.

## **2.1 \*47-KHP**

The following diagram (Figure 1) shows all interfaces in the regional ITS architecture surrounding the \*47-KHP element with annotated timeframes for expected communication content. The associated stakeholders are depicted on the top of each box containing an element.



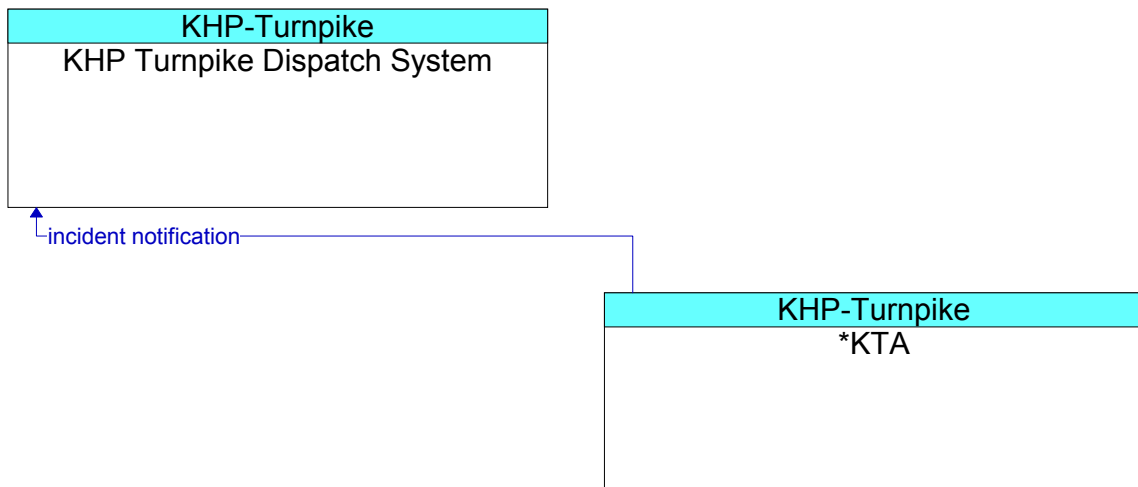
Existing

**Figure 1. \*47 Kansas Highway Patrol Communications Diagram**

The communications received from the \*47 call-in number from the traveling public to the Kansas Highway Patrol Dispatch contains incident information. A phone connection is currently used for communication.

## 2.2 \*KTA

The following diagram (Figure 2) shows all interfaces in the regional ITS architecture surrounding the \*47-KHP element with annotated timeframes for expected communication content. The associated stakeholders are depicted on the top of each box containing an element.



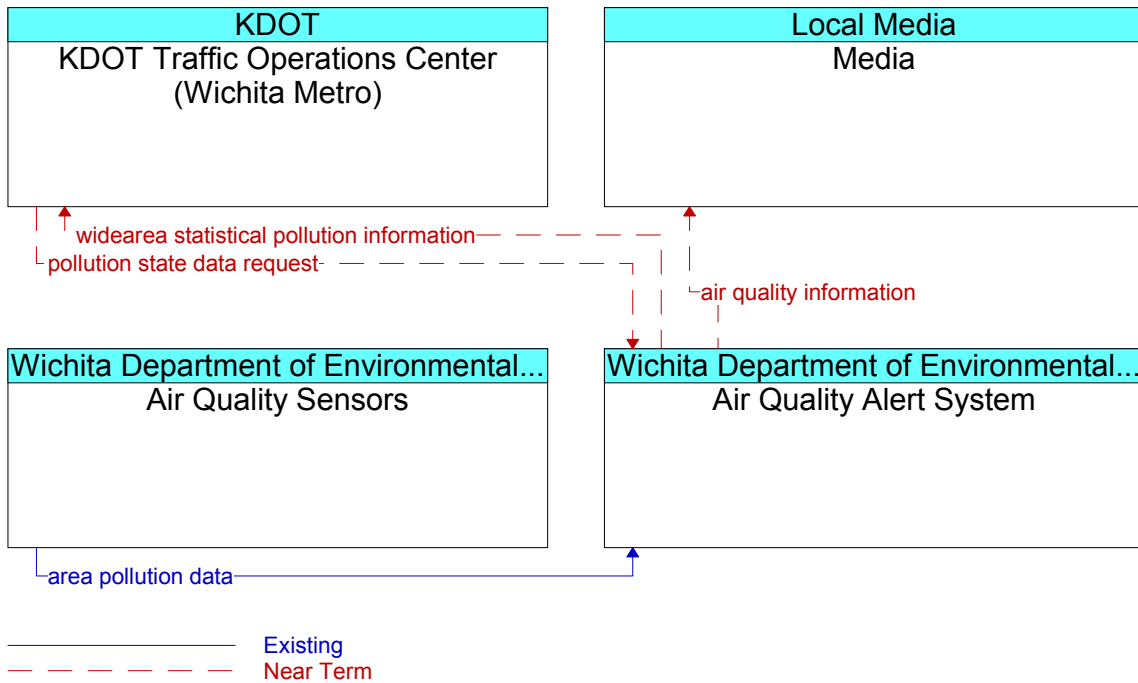
Existing

**Figure 2. \*KTA Communications Diagram**

The communications received from the \*KTA call-in number from the traveling public to the Kansas Highway Patrol Dispatch allocated to the turnpike contains incident information. A phone connection is currently used for communication.

### 2.3 Air Quality Alert System and Air Quality Sensors

The following diagram (Figure 3) shows all interfaces in the regional ITS architecture surrounding the Air Quality Alert System and Air Quality Sensors elements with annotated timeframes for expected communication content. The associated stakeholders are depicted on the top of each box containing an element.



**Figure 3. Air Quality Alert System Communications Diagram**

The communications received from the Air Quality Sensors to the Air Quality Alert System is over dial-up communications lines. In the future there is a need for air quality information to be disseminated.

### 2.4 City of Andover 911 and City of Andover Public Safety Vehicles

The following diagram (Figure 4) shows all interfaces in the regional ITS architecture surrounding the City of Andover 911 system and City of Andover Public Safety elements with annotated timeframes for expected communication content. The associated stakeholders are depicted on the top of each box containing an element.

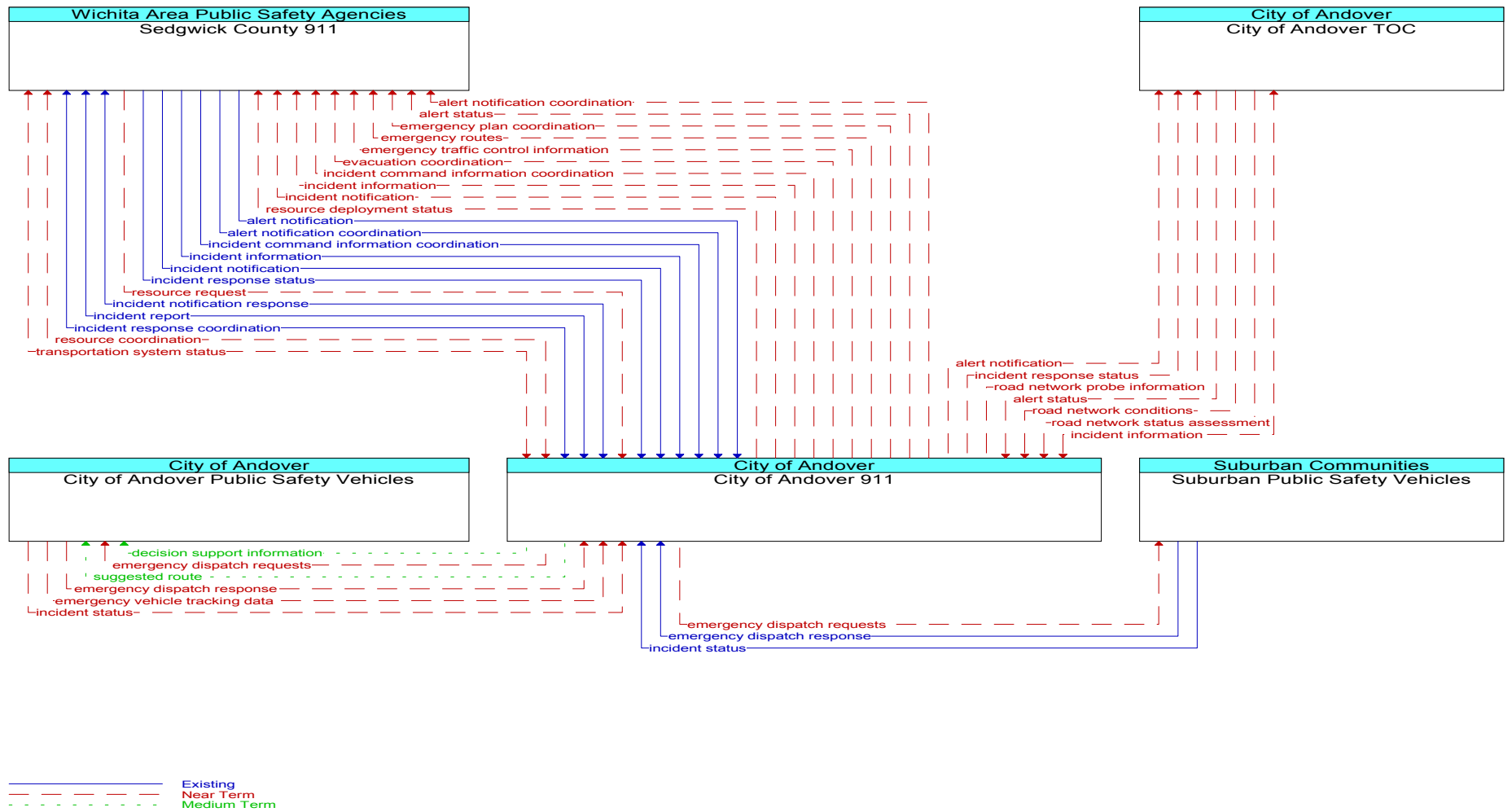
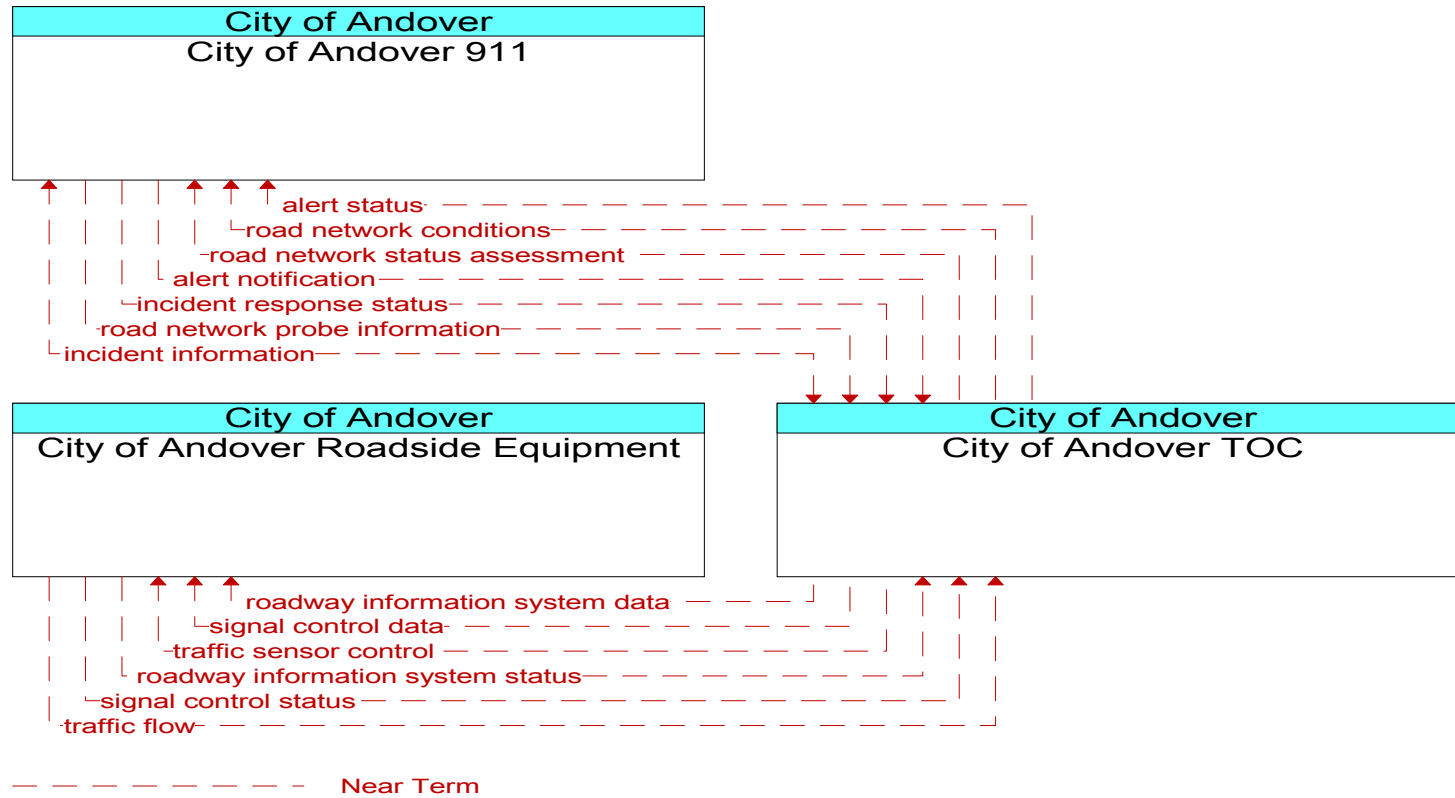


Figure 4. City of Andover 911 and Public Safety Vehicles Communications Diagram

The City of Andover 911 system has existing and future communication with the Sedgwick County 911 system as part of coordinating activities. The City of Andover 911 system also communicates wirelessly with the City of Andover Public Safety Vehicles.

## **2.5 City of Andover TOC and City of Andover Roadside Equipment**

The following diagram (Figure 5) shows all interfaces in the regional ITS architecture surrounding the City of Andover TOC and City of Andover Roadside Equipment elements with annotated timeframes for expected communication content. The associated stakeholders are depicted on the top of each box containing an element.



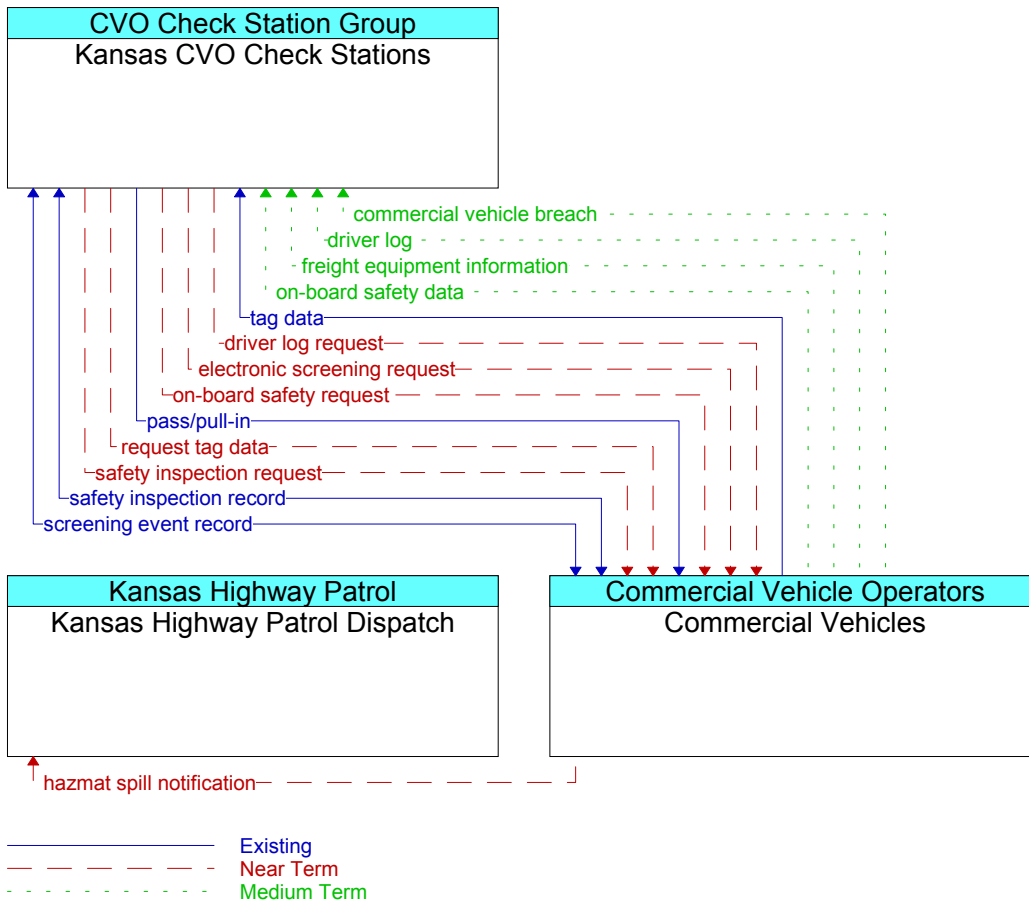
**Figure 5. City of Andover TOC and Roadside Equipment Communications Diagram**



The City of Andover TOC has existing and future communication with the City of Andover 911 system as part of coordinating activities. The City of Andover TOC also communicates through wireline with the City of Andover Roadside Equipment.

## 2.6 Commercial Vehicles

The following diagram (Figure 6) shows all interfaces in the regional ITS architecture surrounding the Commercial Vehicles element with annotated timeframes for expected communication content. The associated stakeholders are depicted on the top of each box containing an element.

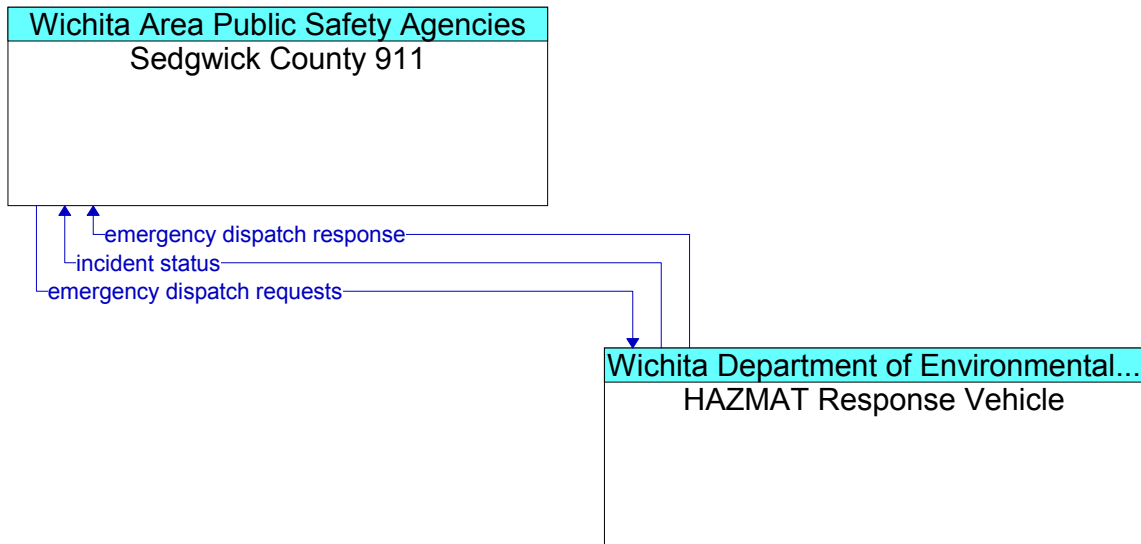


**Figure 6. Commercial Vehicle Communications Diagram**

The Commercial Vehicles currently communicate wirelessly with Kansas CVO Check Stations using the PrePass system. In the near-term there is a need for the vehicles to report HAZMAT spill information to the Kansas Highway Patrol. In the medium-term there is a need to communicate wirelessly other information to the Kansas CVO Check Stations and Fleet and Freight Vehicle Owners.

## 2.7 HAZMAT Response Vehicle

The following diagram (Figure 7) shows all interfaces in the regional ITS architecture surrounding the HAZMAT Response Vehicle element with annotated timeframes for expected communication content. The associated stakeholders are depicted on the top of each box containing an element.



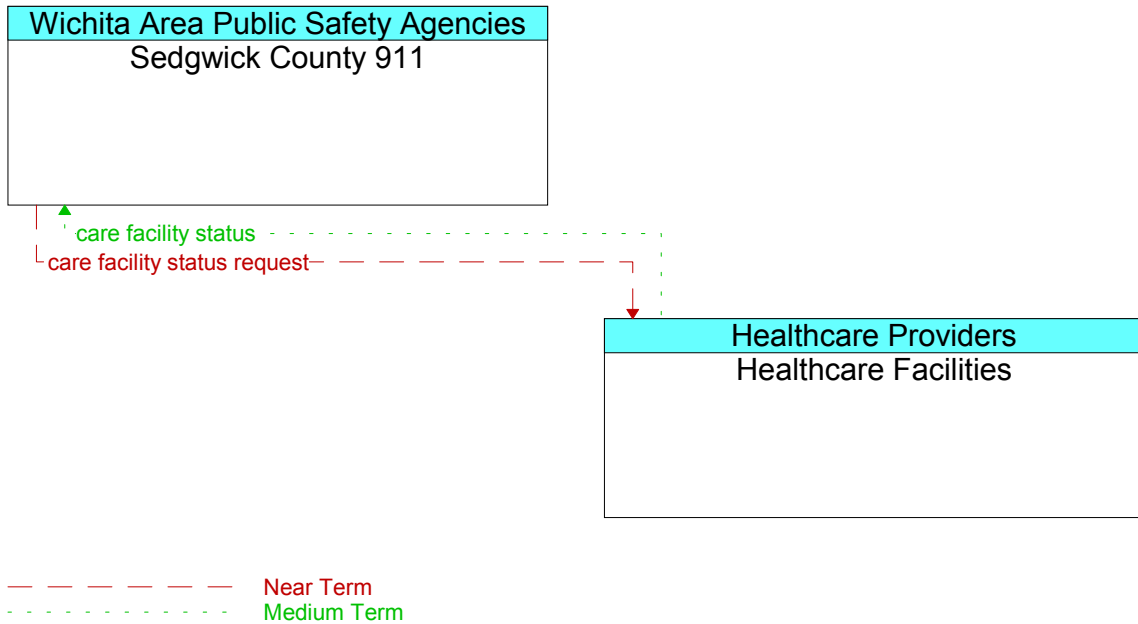
Existing

**Figure 7. HAZMAT Response Vehicle Communications Diagram**

The HAZMAT Response Vehicles currently communicate with Sedgwick County 911 providing the Sedgwick County 911 incident status and emergency dispatch response. This is a wireless communication interface, most likely using 800MHz data exchanges.

## 2.8 Healthcare Facilities

The following diagram (Figure 8) shows all interfaces in the regional ITS architecture surrounding the Healthcare Facilities element with annotated timeframes for expected communication content. The associated stakeholders are depicted on the top of each box containing an element.

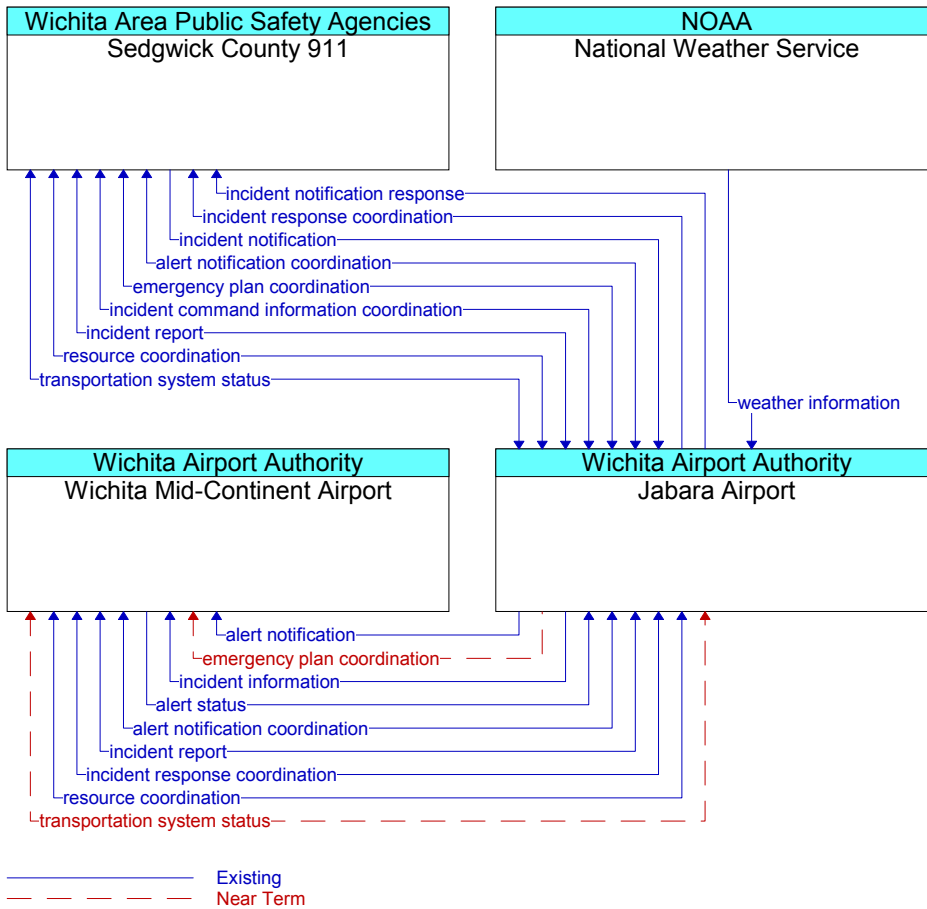


**Figure 8. Healthcare Facilities Communications Diagram**

In the medium-term there is a need for the regional Healthcare Facilities to communicate care facility status to Sedgwick County 911. This is a point-to-point communication interface which could be implemented using local leased line service or a dedicated network.

## 2.9 Jabara Airport

The following diagram (Figure 9) shows all interfaces in the regional ITS architecture surrounding the Jabara Airport element with annotated timeframes for expected communication content. The associated stakeholders are depicted on the top of each box containing an element.

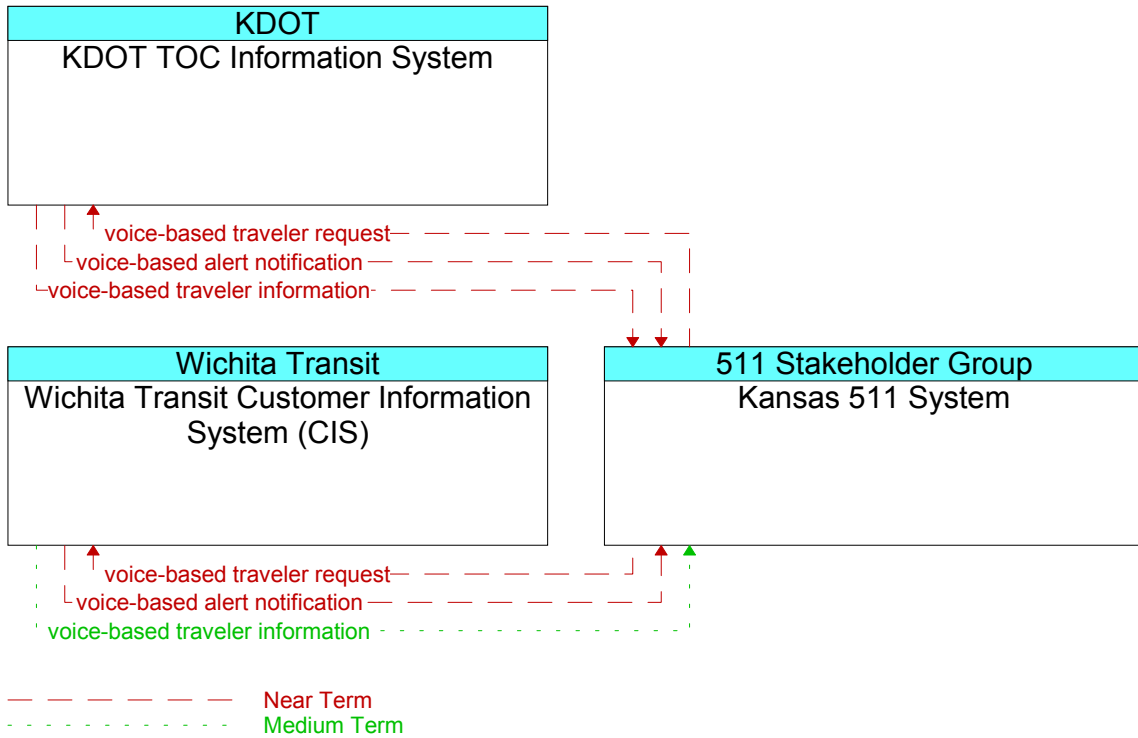


**Figure 9. Jabara Airport Communications Diagram**

The Jabara Airport currently communicates with Sedgwick County 911, Wichita Mid-Continent Airport, and the National Weather Service exchanging incident, alert, coordination, status and response information. In the near-term there is a need for the Jabara Airport and the Wichita Mid-Continent Airport to exchange emergency plan coordination and transportation system status. This is a point-to-point communication interface which could be implemented using local leased line service or a dedicated network.

## 2.10 Kansas 511 System

The following diagram (Figure 10) shows all interfaces in the regional ITS architecture surrounding the Kansas 511 System element with annotated timeframes for expected communication content. The associated stakeholders are depicted on the top of each box containing an element.

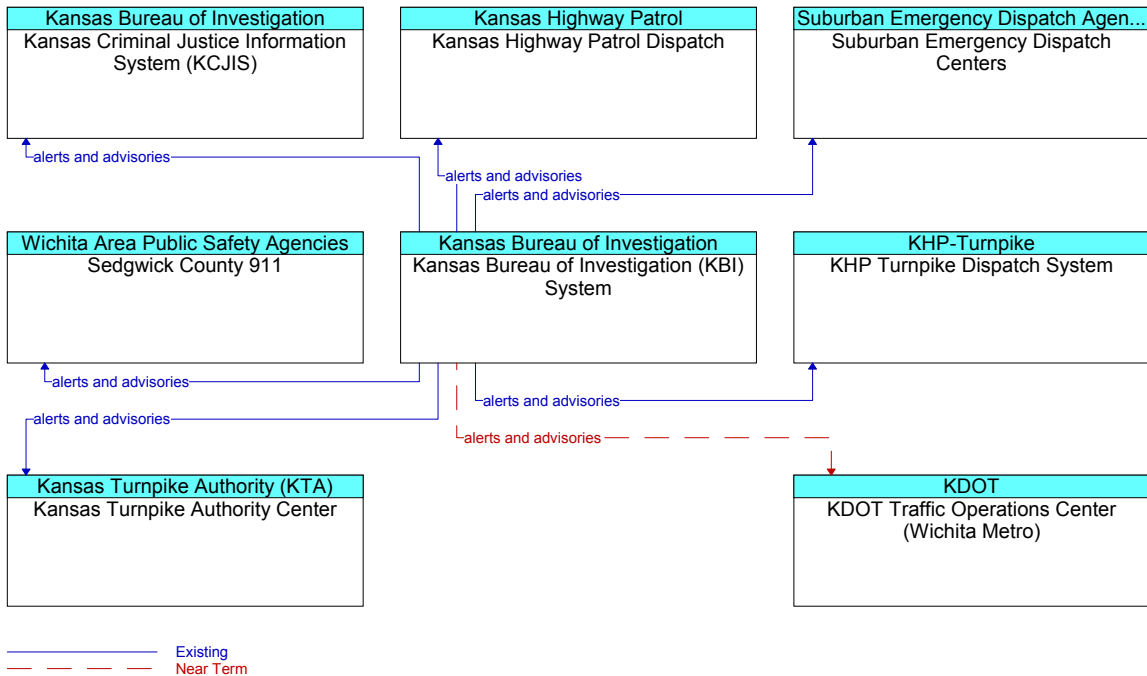


**Figure 10. Kansas 511 System Communications Diagram**

In the near term the Kansas 511 System is in need of receiving voice based alert notification and voice-based traveler information from KDOT TOC Information System as well as voice-based alert notification from Wichita Transit CIS. In the medium-term there is a need to communicate voice-based traveler information from Wichita Transit CIS to the Kansas 511 System. These systems are operated out of centers which are stationary; they represent point-to-point communication interfaces which could be implemented using local leased line service or a dedicated network.

## 2.11 Kansas Bureau of Investigation (KBI) System

The following diagram (Figure 11) shows all interfaces in the regional ITS architecture surrounding the Kansas Bureau of Investigation (KBI) System element with annotated timeframes for expected communication content. The associated stakeholders are depicted on the top of each box containing an element.

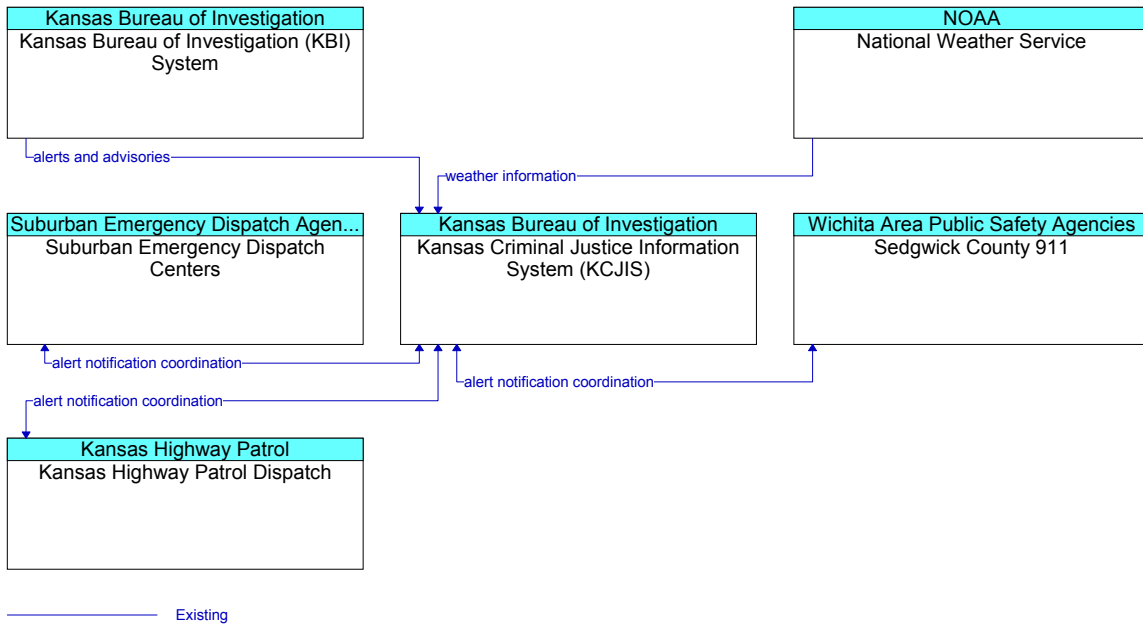


**Figure 11. Kansas Bureau of Investigation (KBI) System Communications Diagram**

The Kansas Bureau of Investigation (KBI) System is currently sending alerts and advisories to several agencies in the Wichita area. In the near term the KBI System is in need of sending alerts and advisories to the KDOT Traffic Operations Center (Wichita Metro). These systems are operated out of centers which are stationary; they represent point-to-point communication interfaces which could be implemented using local leased line service or a dedicated network.

## 2.12 Kansas Criminal Justice Information System (KCJIS)

The following diagram (Figure 12) shows all interfaces in the regional ITS architecture surrounding the Kansas Criminal Justice Information System (KCJIS) element with annotated timeframes for expected communication content. The associated stakeholders are depicted on the top of each box containing an element.

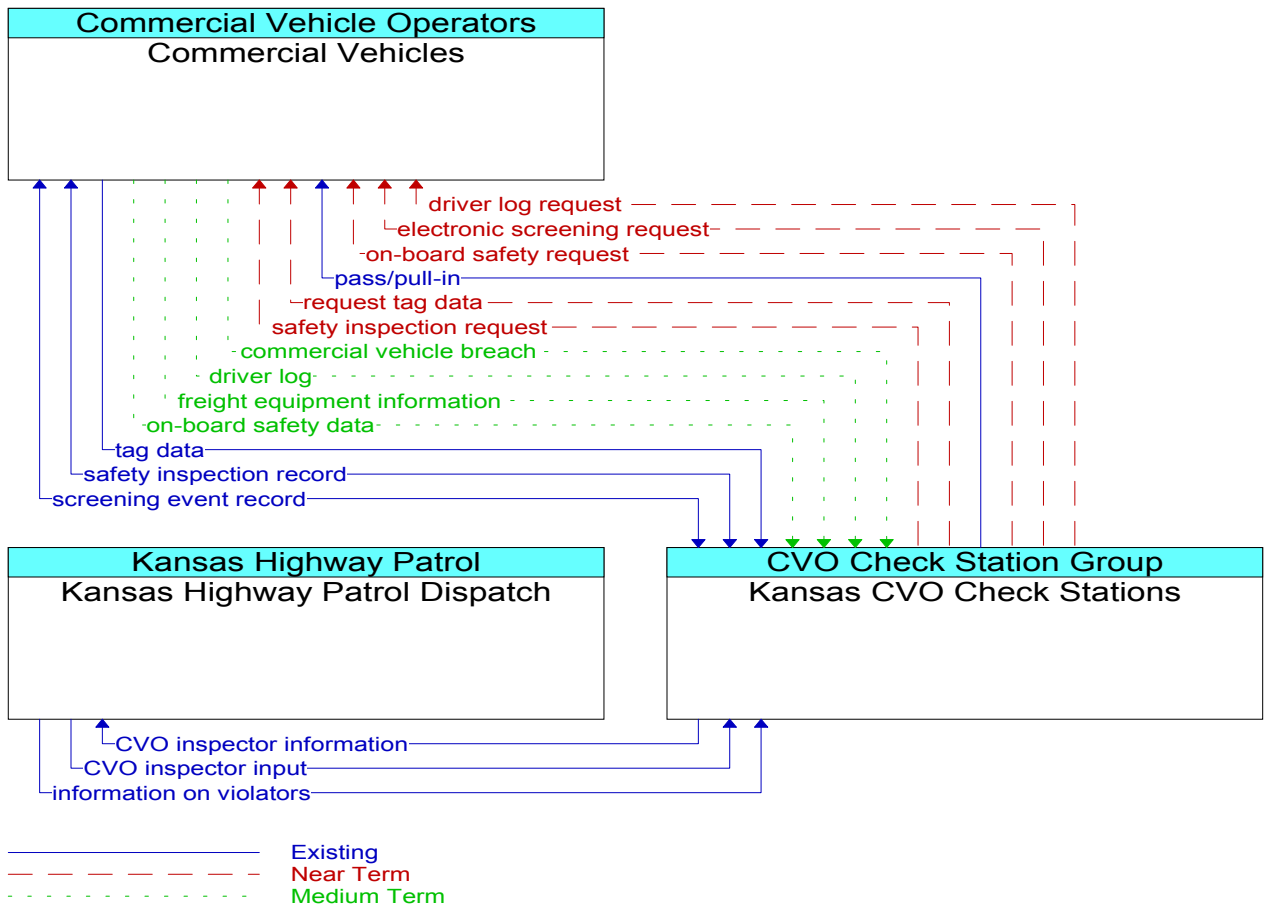


**Figure 12. Kansas Criminal Justice Information System (KCJIS) Communications Diagram**

The Kansas Criminal Justice Information System (KCJIS) currently communicates with the KBI System, National Weather Service, Suburban Emergency Dispatch Centers, Sedgwick County 911 and Kansas Highway Patrol Dispatch. There is no near or medium term need to communicate with other agencies. These systems are operated out of centers which are stationary; they represent point-to-point communication interfaces which may be implemented using local leased line service or a dedicated network.

### 2.13 Kansas CVO Check Stations

The following diagram (Figure 13) shows all interfaces in the regional ITS architecture surrounding the Kansas CVO Check Stations element with annotated timeframes for expected communication content. The associated stakeholders are depicted on the top of each box containing an element.



**Figure 13. Kansas CVO Check Stations Communications Diagram**

The Kansas CVO Check Stations currently communicate with Kansas Highway Patrol Dispatch and Commercial Vehicles. The communication between the Kansas CVO Check Stations and the Kansas Highway Patrol Dispatch represent point-to-point communication interfaces which may be implemented using local leased line service or a dedicated network. The Commercial Vehicles communicate wirelessly with Kansas CVO Check Stations using the PrePass system. In the medium term there is a need for the Commercial Vehicles to report commercial vehicle breach, driver log, freight equipment information and on-board safety data to the Kansas CVO Check Stations. It is planned that the medium term information be transmitted from the Commercial Vehicles to the Kansas CVO Check Stations using the wireless PrePass system.

## 2.14 Kansas Highway Patrol Dispatch

The following diagram (Figure 14, Figure 15 and Figure 16) shows all interfaces in the regional ITS architecture surrounding the Kansas Highway Patrol Dispatch element with annotated timeframes for expected communication content. The associated stakeholders are depicted on the top of each box containing an element.



# Wichita Area Regional ITS Architecture – Volume 3

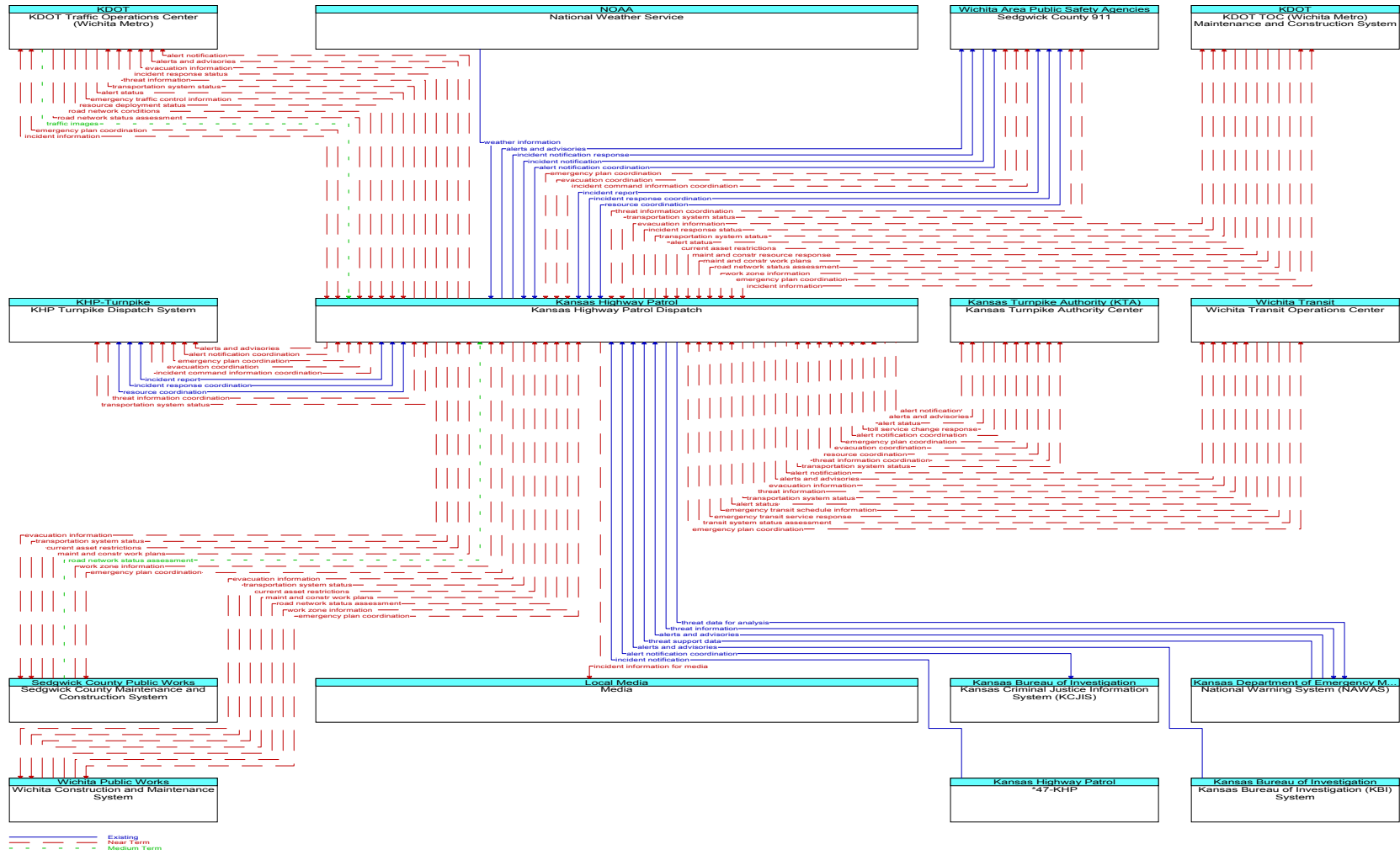


Figure 14. Kansas Highway Patrol Dispatch Communications Diagram (Part 1)

# Wichita Area Regional ITS Architecture – Volume 3

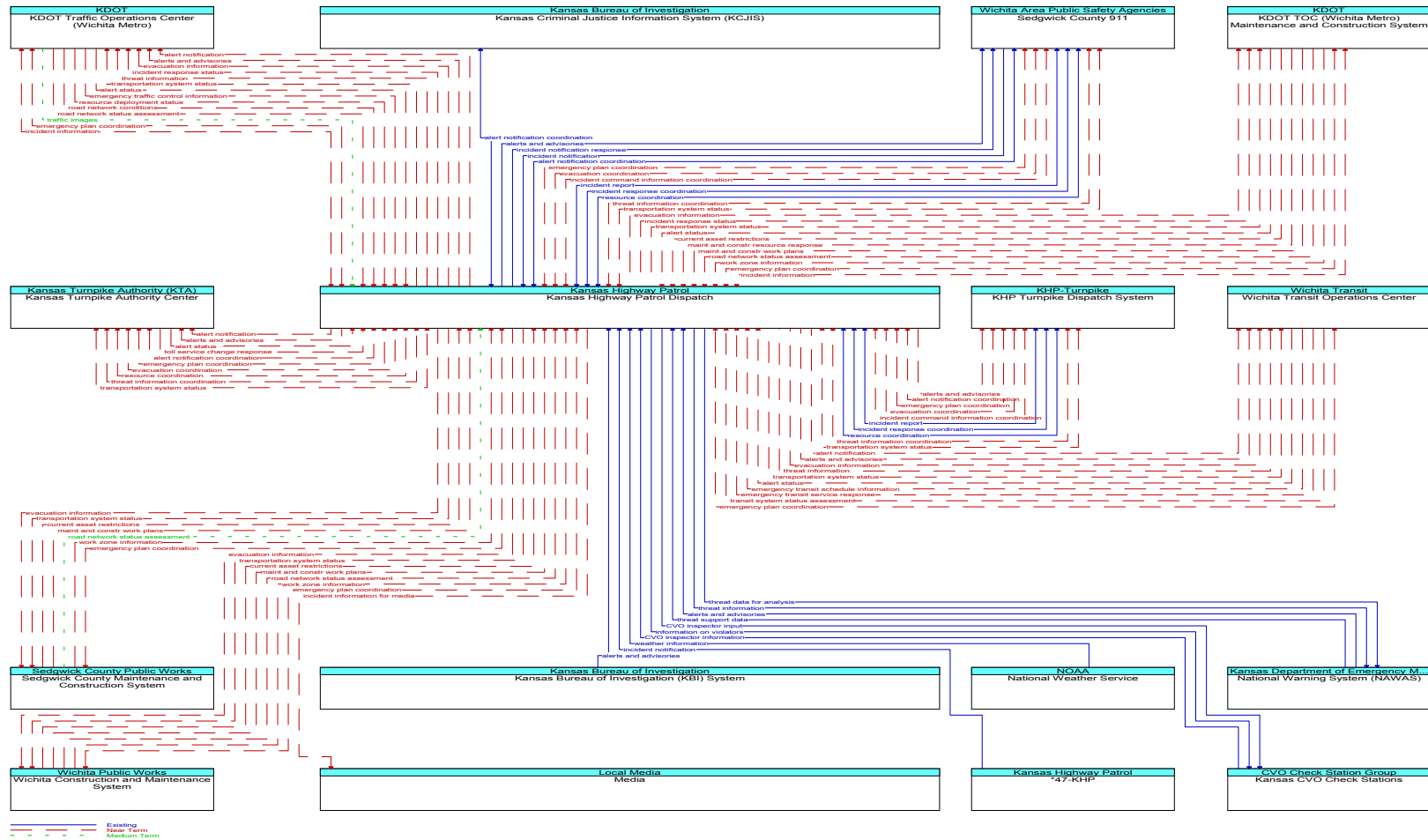
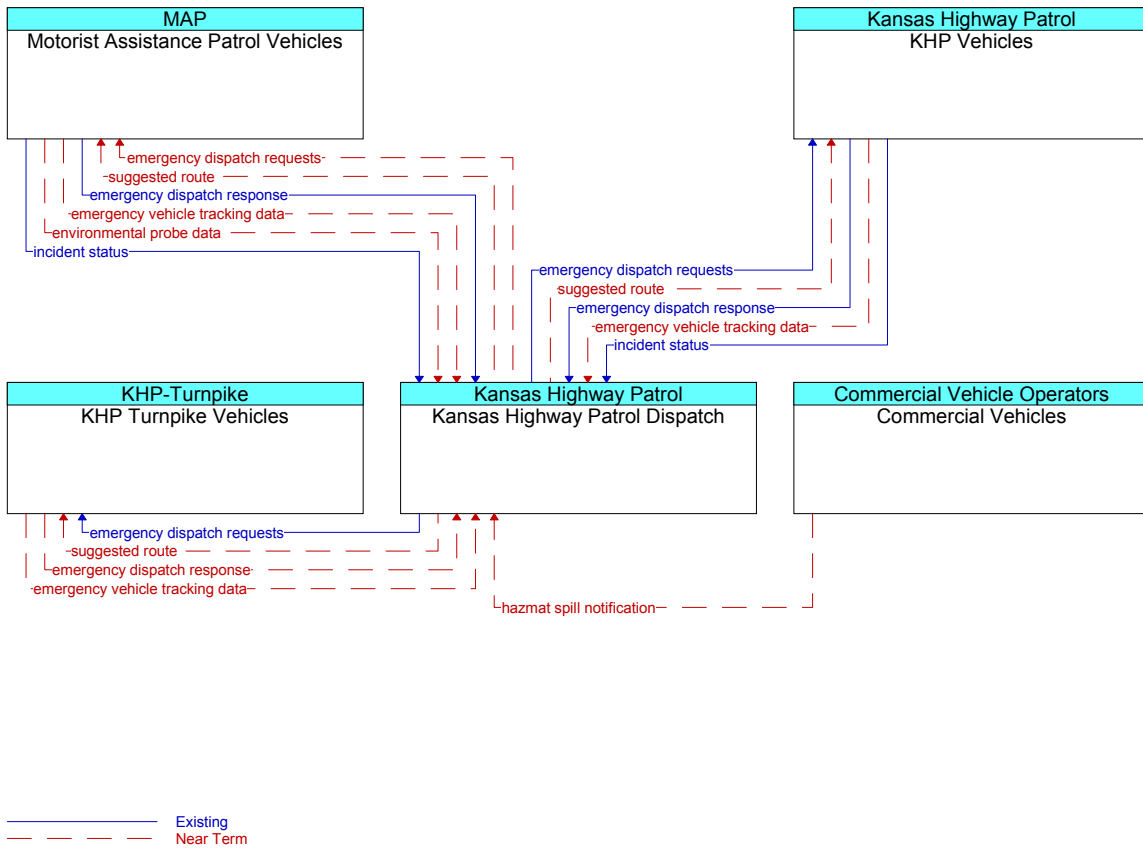


Figure 15. Kansas Highway Patrol Dispatch Communications Diagram (Part 2)



**Figure 16. Kansas Highway Patrol Dispatch Communications Diagram (Part 3)**

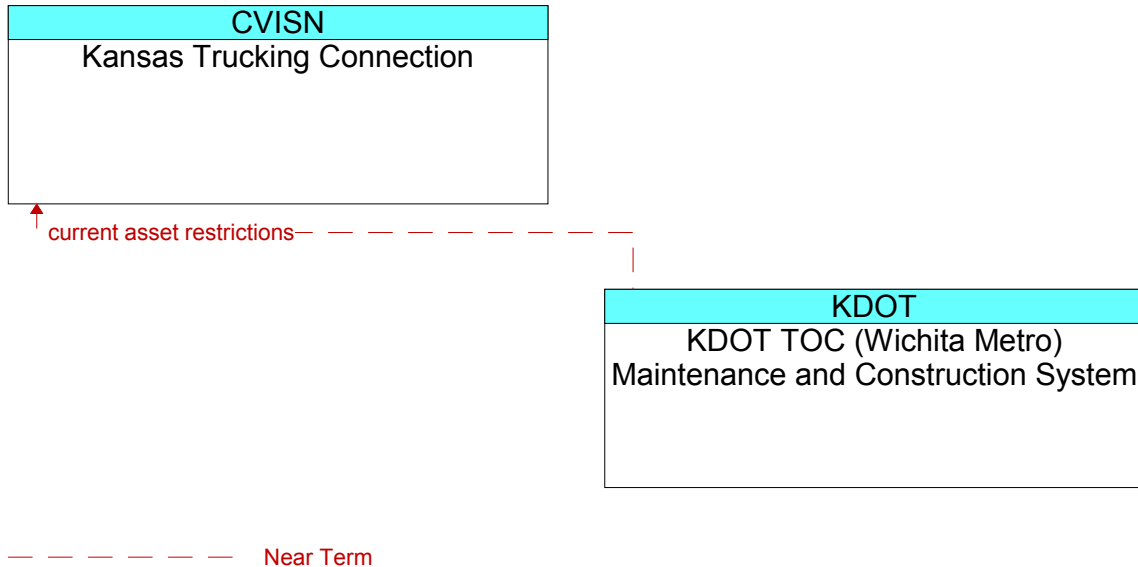
The Kansas Highway Patrol Dispatch has an extensive communication system that communicates with 20 entities in the Wichita metropolitan area. While a decent amount of information flows currently exist an extensive amount need to be added in the near term and a small amount added in the medium term. Currently the Kansas Highway Patrol Dispatch communicates with many public safety agencies, Kansas Criminal Justice Information System and the National Weather Service. In summary, the public safety agencies exchange alerts, coordination, violators, alerts & advisories, emergency dispatch and incident information. The Kansas Criminal Justice Information System currently receives alert notification coordination information from Kansas Highway Patrol Dispatch. The National Weather Service currently sends weather information to the Kansas Highway Patrol Dispatch. The public safety and Kansas Criminal Justice Information System are likely on a dedicated network due to the life safety aspects associated with the data. The information from the National Weather Service is likely a general broadcast message that is available to private and public sectors alike.

There are a plethora of new information flows that need to be deployed in the near and mid term. The information flows are too extensive to list here but there are 10 additional entities that the Kansas Highway Patrol Dispatch will be developing information flows with. Collectively, the 10 existing entities will be extensively expanding the quantity of

information flows to meet the near and mid term needs. It is likely that the communication needs will be met using local leased line services and dedicated networks.

## 2.15 Kansas Trucking Connection

The following diagram (Figure 17) shows all interfaces in the regional ITS architecture surrounding the Kansas Trucking Connection element with annotated timeframes for expected communication content. The associated stakeholders are depicted on the top of each box containing an element.



**Figure 17. Kansas Trucking Connection Communications Diagram**

In the near-term there is a need for the KDOT TOC (Wichita Metro) Maintenance and Construction System to report current asset restrictions to the Kansas Trucking Connection. This is a point-to-point communication interface which could be implemented using local leased line service or a dedicated network.

## 2.16 Kansas Turnpike Authority Center

The following diagram (Figure 18, Figure 19 and Figure 20) shows all interfaces in the regional ITS architecture surrounding the Kansas Turnpike Authority Center element with annotated timeframes for expected communication content. The associated stakeholders are depicted on the top of each box containing an element.

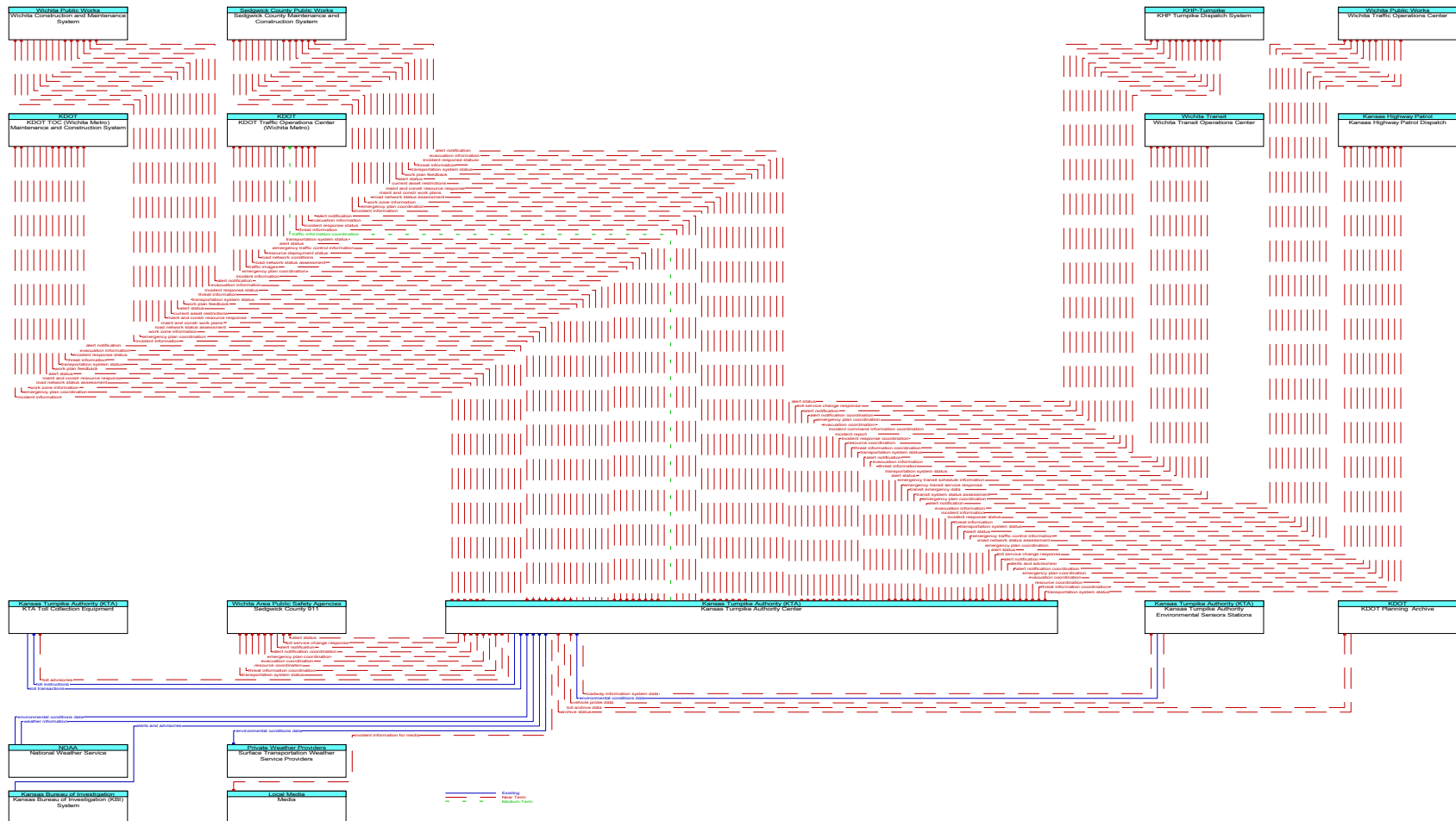
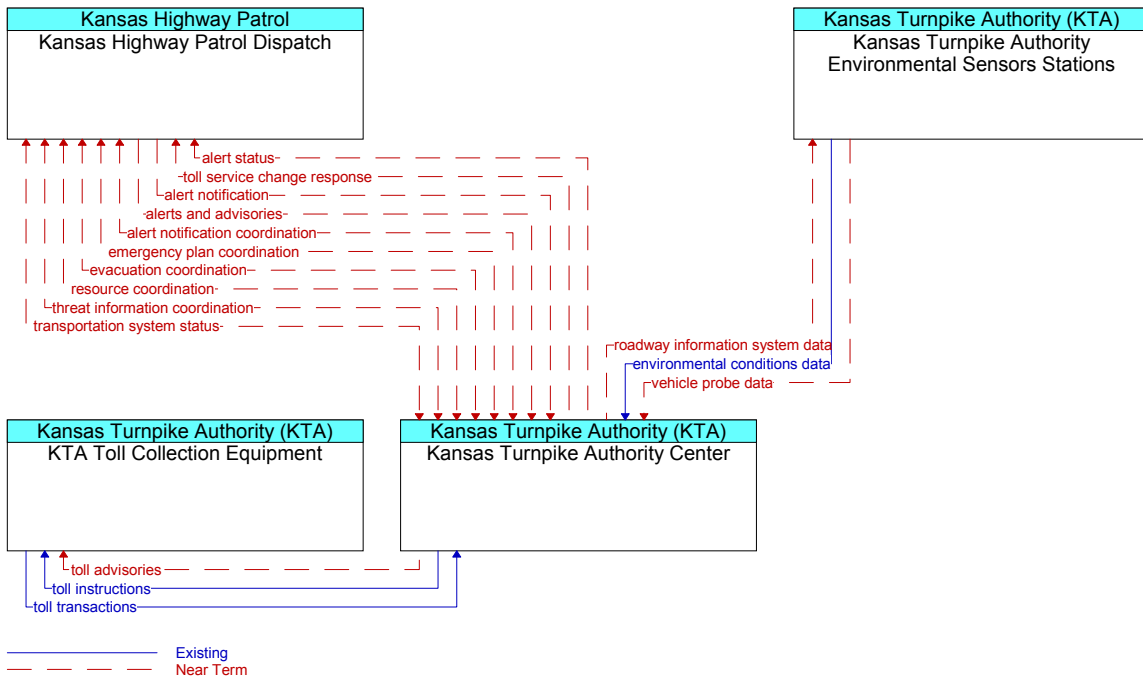
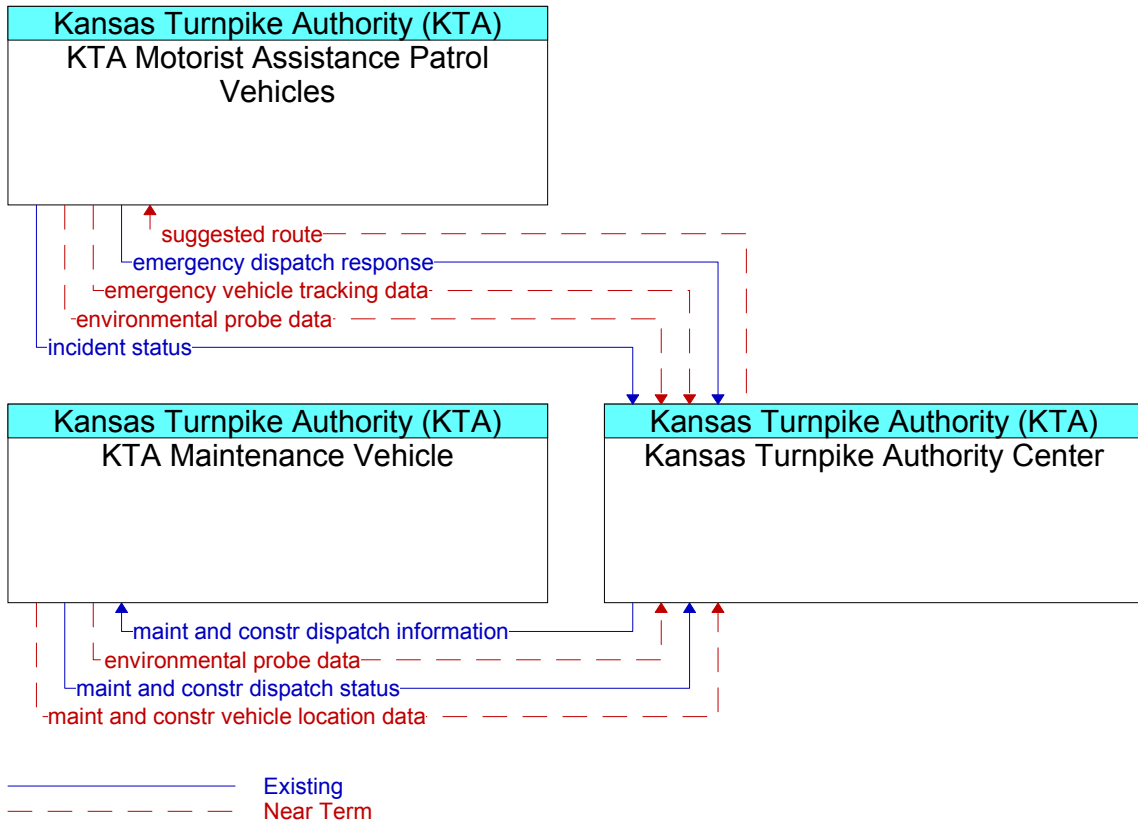


Figure 18. Kansas Turnpike Authority Center Communications Diagram (Part 1)



**Figure 19. Kansas Turnpike Authority Center Communications Diagram (Part 2)**



**Figure 20. Kansas Turnpike Authority Center Communications Diagram (Part 3)**

The Kansas Turnpike Authority Center has an extensive communication system that communicates with 19 entities in the Wichita metropolitan area. While several information flows currently exist, a plethora of information flows need to be added in the near term and one information flow added in the medium term. Currently the Kansas Turnpike Authority Center communicates with KTA Motorist Assistance Patrol Vehicles, KTA Maintenance Vehicles, KTA Toll Collection Equipment, Surface Transportation Weather Service Providers, Kansas Bureau of Investigation (KBI) System and the National Weather Service. In summary, the KTA entities exchange incident, dispatch and toll information. The Kansas Bureau of Investigation (KBI) System currently provides alerts and advisories to the Kansas Turnpike Authority Center. The Surface Transportation Weather Service Providers currently receive environmental conditions data from the Kansas Turnpike Authority Center.

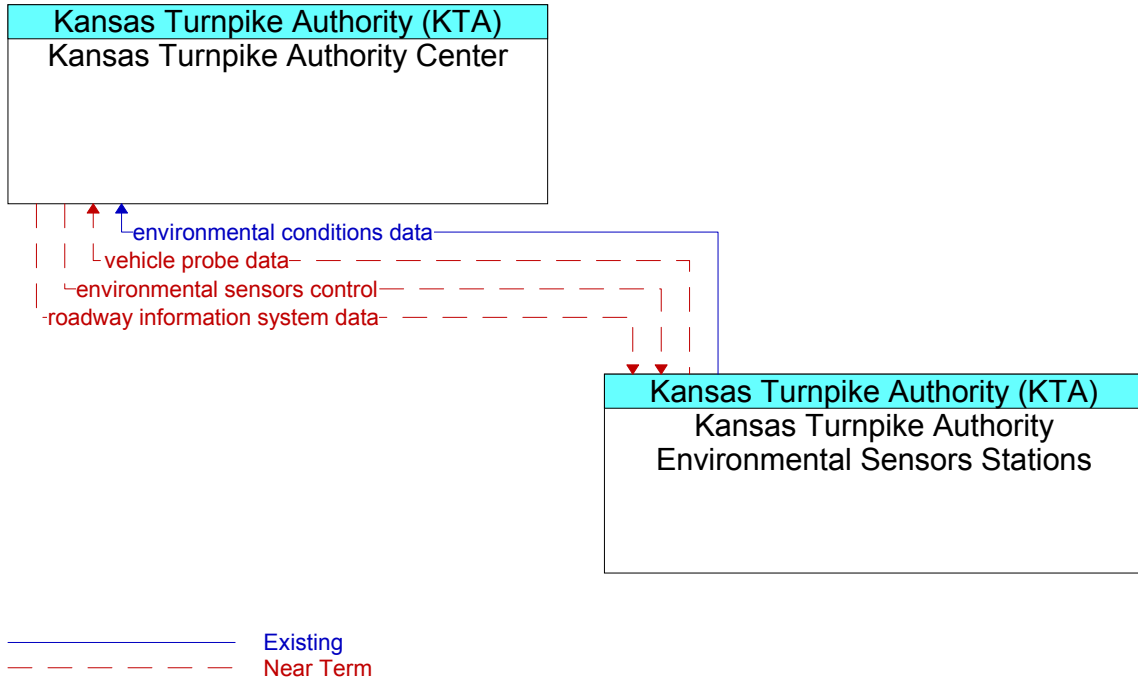
The KTA Motorist Assistance Patrol Vehicles and KTA Maintenance Vehicles are on a wireless network. The KTA Toll Collection Equipment is likely on a dedicated private network since it addresses financial transactions. The information from the National Weather Service is likely a general broadcast message that is available to private and public sectors alike.

There are a plethora of new information flows that need to be deployed in the near and mid term. The information flows are too extensive to list here but there are 12 additional entities that the Kansas Turnpike Authority Center will be developing information flows

with. It is likely that the communication needs will be met using local leased line services and dedicated networks.

## 2.17 Kansas Turnpike Authority Environmental Sensors Stations

The following diagram (Figure 21) shows all interfaces in the regional ITS architecture surrounding the Kansas Turnpike Authority Environmental Sensor Stations element with annotated timeframes for expected communication content. The associated stakeholders are depicted on the top of each box containing an element.



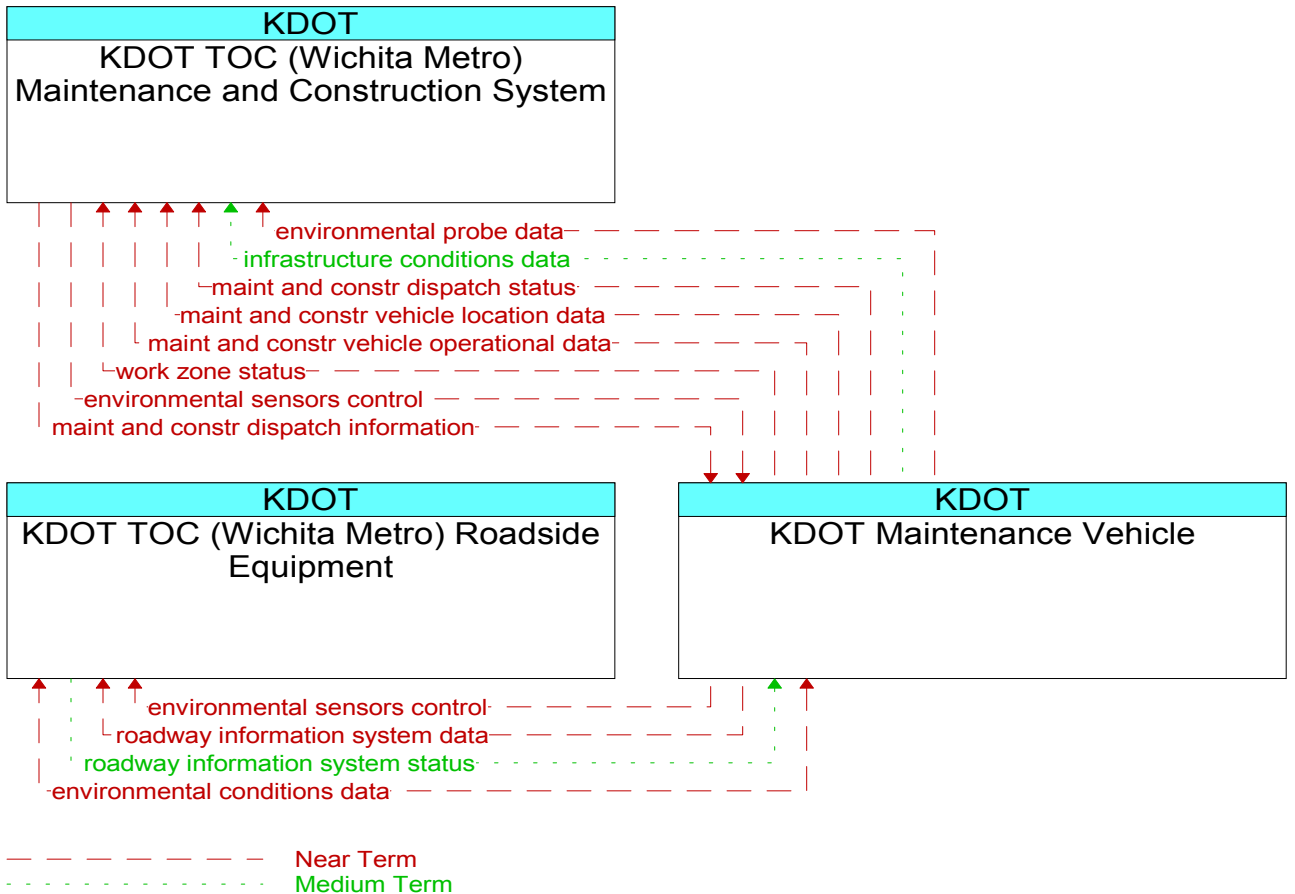
**Figure 21. Kansas Turnpike Authority Environmental Sensor Stations Diagram**

The Kansas Turnpike Authority Environmental Sensor Stations currently communicate with Kansas Turnpike Authority Center to send environmental conditions data to the Kansas Turnpike Authority Center. In the near-term there is a need for the Kansas Turnpike Authority Center to send roadway information system data to the Turnpike Authority Environmental Sensor Stations. In the near-term there is also a need for the Kansas Turnpike Authority Center to receive vehicle probe data from the Turnpike Authority Environmental Sensor Stations. The Kansas Turnpike Authority Environmental Sensor Stations currently communicate with the Kansas Turnpike Authority Center using a dedicated network to send environmental conditions data to the Kansas Turnpike Authority Center. It is likely that the same communication infrastructure will be used to transport the new data introduced by the near term information flows that will be added.



## 2.18 KDOT Maintenance Vehicle

The following diagram (Figure 22) shows all interfaces in the regional ITS architecture surrounding the KDOT Maintenance Vehicle element with annotated timeframes for expected communication content. The associated stakeholders are depicted on the top of each box containing an element.



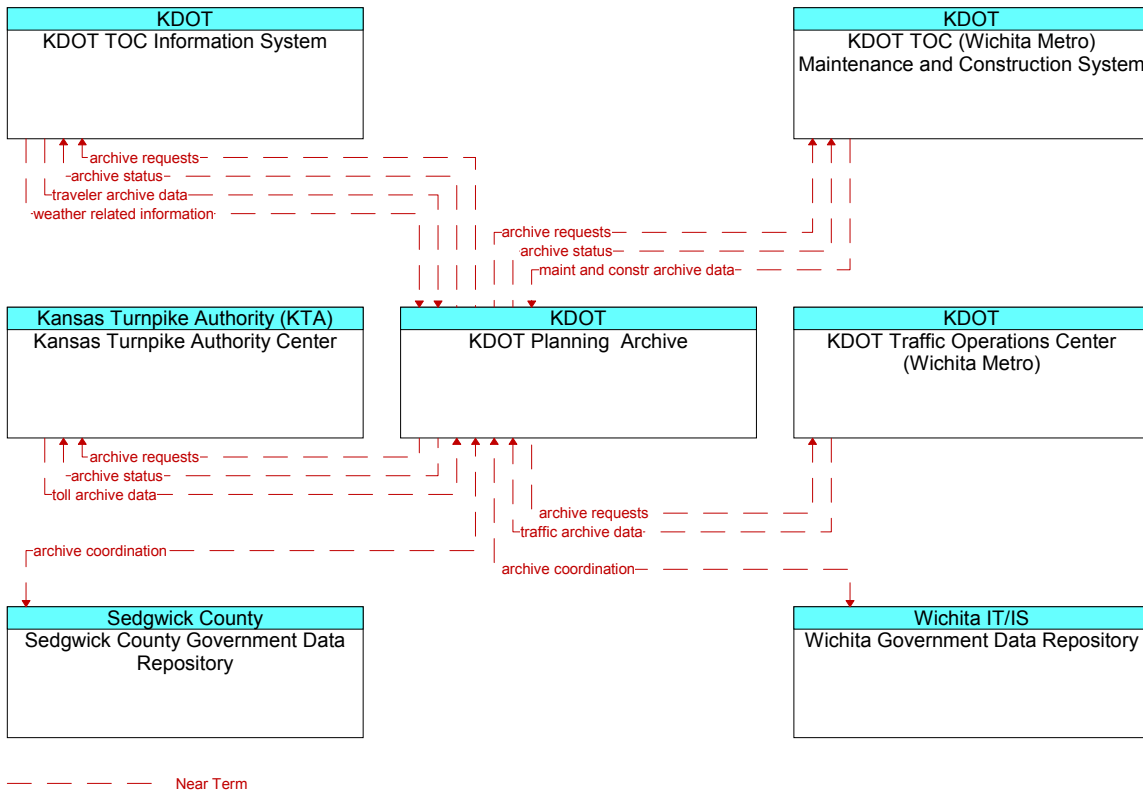
**Figure 22. KDOT Maintenance Vehicle Communications Diagram**

In the near-term and medium-term, there is a need for the roadside equipment to exchange information with the KDOT Maintenance Vehicles. In the near-term and medium-term, there is also a need for the KDOT Maintenance Vehicles to exchange information with the KDOT TOC (Wichita Metro) Maintenance and Construction System. These near and medium-term needs will require that a wireless communication network be deployed to address these new information flows. It's likely that a dedicated network will be deployed to address these needs.

## 2.19 KDOT Planning Archive

The following diagram (Figure 23) shows all interfaces in the regional ITS architecture surrounding the KDOT Planning Archive element with annotated timeframes for

expected communication content. The associated stakeholders are depicted on the top of each box containing an element.

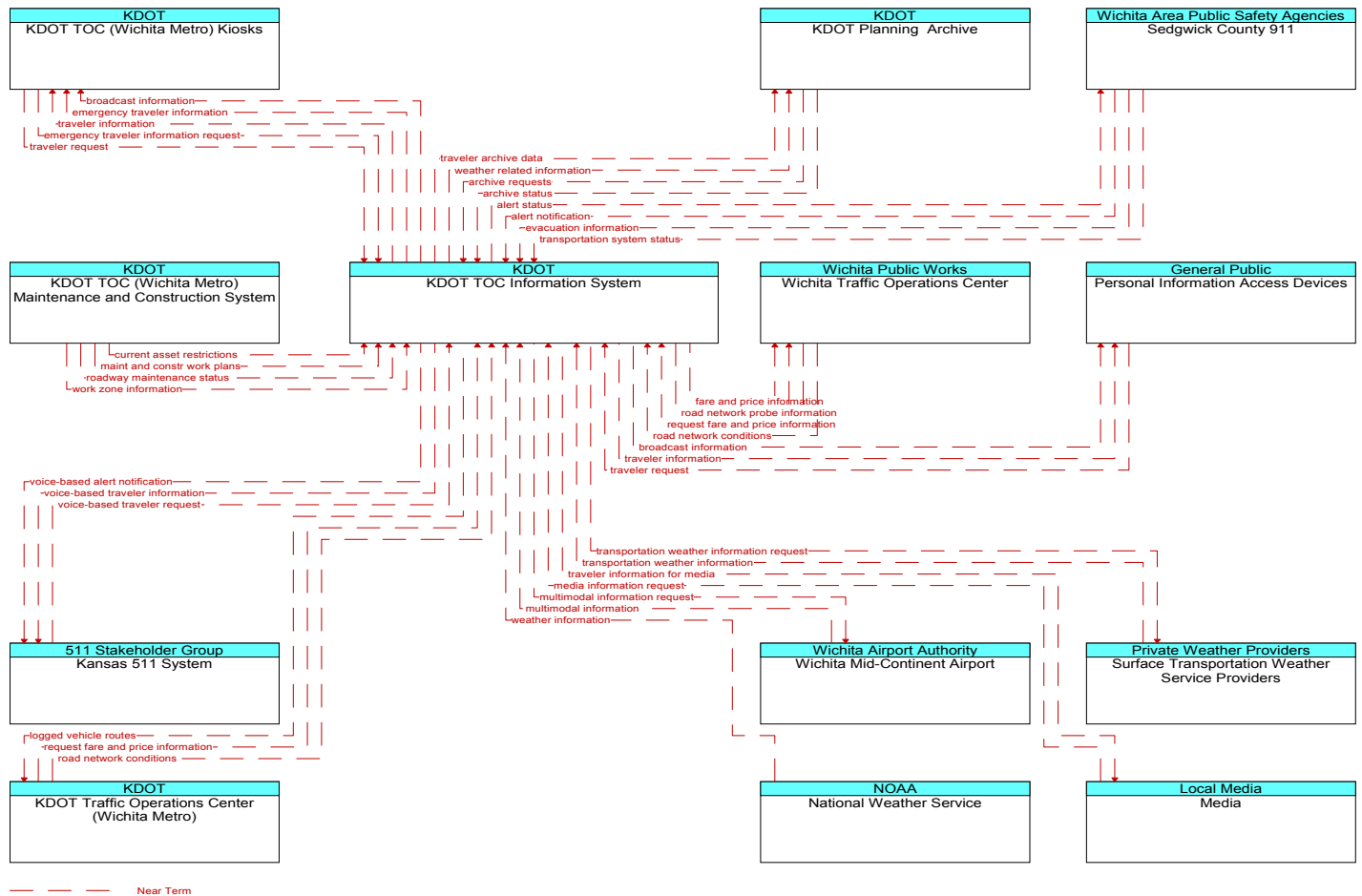


**Figure 23. KDOT Planning Archive Communications Diagram**

In the near term it is required that the KDOT Planning Archive exchange information with other agencies in the area. These are all centers which lend themselves to point to point connectivity. Since it is mostly archive data and is not required on a real-time basis it is likely that these agencies will be interconnected via leased line services unless existing dedicated networks are already available.

## 2.20 KDOT TOC Information System

The following diagram (Figure 24) shows all interfaces in the regional ITS architecture surrounding the KDOT TOC Information System element with annotated timeframes for expected communication content. The associated stakeholders are depicted on the top of each box containing an element.

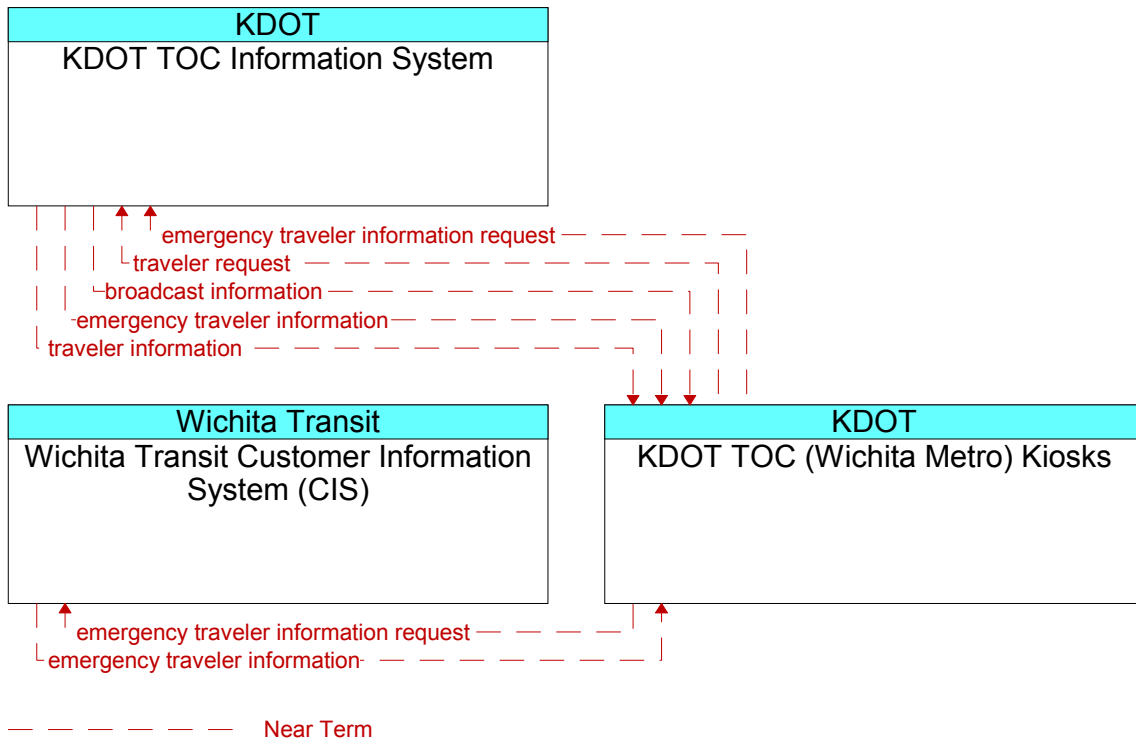


**Figure 24. KDOT TOC Information System Communications Diagram**

In the near-term the KDOT TOC Information System will need to establish communication with several KDOT and outside agencies. It’s likely that KDOT will expand their communication infrastructure to address their internal communication needs and that leased lines will be established with the outside agencies.

## 2.21 KDOT TOC (Wichita Metro) Kiosks

The following diagram (Figure 25) shows all interfaces in the regional ITS architecture surrounding the KDOT TOC (Wichita Metro) Kiosks element with annotated timeframes for expected communication content. The associated stakeholders are depicted on the top of each box containing an element.

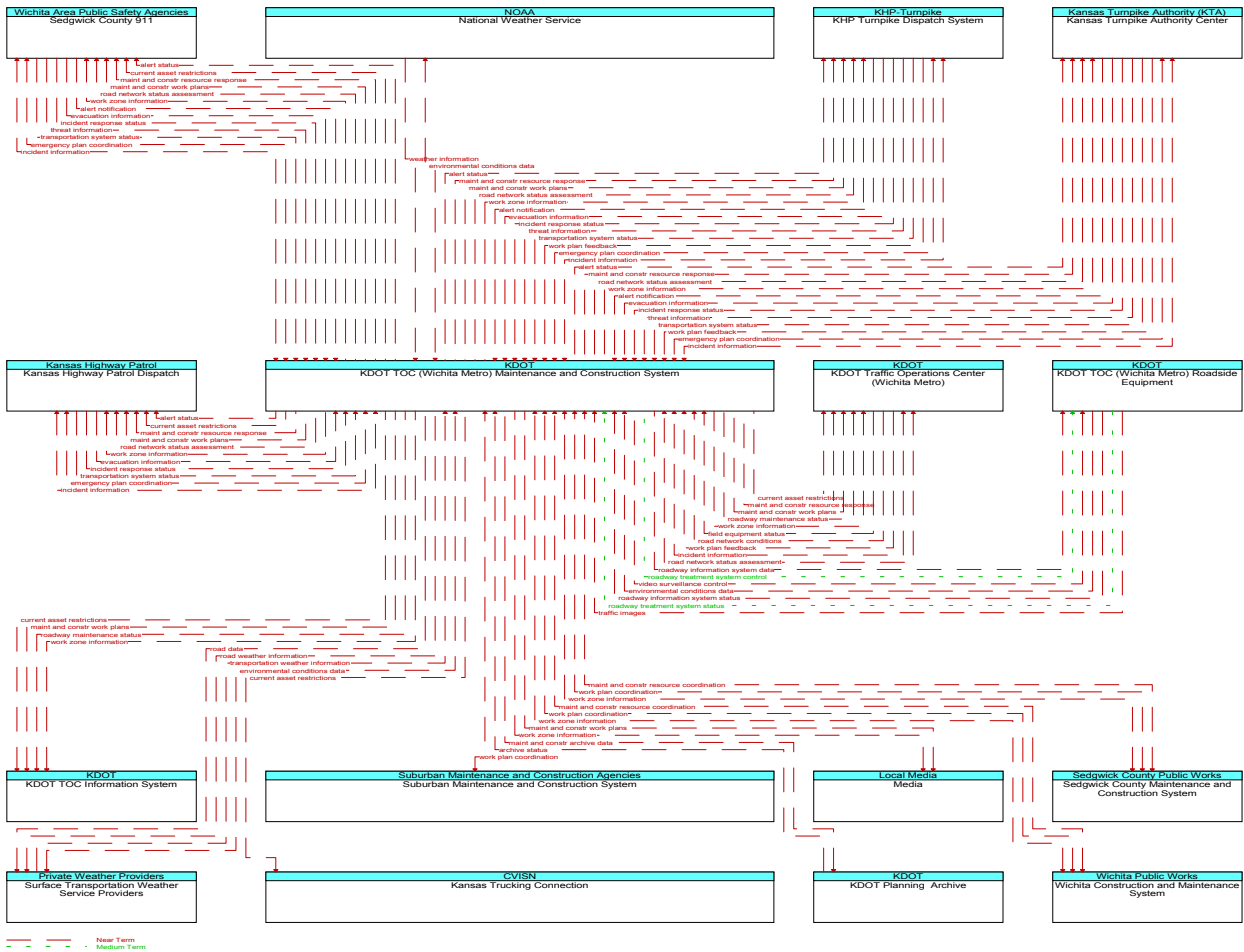


**Figure 25. KDOT TOC (Wichita Metro) Kiosks Communications Diagram**

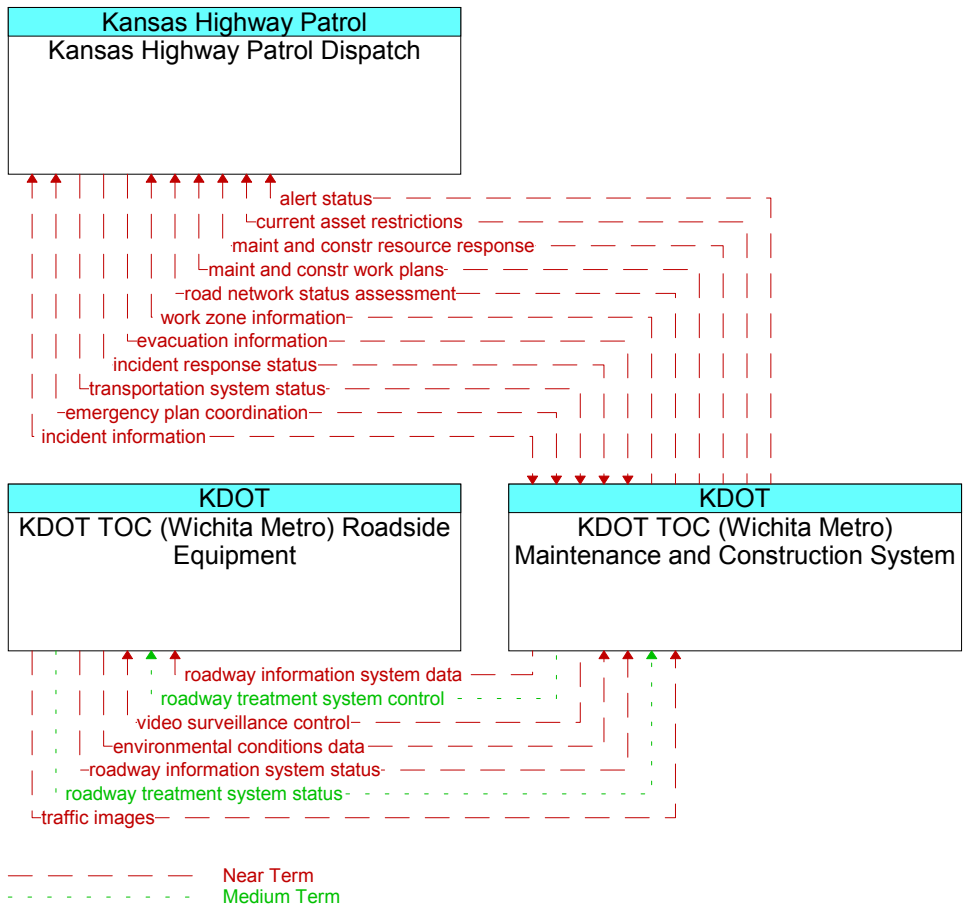
In the near-term the KDOT TOC (Wichita Metro) Kiosks will need to establish communication with the KDOT TOC Information System and the Wichita Transit Customer Information System (CIS). It’s likely that KDOT will expand their communication infrastructure to address their internal communication needs and that leased lines will be established between the Wichita Transit Customer Information System (CIS) and the KDOT TOC (Wichita Metro) Kiosks.

## 2.22 KDOT TOC (Wichita Metro) Maintenance and Construction System

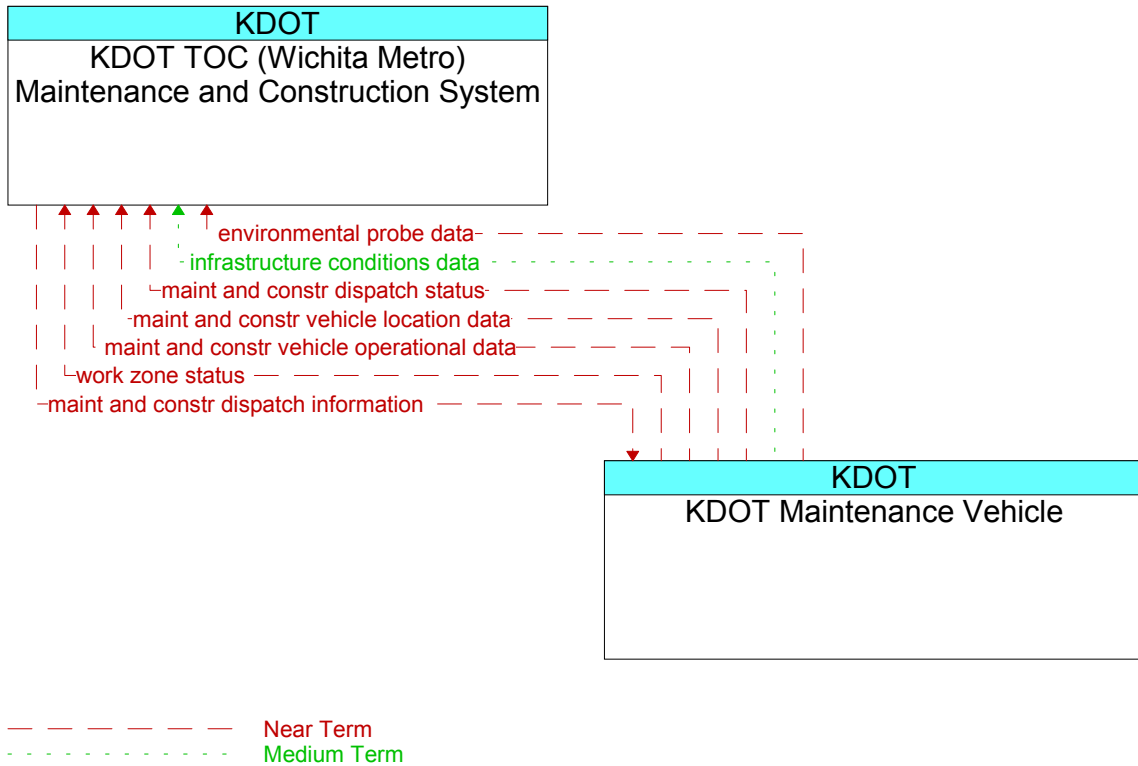
The following diagram (Figure 26, Figure 27 and Figure 28) shows all interfaces in the regional ITS architecture surrounding the KDOT TOC (Wichita Metro) Maintenance and Construction System element. The associated stakeholders are depicted on the top of each box containing an element.



**Figure 26. KDOT TOC (Wichita Metro) Maintenance and Construction System Communications Diagram (Part 1)**



**Figure 27. KDOT TOC (Wichita Metro) Maintenance and Construction System Communications Diagram (Part 2)**

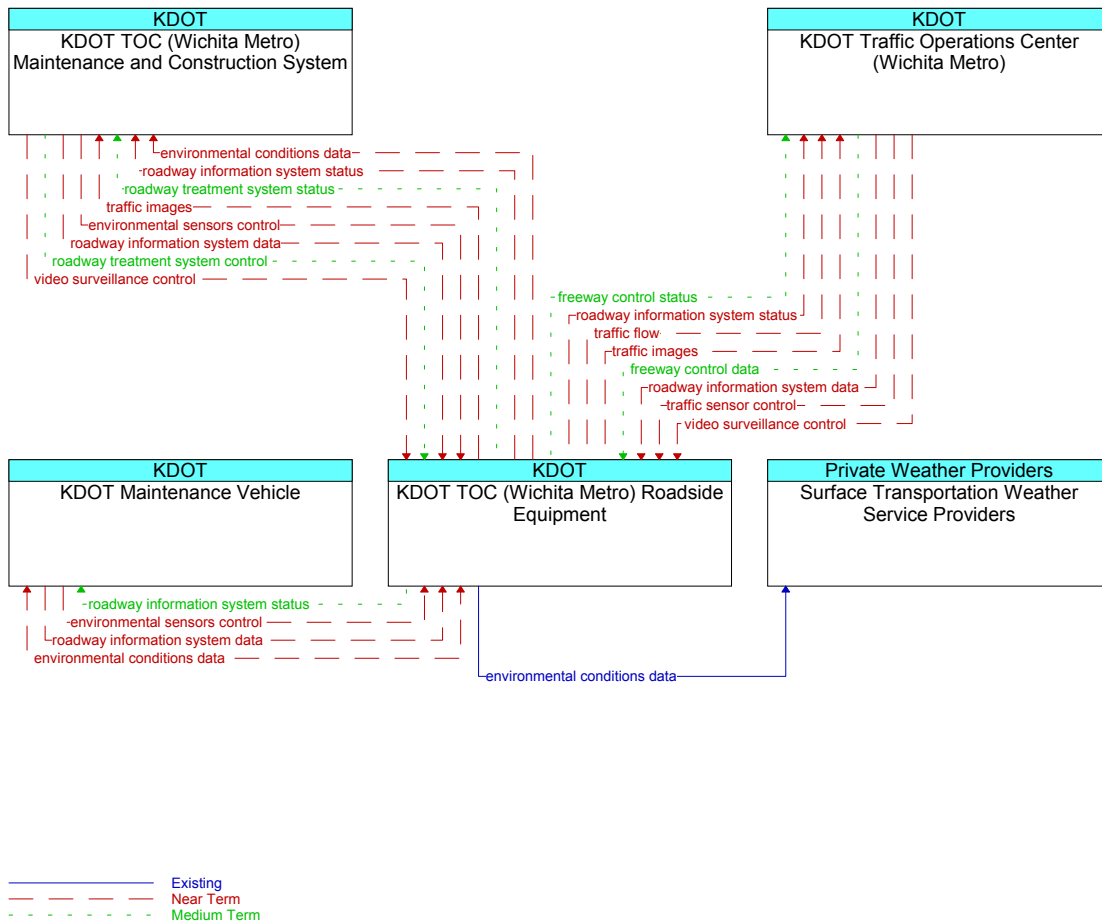


**Figure 28. KDOT TOC (Wichita Metro) Maintenance and Construction System Communications Diagram (Part 3)**

In the near and medium-term the KDOT TOC (Wichita Metro) Maintenance and Construction System will need to establish communication with 16 agencies to exchange a plethora of data contained within the information flows shown in the respective figure. Most of the agencies are public sector with the exception of the Media and Surface Transportation Weather Service Providers. It is likely that KDOT TOC (Wichita Metro) Maintenance and Construction System will expand their communication infrastructure to address their internal communication needs and that leased lines will be established between the KDOT TOC (Wichita Metro) Maintenance and Construction System and the other agencies.

### 2.23 KDOT TOC (Wichita Metro) Roadside Equipment

The following diagram (Figure 29) shows all interfaces in the regional ITS architecture surrounding the KDOT TOC (Wichita Metro) Roadside Equipment element with annotated timeframes for expected communication content. The associated stakeholders are depicted on the top of each box containing an element.



**Figure 29. KDOT TOC (Wichita Metro) Roadside Equipment Communications Diagram**

KDOT TOC (Wichita Metro) Roadside Equipment currently has existing communication with Surface Transportation Weather Service Providers to transmit environmental conditions data to the Transportation Weather Service Providers. In the near and medium-term KDOT TOC (Wichita Metro) Roadside Equipment will need to establish communications to 3 other KDOT entities. It is likely that KDOT will expand their existing communication infrastructure to meet the point to point and mobile communication needs and leased lines will be established to other agencies.

## 2.24 KDOT Traffic Operations Center (Wichita Metro)

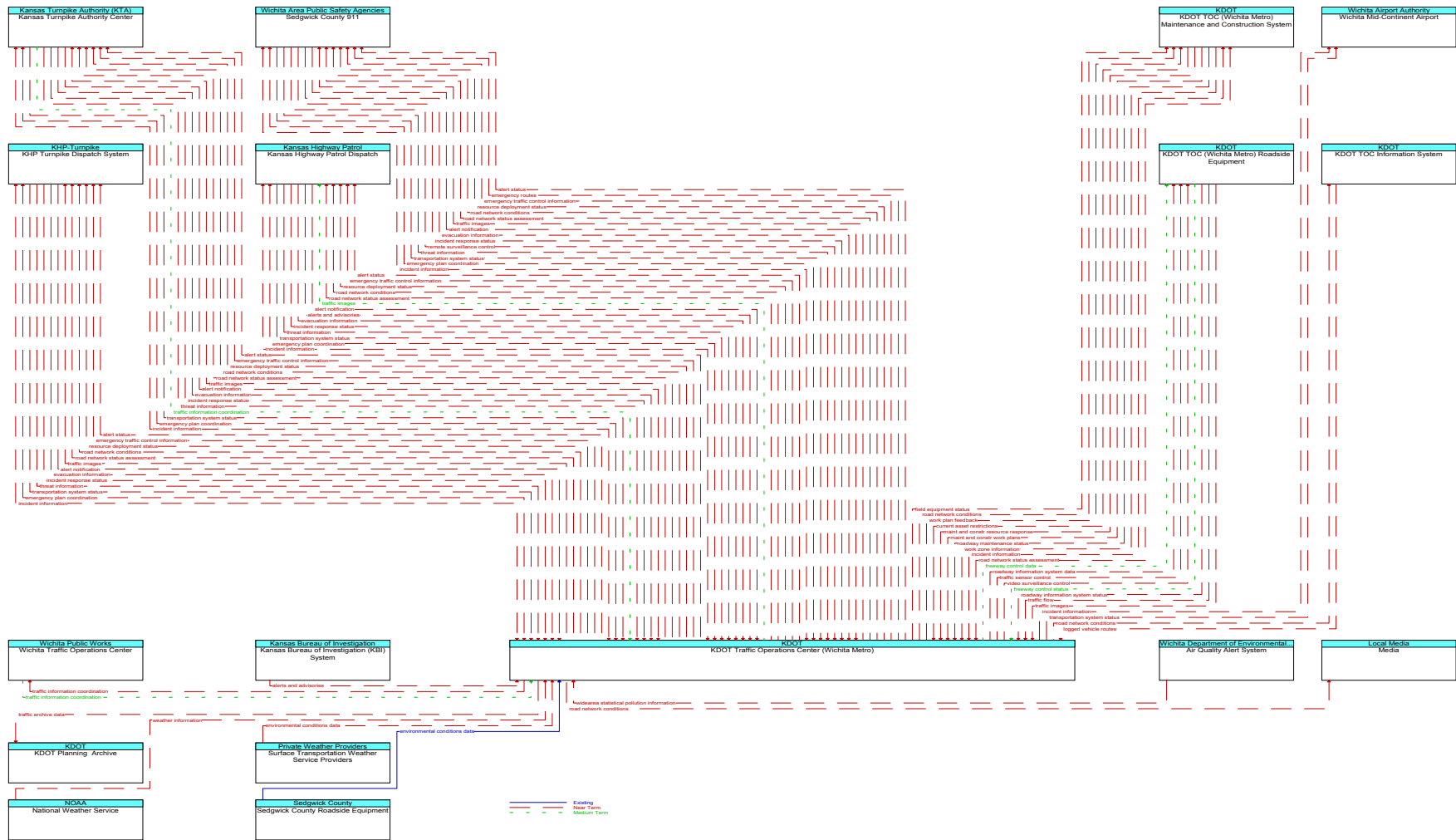
The following diagram (Figure 30, Figure 31 and Figure 32) shows all interfaces in the regional ITS architecture surrounding the KDOT Traffic Operations Center (Wichita Metro) element with annotated timeframes for expected communication content. The associated stakeholders are depicted on the top of each box containing an element.

KDOT Traffic Operations Center (Wichita Metro) currently only has 2 existing information flows established to other agencies. In the near and medium-term KDOT Traffic Operations Center (Wichita Metro) will need to establish communications with many other outside agencies and to several KDOT entities. It is likely that KDOT will

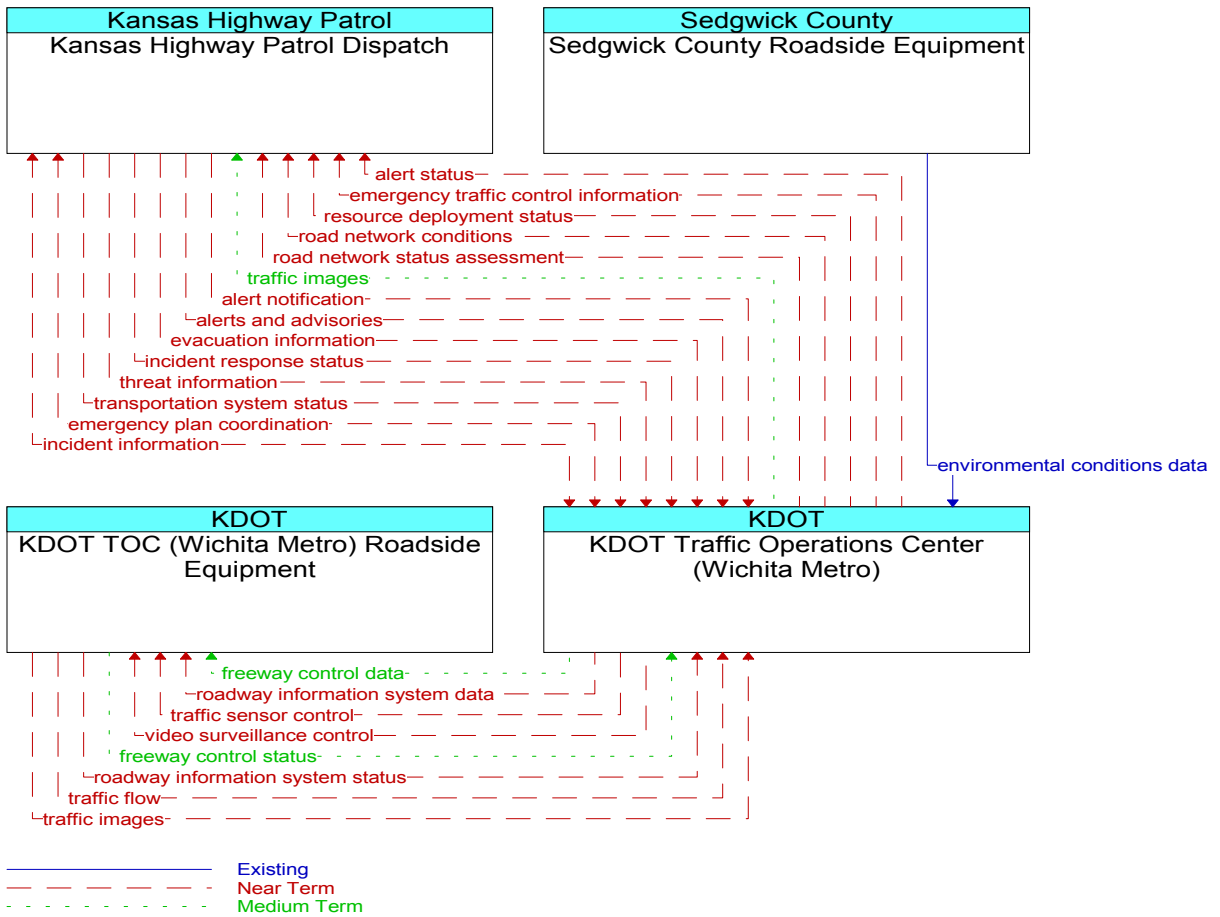


expand their existing communication infrastructure to meet their communication needs and leased lines will be established to other agencies.

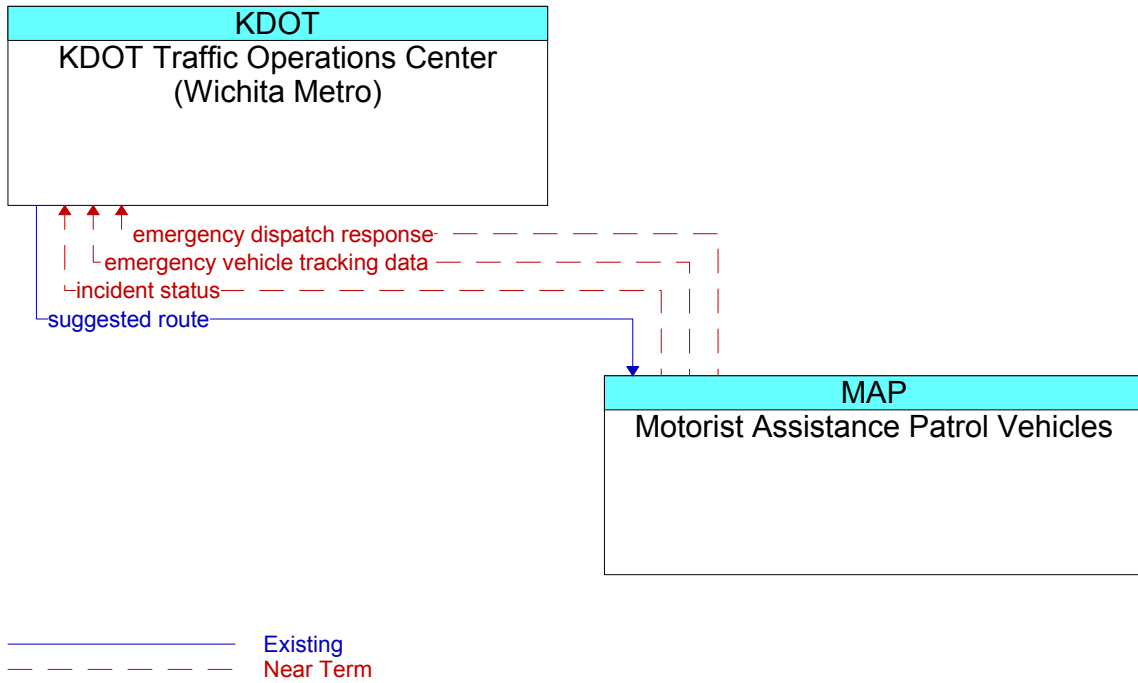
# Wichita Area Regional ITS Architecture – Volume 3



**Figure 30. KDOT Traffic Operations Center (Wichita Metro) Communications Diagram (Part 1)**



**Figure 31. KDOT Traffic Operations Center (Wichita Metro) Communications Diagram (Part 2)**



**Figure 32. KDOT Traffic Operations Center (Wichita Metro) Communications Diagram (Part 3)**

## 2.25 KHP Turnpike Dispatch System

The following diagram (Figure 33, Figure 34 and Figure 35) shows all interfaces in the regional ITS architecture surrounding the KHP Turnpike Dispatch System element with annotated timeframes for expected communication content. The associated stakeholders are depicted on the top of each box containing an element.

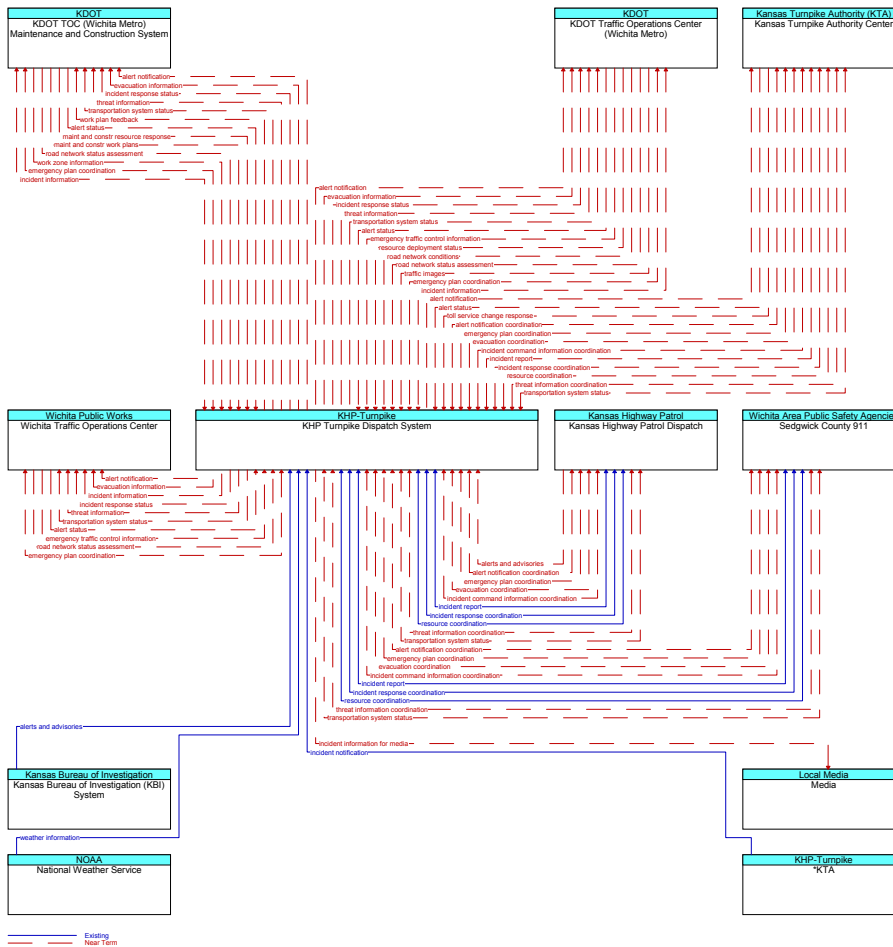


Figure 33. KHP Turnpike Dispatch System Communications Diagram (Part 1)

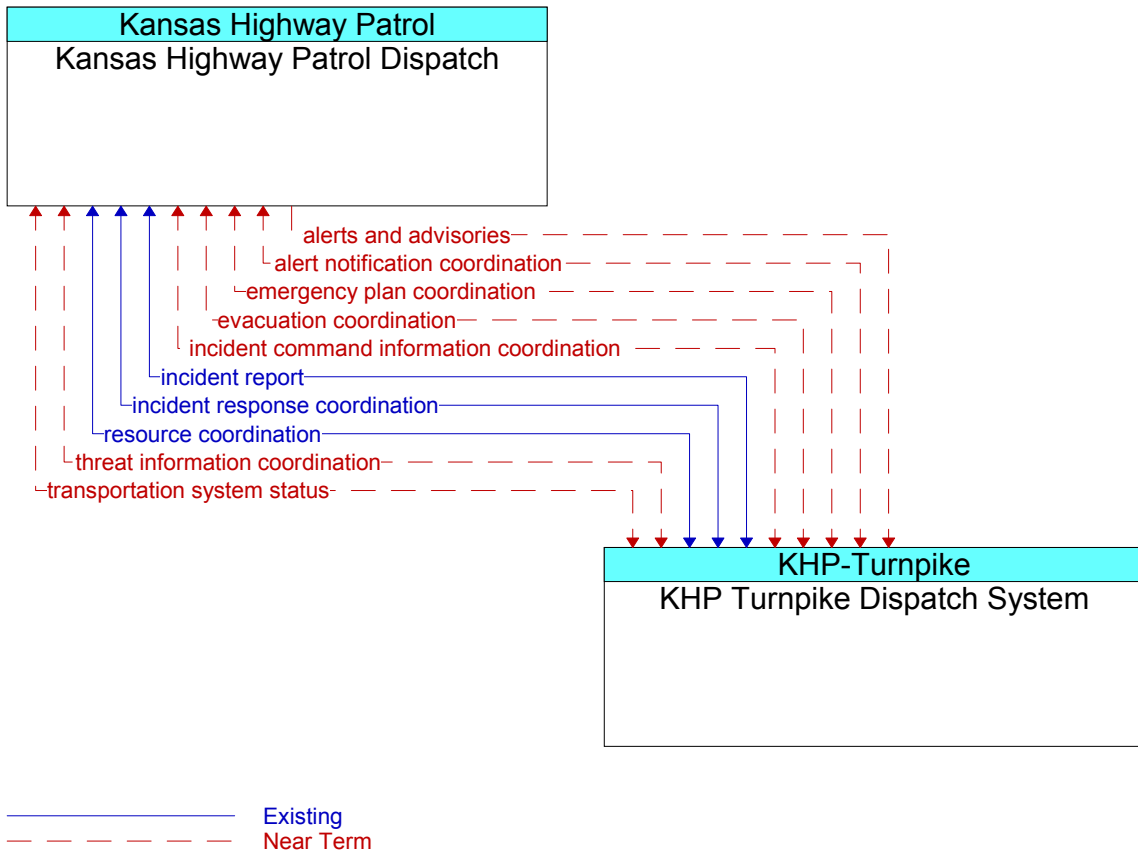
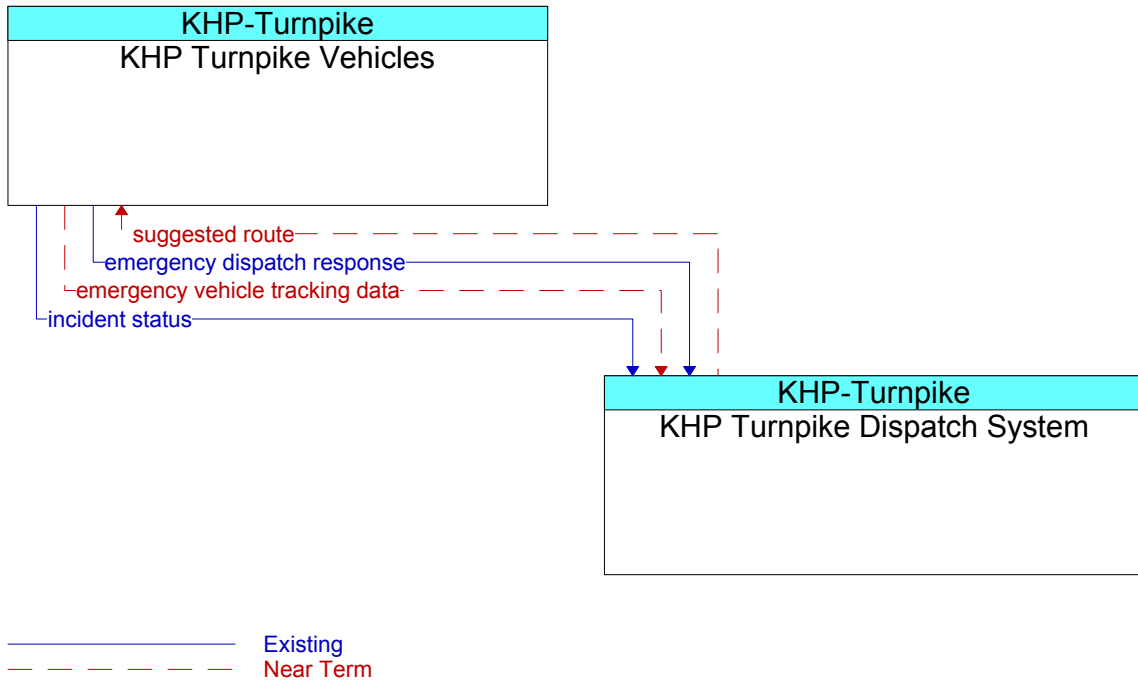


Figure 34. KHP Turnpike Dispatch System Communications Diagram (Part 2)

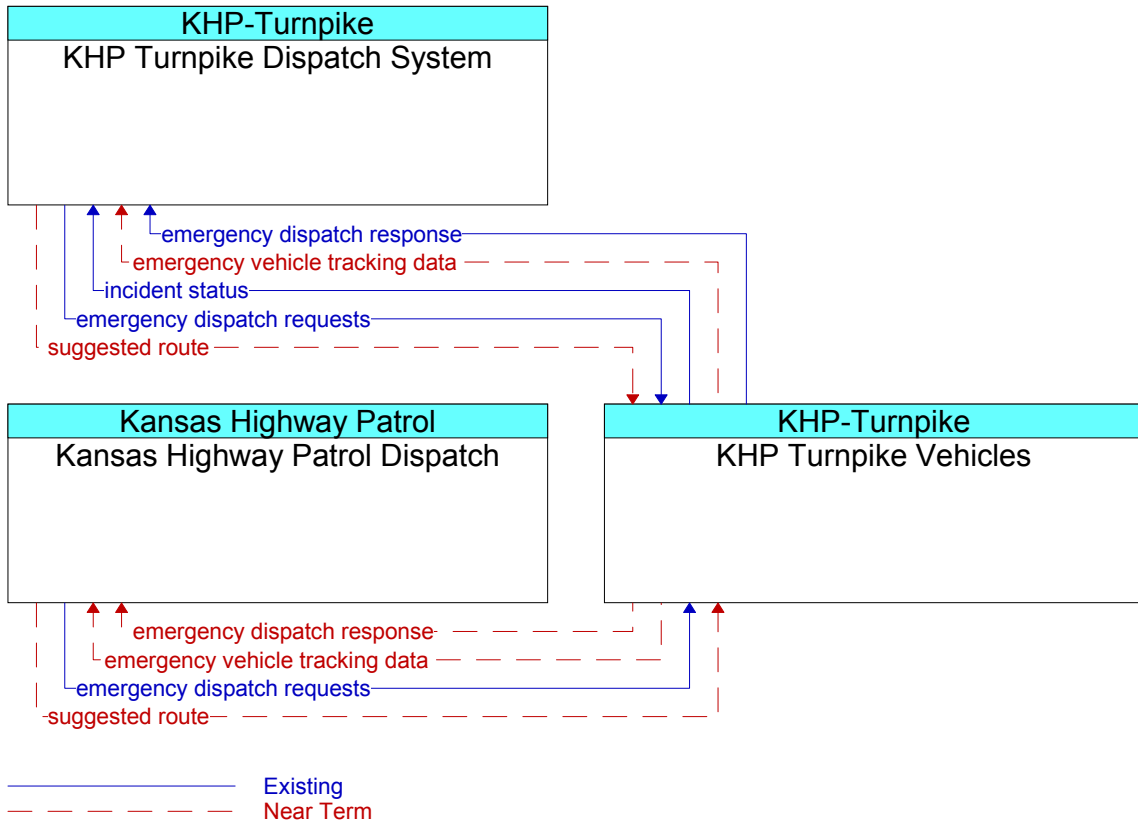


**Figure 35. KHP Turnpike Dispatch System Communications Diagram (Part 3)**

KHP Turnpike Dispatch System currently only has several existing information flows established to other agencies. In the near and medium-term KHP Turnpike Dispatch System will need to establish communications with several other outside agencies and to several KHP entities. It is likely that KHP will expand their existing communication infrastructure to meet their mobile and fixed communication needs and leased lines will likely be established to other agencies.

## 2.26 KHP Turnpike Vehicles

The following diagram (Figure 36) shows all interfaces in the regional ITS architecture surrounding the KHP Turnpike Vehicles element with annotated timeframes for expected communication content. The associated stakeholders are depicted on the top of each box containing an element.



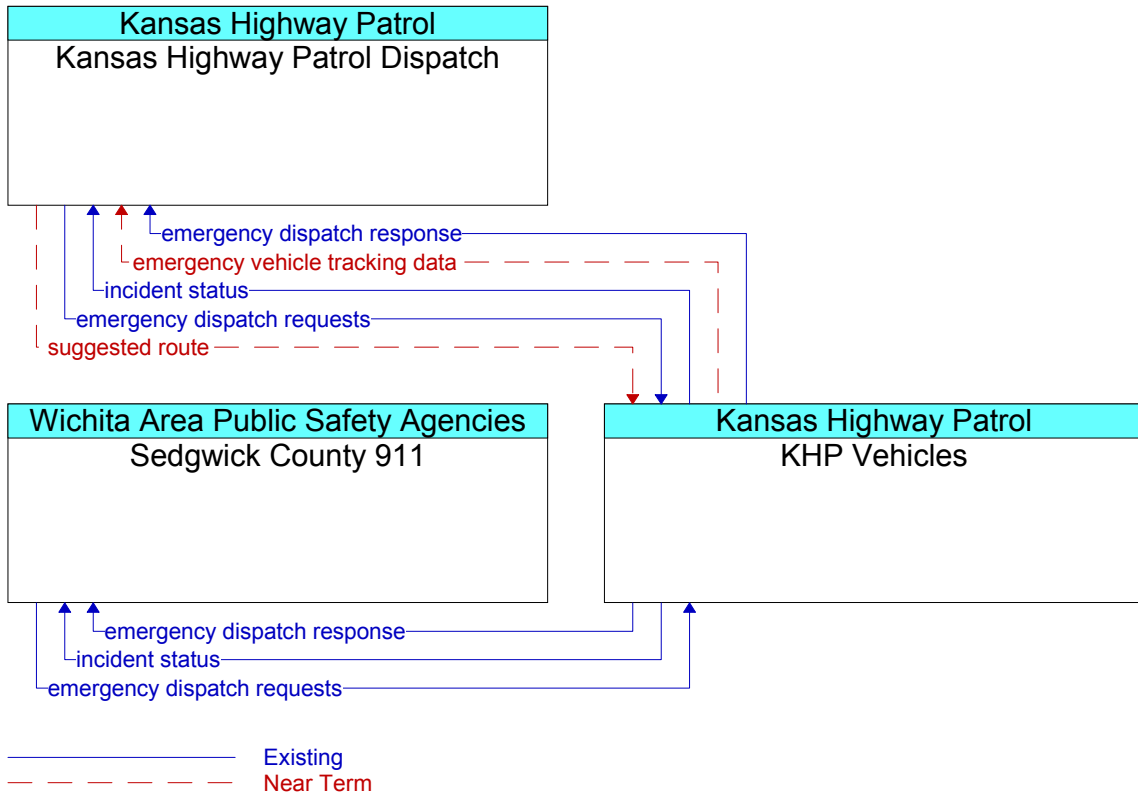
**Figure 36. KHP Turnpike Vehicles Communications Diagram**

KHP Turnpike vehicles currently have 2 existing information flows established to the KHP Turnpike Dispatch System. In the near-term KHP Turnpike Vehicles will need to establish communications with KHP Dispatch and Sedgwick County 911. It is likely that KHP and Sedgwick County 911 will expand their existing communication infrastructure to meet their near term communication needs.

## 2.27 KHP Vehicles

The following diagram (Figure 37) shows all interfaces in the regional ITS architecture surrounding the KHP Vehicles element with annotated timeframes for expected communication content. The associated stakeholders are depicted on the top of each box containing an element.



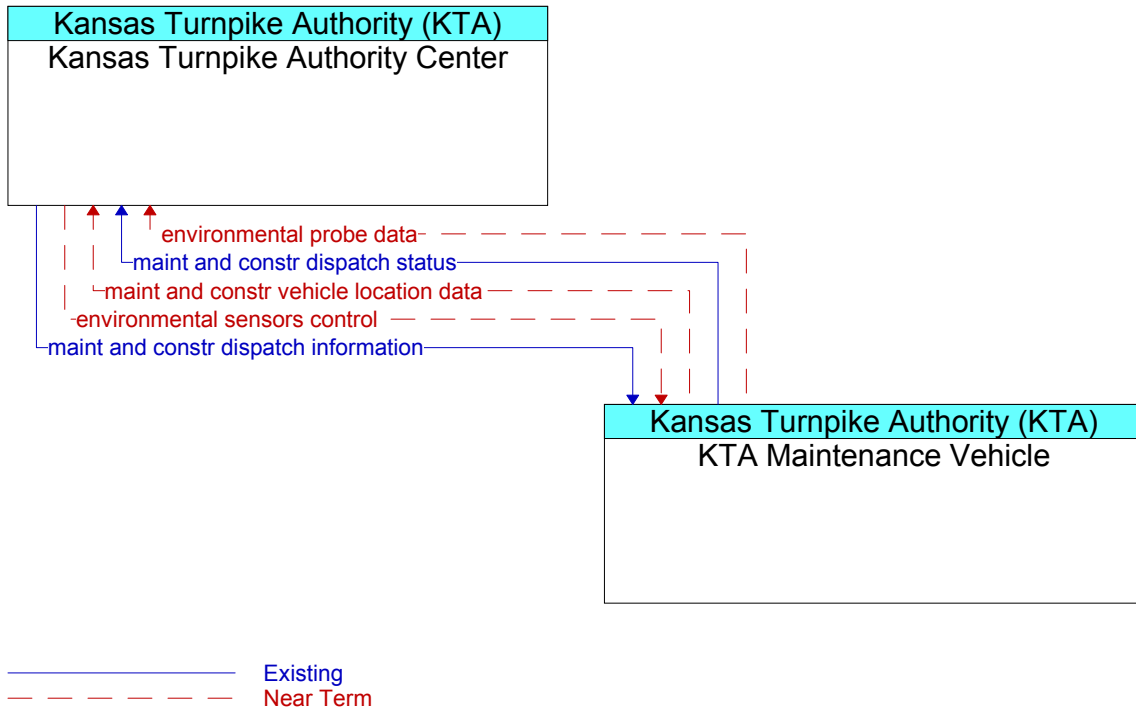


**Figure 37. KHP Vehicles Communications Diagram**

The communications received from the \*47 call-in number from the traveling public to the Kansas Highway Patrol Dispatch contains incident information. A phone connection is currently used for communication. In the near-term there is a need for the KHP Vehicles to send emergency vehicle tracking data to the KHP Dispatch. In the near-term there is also a need for the KHP Dispatch to send suggested route data to the KHP Vehicles.

## 2.28 KTA Maintenance Vehicle

The following diagram (Figure 38) shows all interfaces in the regional ITS architecture surrounding the KTA Maintenance Vehicle element with annotated timeframes for expected communication content. The associated stakeholders are depicted on the top of each box containing an element.

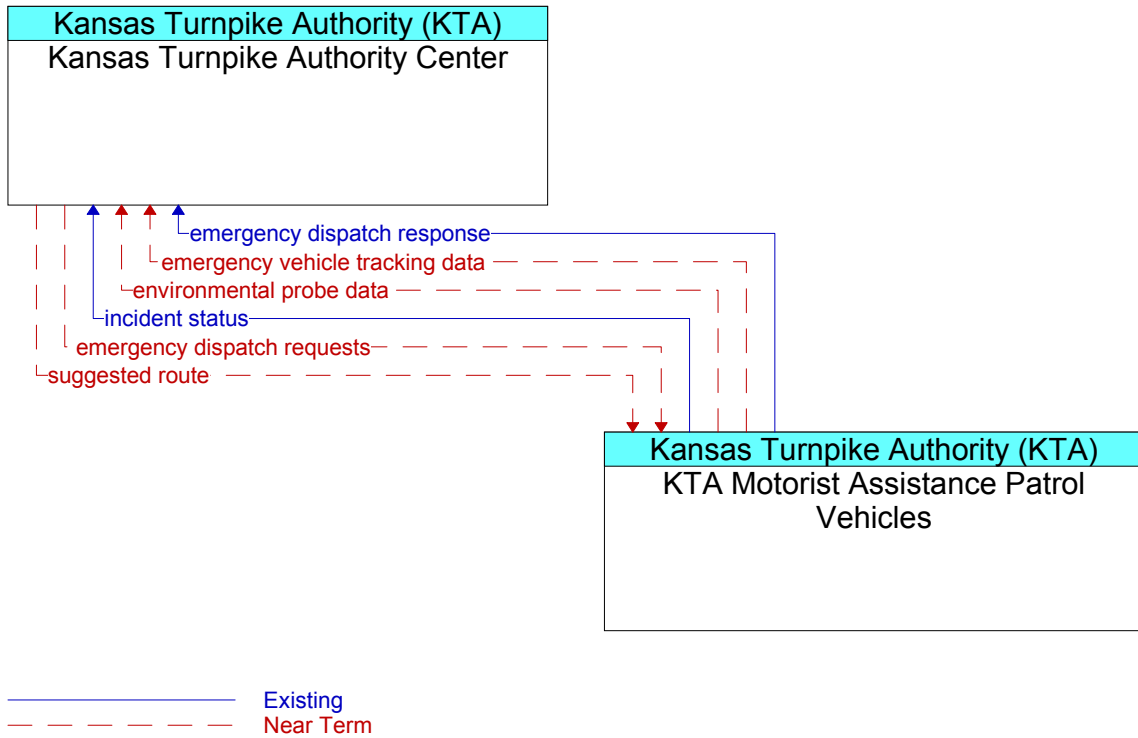


**Figure 38. KTA Maintenance Vehicle Communications Diagram**

There are currently 2 existing information flows established between the KTA Maintenance Vehicles and the KTA Center. In the near-term the KTA Vehicles will need to establish communications with the KTA Center. It is likely that KTA will expand their existing mobile communication infrastructure to meet their near term communication needs.

## 2.29 KTA Motorist Assistance Patrol Vehicles

The following diagram (Figure 39) shows all interfaces in the regional ITS architecture surrounding the KTA Motorist Assistance Patrol Vehicles element with annotated timeframes for expected communication content. The associated stakeholders are depicted on the top of each box containing an element.

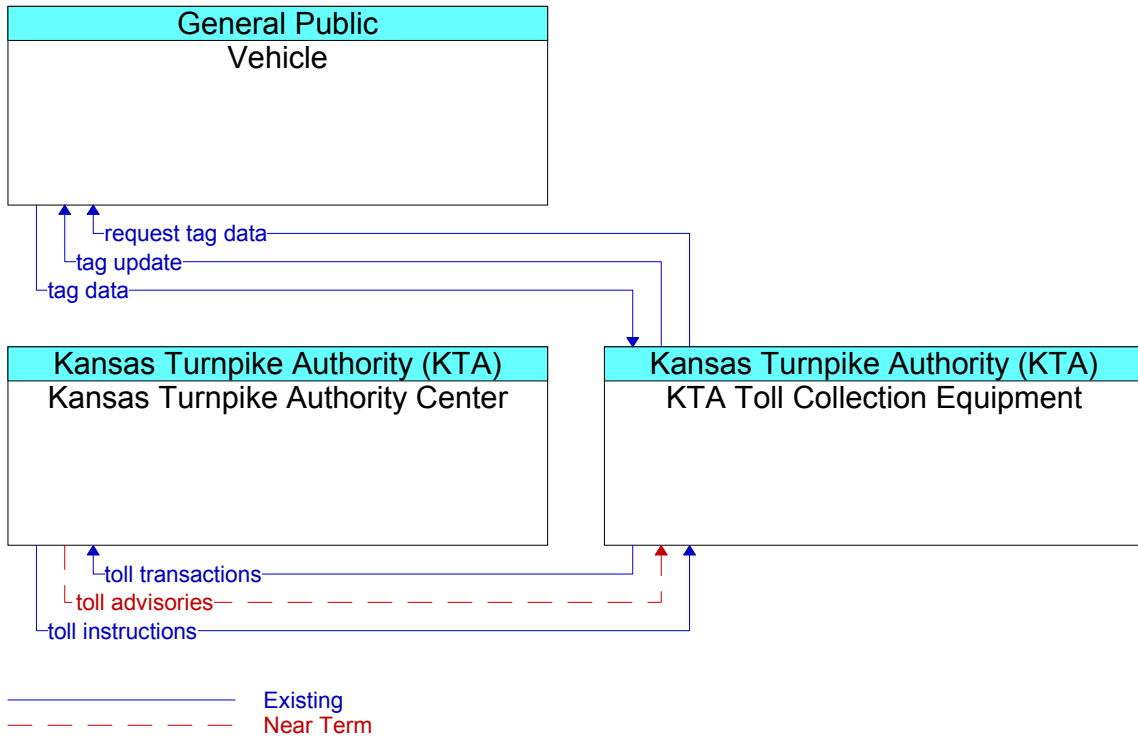


**Figure 39. KTA Motorist Assistance Patrol Vehicles Communications Diagram**

There are currently 2 existing information flows established between the KTA Motorist Assistance Patrol Vehicles and the KTA Center. In the near-term the KTA Motorist Assistance Patrol Vehicles will need to establish communications with the KTA Center. It is likely that KTA will expand their existing mobile communication infrastructure to meet their near term communication needs.

### 2.30 KTA Toll Collection Equipment

The following diagram (Figure 40) shows all interfaces in the regional ITS architecture surrounding the KTA Toll Collection Equipment element with annotated timeframes for expected communication content. The associated stakeholders are depicted on the top of each box containing an element.

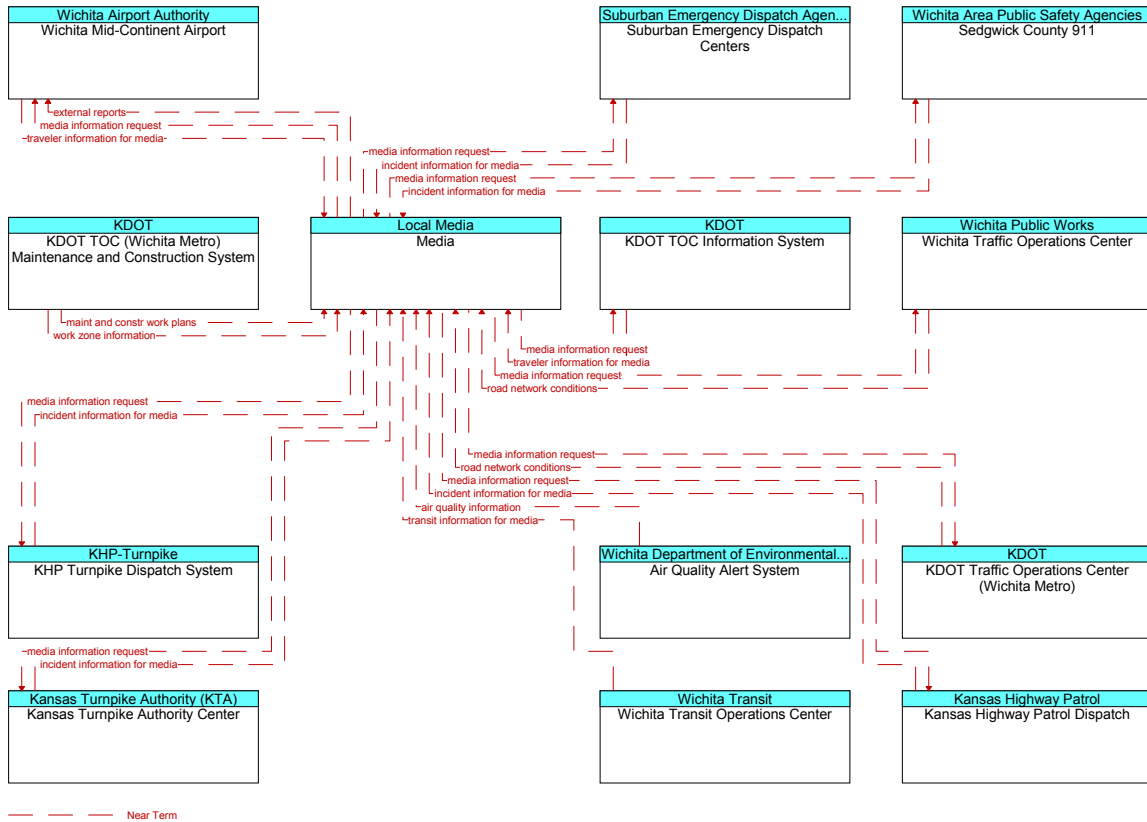


**Figure 40. KTA Toll Collection Equipment Communications Diagram**

There are currently 2 existing information flows established between the KTA Toll Collection Equipment and the KTA Center. In the near-term the KTA Center will need to establish new information flows with the KTA Toll Collection Equipment. It is likely that KTA will expand their existing communication infrastructure to meet their near term communication needs.

### 2.31 Media

The following diagram (Figure 41) shows all interfaces in the regional ITS architecture surrounding the Media element with annotated timeframes for expected communication content. The associated stakeholders are depicted on the top of each box containing an element.

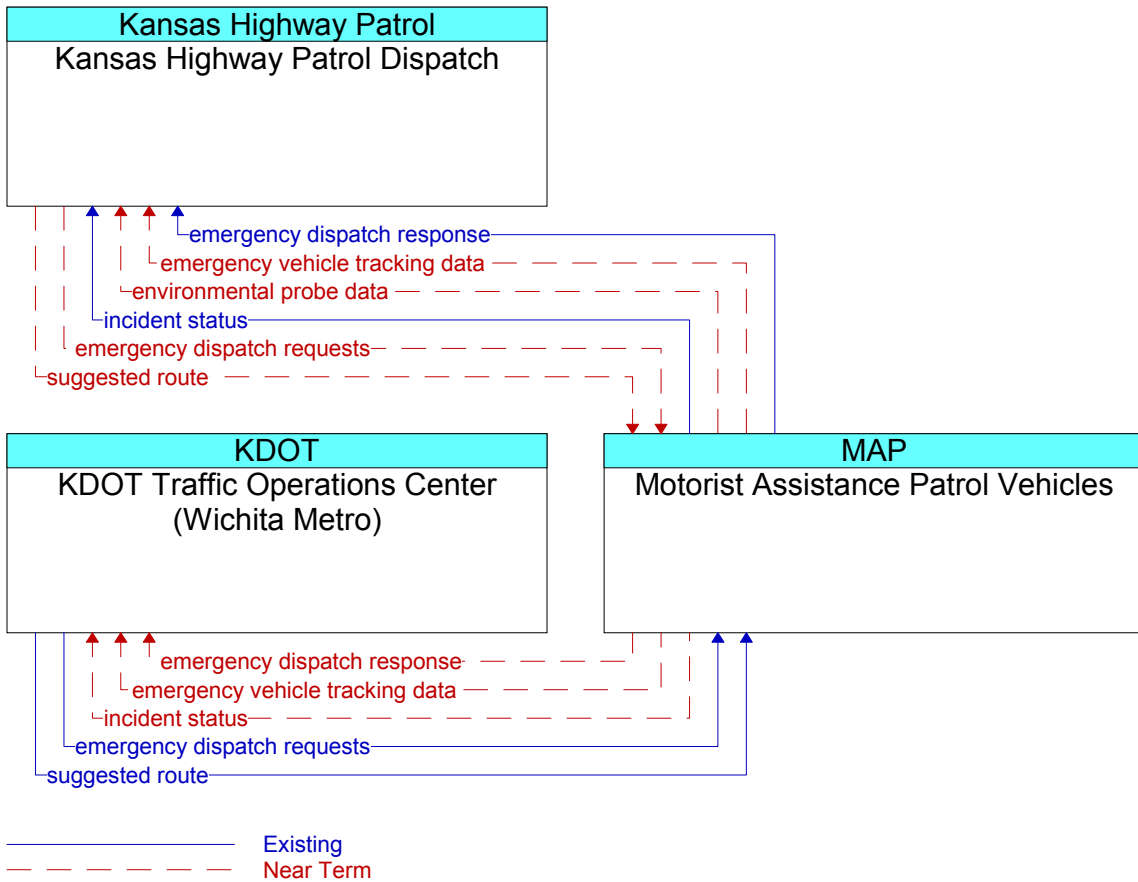


**Figure 41. Media Communications Diagram**

In the near term the Media needs to establish communication with many public sector agencies in the Wichita Metro area. It is likely that the media will establish leased lines to meet their communication needs.

### 2.32 Motorist Assistance Patrol Vehicles

The following diagram (Figure 42) shows all interfaces in the regional ITS architecture surrounding the Motorist Assistance Patrol (MAP) Vehicles element with annotated timeframes for expected communication content. The associated stakeholders are depicted on the top of each box containing an element.

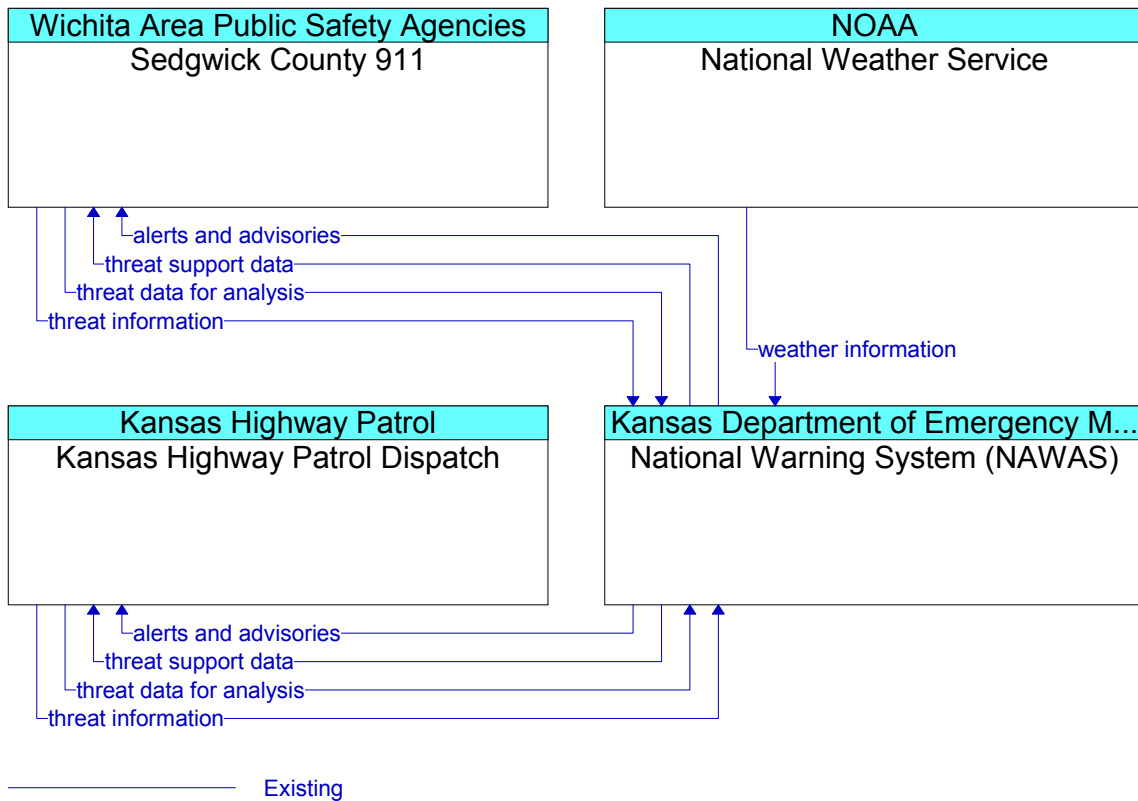


**Figure 42. Motorist Assistance Patrol (MAP) Vehicles Communications Diagram**

There are currently a few existing information flows established between MAP Vehicles and the KDOT TOC (Wichita Area) and KHP Dispatch. In the near-term the MAP Vehicles will need to expand communications with the KDOT TOC (Wichita Area) and KHP Dispatch. It is likely that MAP will expand their existing mobile communication infrastructure to meet their near term communication needs.

### 2.33 National Warning System (NAWAS)

The following diagram (Figure 43) shows all interfaces in the regional ITS architecture surrounding the National Warning System (NAWAS) element with annotated timeframes for expected communication content. The associated stakeholders are depicted on the top of each box containing an element.

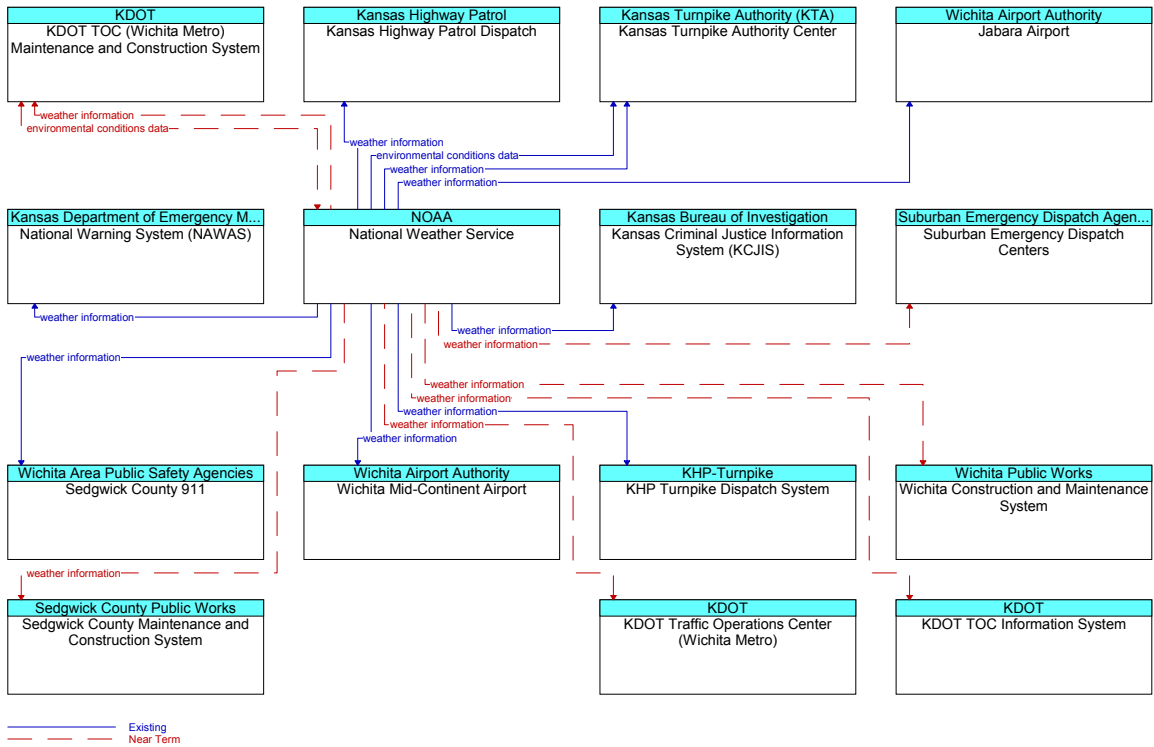


**Figure 43. National Warning System (NAWAS) Communications Diagram**

The National Warning System (NAWAS) currently has communication established among 3 other agencies and there is no need for new information flows. There is no communication expansion required or planned.

### 2.34 National Weather Service

The following diagram (Figure 44) shows all interfaces in the regional ITS architecture surrounding the National Weather Service element with annotated timeframes for expected communication content. The associated stakeholders are depicted on the top of each box containing an element.



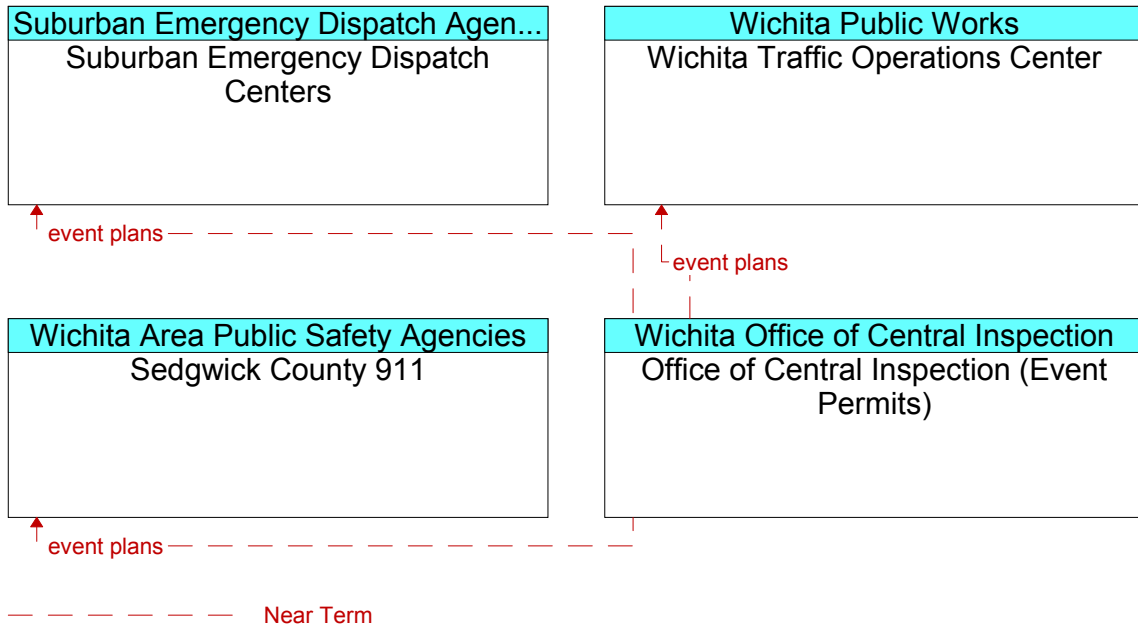
**Figure 44. National Weather Service Communications Diagram**

In the near-term there is a need for the National Weather Service to add new information flows and establish communication with several new agencies. It is likely that the National Weather Service will establish leased line service to the agencies that they will be interfacing with.

### 2.35 Office of Central Inspection (Event Permits)

The following diagram (Figure 45) shows all interfaces in the regional ITS architecture surrounding the Office of Central Inspection (Event Permits) element with annotated timeframes for expected communication content. The associated stakeholders are depicted on the top of each box containing an element.



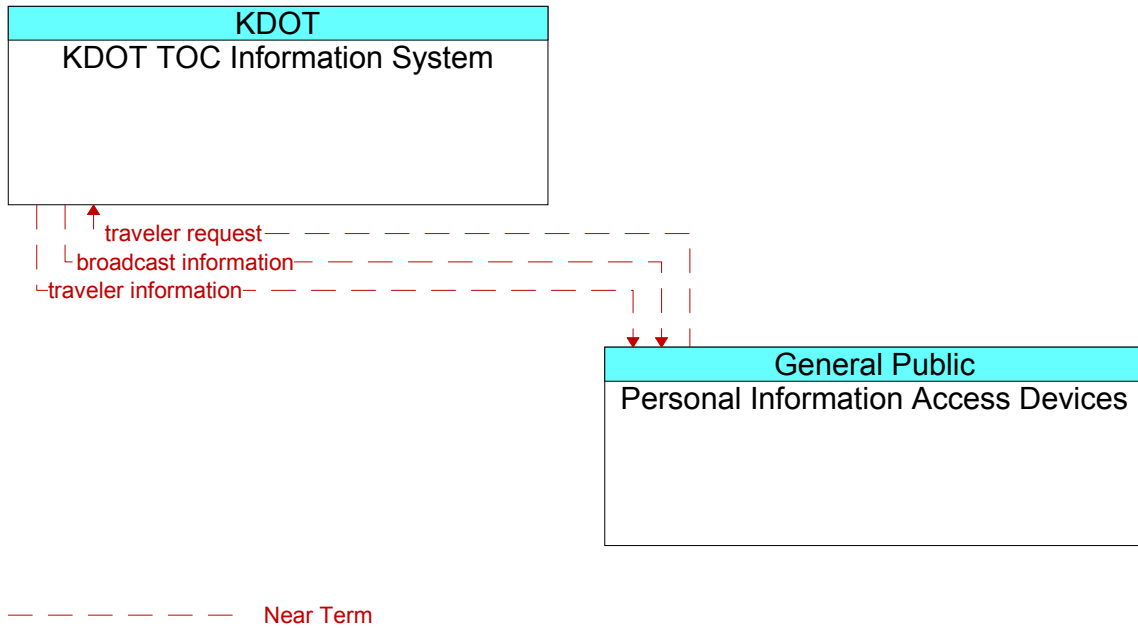


**Figure 45. Office of Central Inspection (Event Permits) Communications Diagram**

In the near-term there is a need for the Office of Central Inspection (Event Permits) to add new outbound information flows and establish communication with several agencies. It is likely that the Office of Central Inspection (Event Permits) will establish leased line service to the agencies that they will be interfacing with.

### 2.36 Personal Information Access Devices

The following diagram (Figure 46) shows all interfaces in the regional ITS architecture surrounding the Personal Information Access Device element with annotated timeframes for expected communication content. The associated stakeholders are depicted on the top of each box containing an element.

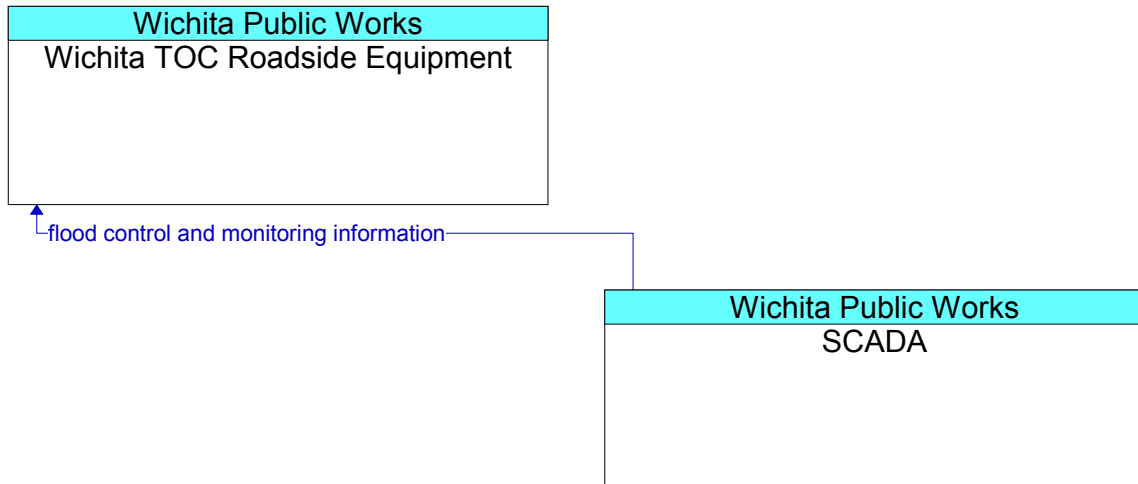


**Figure 46. Personal Information Access Device Communications Diagram**

Although the personal information access device can be used for many wireless applications, the primary interface will be to the KDOT TOC Information System within the Wichita region.

### 2.37 SCADA

The following diagram (Figure 47) shows all interfaces in the regional ITS architecture surrounding the SCADA element with annotated timeframes for expected communication content. The associated stakeholders are depicted on the top of each box containing an element.



Existing

**Figure 47. SCADA Communications Diagram**

The Wichita Public Works SCADA System currently has point-to-point communication established through the Wichita TOC Roadside Equipment providing flood monitoring and control data to the Wichita TOC.

### **2.38 Sedgwick County 911**

The following diagram (Figure 48, Figure 49 and Figure 50) shows all interfaces in the regional ITS architecture surrounding the Sedgwick County 911 element with annotated timeframes for expected communication content. The associated stakeholders are depicted on the top of each box containing an element.

The Sedgwick County 911 system is one of the more complex elements with regard to communications. The communications received from the 911 call-in number by the Sedgwick County 911 system is by telephone. The diagram below shows the phasing of electronic communication with the myriad of elements interfacing with the Sedgwick County 911 system.

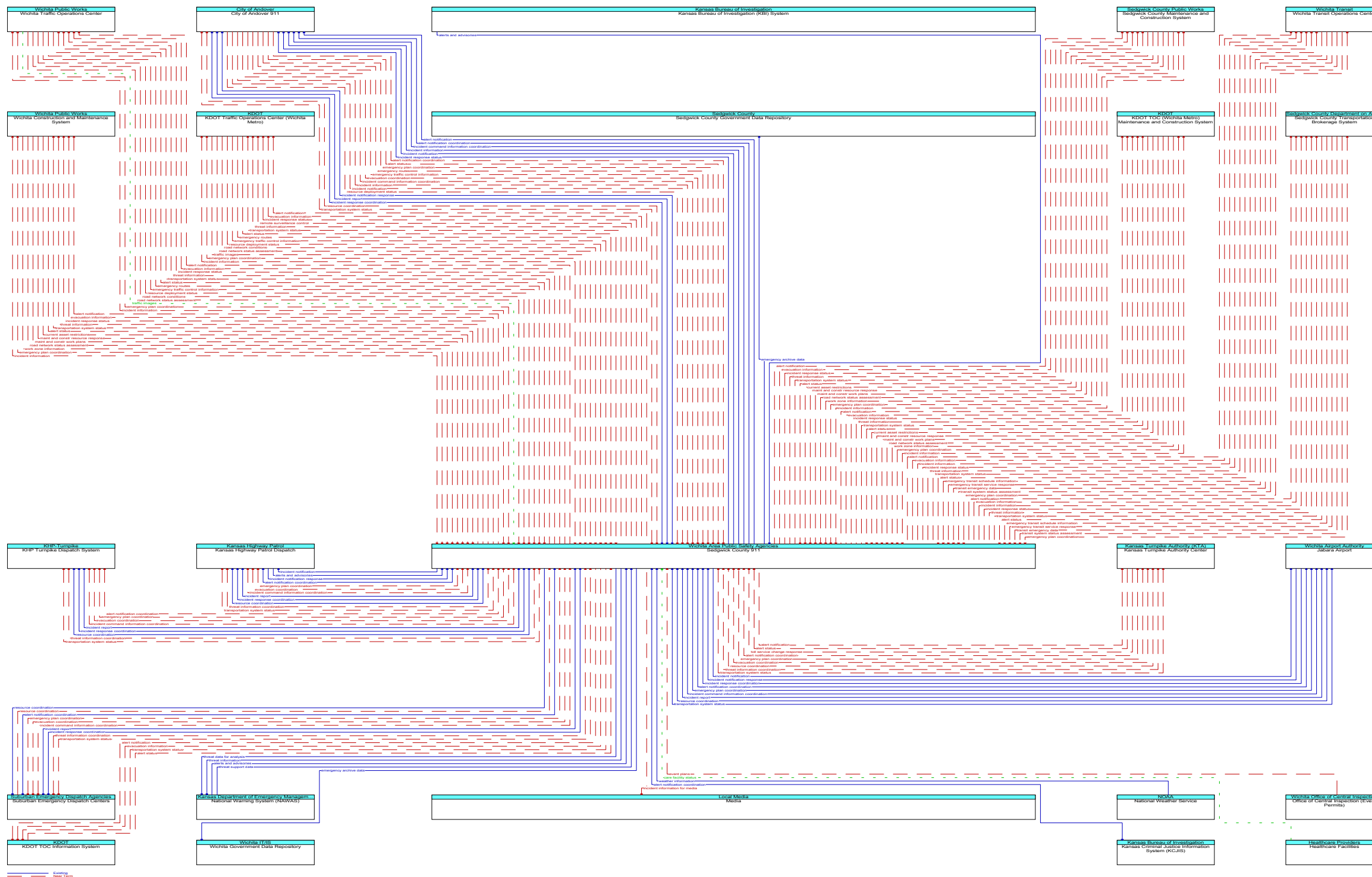
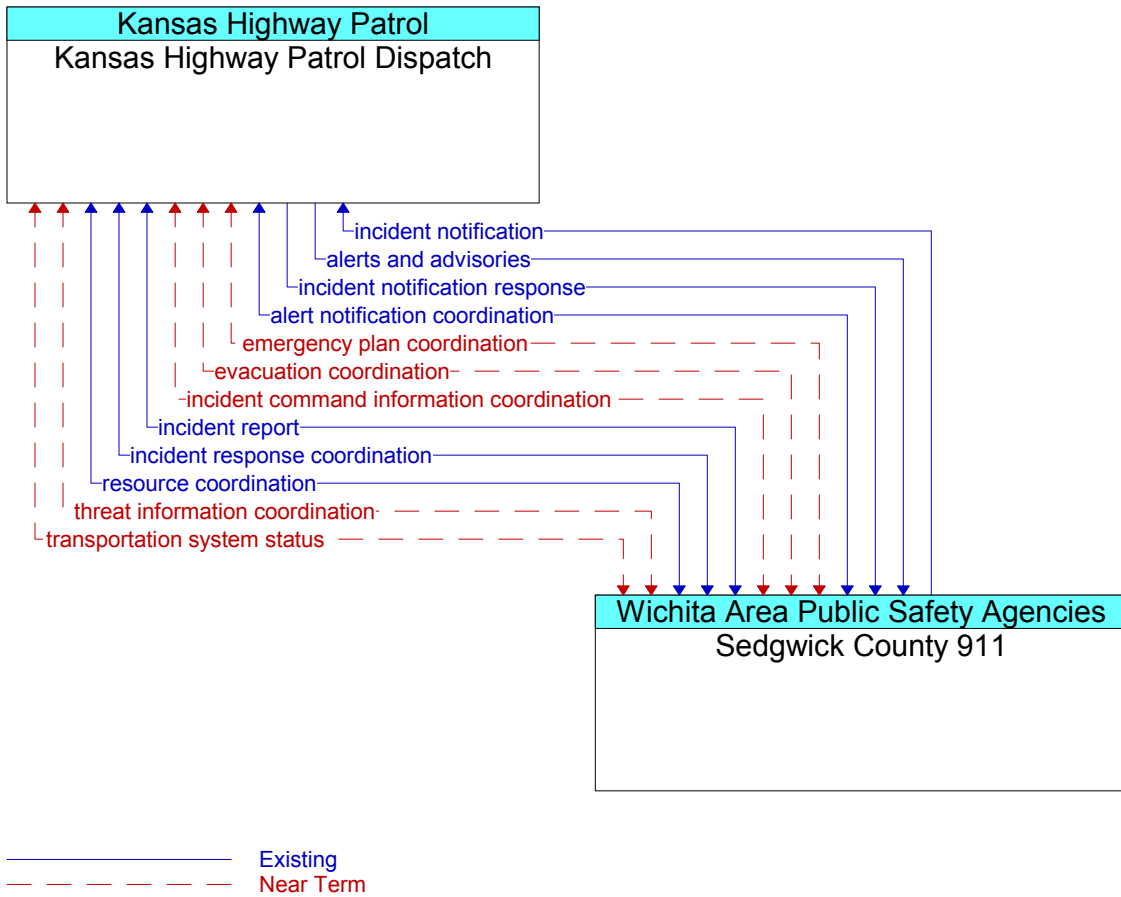


Figure 48. Sedgwick County 911 Diagram (Part 1)



**Figure 49. Sedgwick County 911 Diagram (Part 2)**

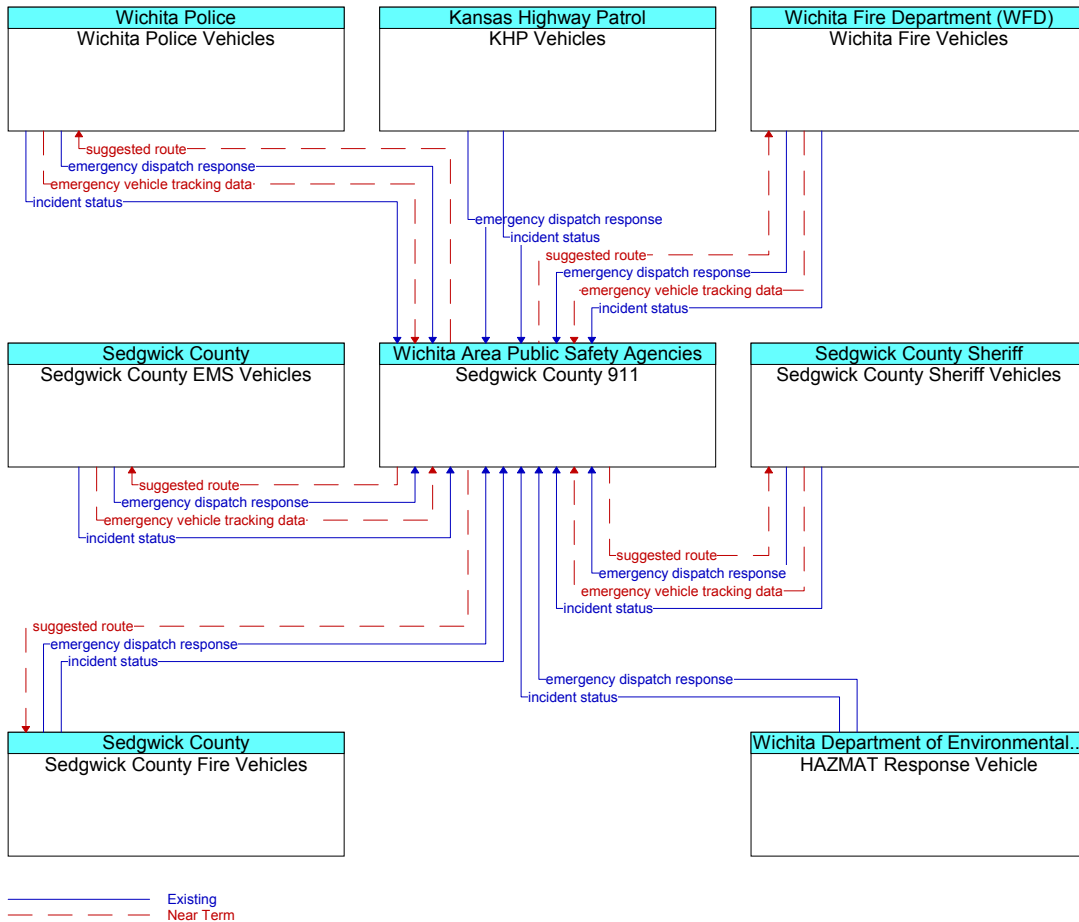


Figure 50. Sedgwick County 911 Diagram (Part 3)

### 2.39 Sedgwick County EMS Vehicles

The following diagram (Figure 51) shows all interfaces in the regional ITS architecture surrounding the Sedgwick County EMS Vehicles element with annotated timeframes for expected communication content. The associated stakeholders are depicted on the top of each box containing an element.

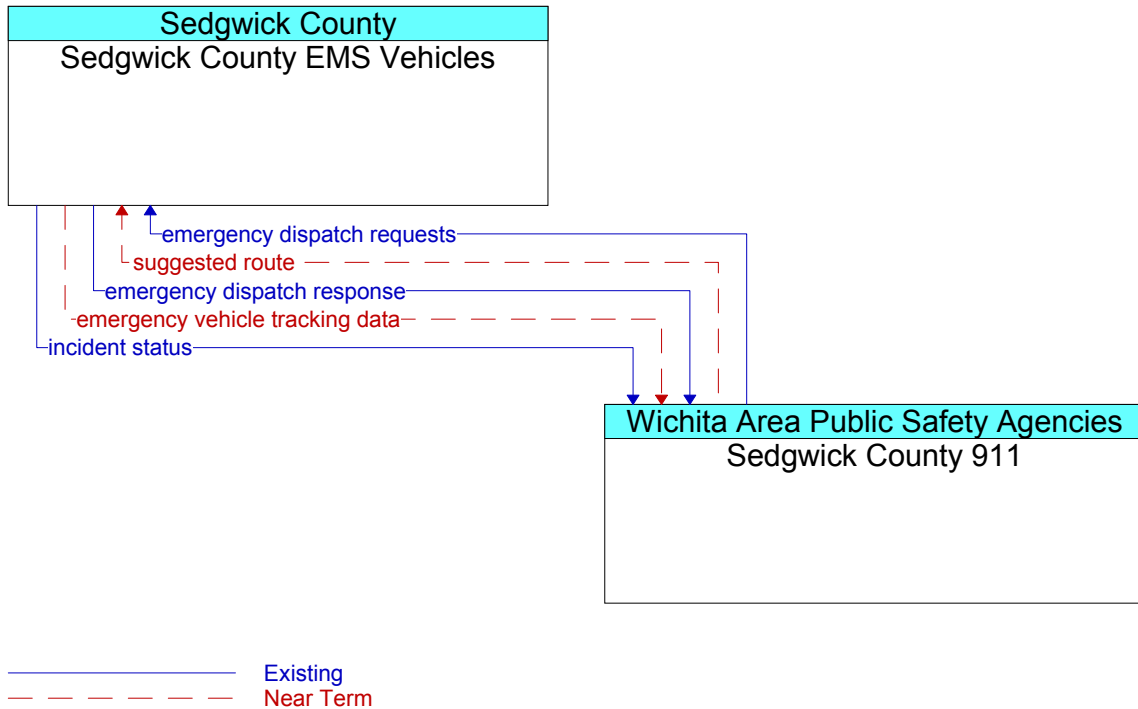


Figure 51. Sedgwick County EMS Vehicles Diagram

The communications between the Sedgwick County EMS Vehicles and the Sedgwick County 911 center includes incident and dispatch response (it is assumed that there are request flows for this information, they are not shown) information with a future capability for vehicle tracking and suggested routes. This is a wireless communication interface, most likely using 800MHz data exchanges.

## 2.40 Sedgwick County Fire Vehicles

The following diagram (Figure 52) shows all interfaces in the regional ITS architecture surrounding the Sedgwick County Fire Vehicles element with annotated timeframes for expected communication content. The associated stakeholders are depicted on the top of each box containing an element.

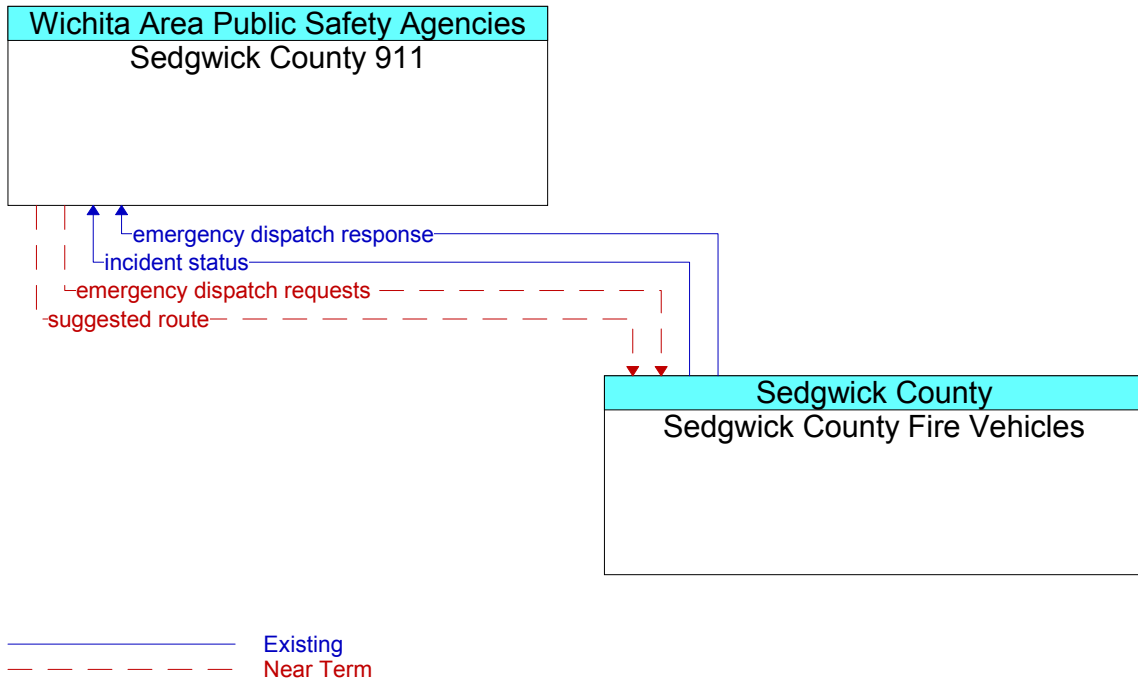


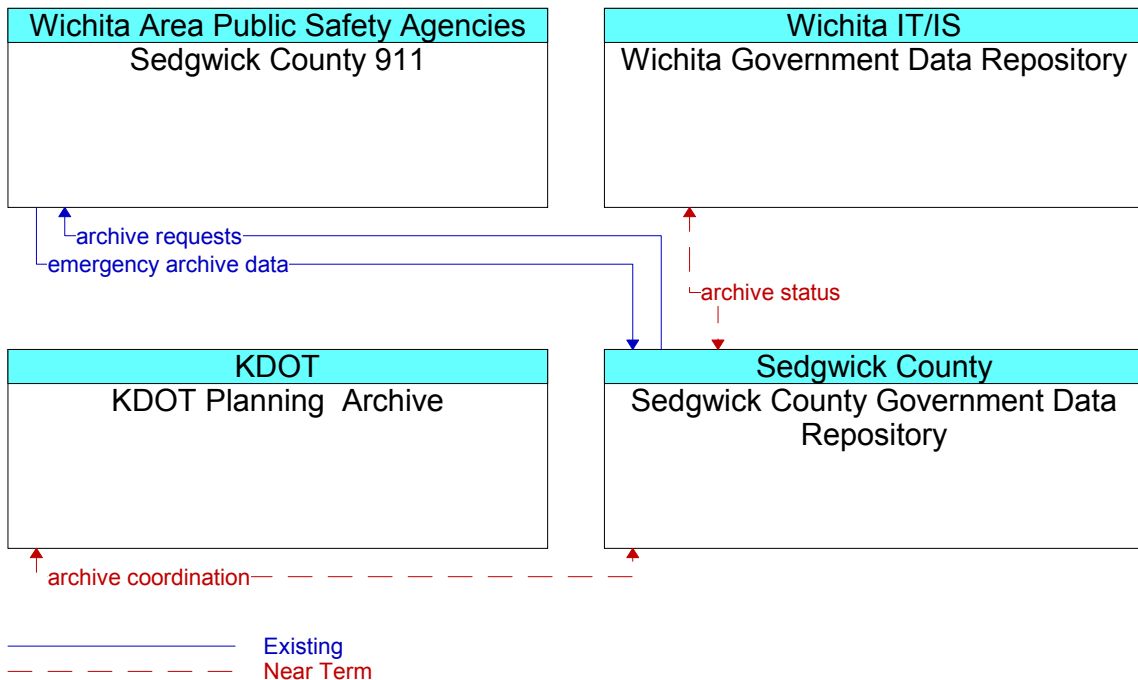
Figure 52. Sedgwick County Fire Vehicles Diagram

The communications between the Sedgwick County Fire Vehicles and the Sedgwick County 911 center includes incident and dispatch response (it is assumed that there are request flows for this information, they are not shown) information with a future capability for suggested routes. This is a wireless communication interface, most likely using 800MHz data exchanges.

## 2.41 Sedgwick County Government Data Repository

The following diagram (Figure 53) shows all interfaces in the regional ITS architecture surrounding the Sedgwick County Government Data Repository element with annotated timeframes for expected communication content. The associated stakeholders are depicted on the top of each box containing an element.





**Figure 53. Sedgwick County Government Data Repository Diagram**

The communications between the Sedgwick County Government Data Repository and the Sedgwick County 911 center, KDOT Planning Archive and the Wichita Government Data Repository includes the exchange of archive information with a future capability for the City of Wichita and KDOT. This is a point-to-point communication interface, most likely based on the large amount of information using fiber.

## 2.42 Sedgwick County Maintenance and Construction System

The following diagram (Figure 54, Figure 55 and Figure 56) shows all interfaces in the regional ITS architecture surrounding the Sedgwick County Maintenance and Construction System element with annotated timeframes for expected communication content. The associated stakeholders are depicted on the top of each box containing an element.

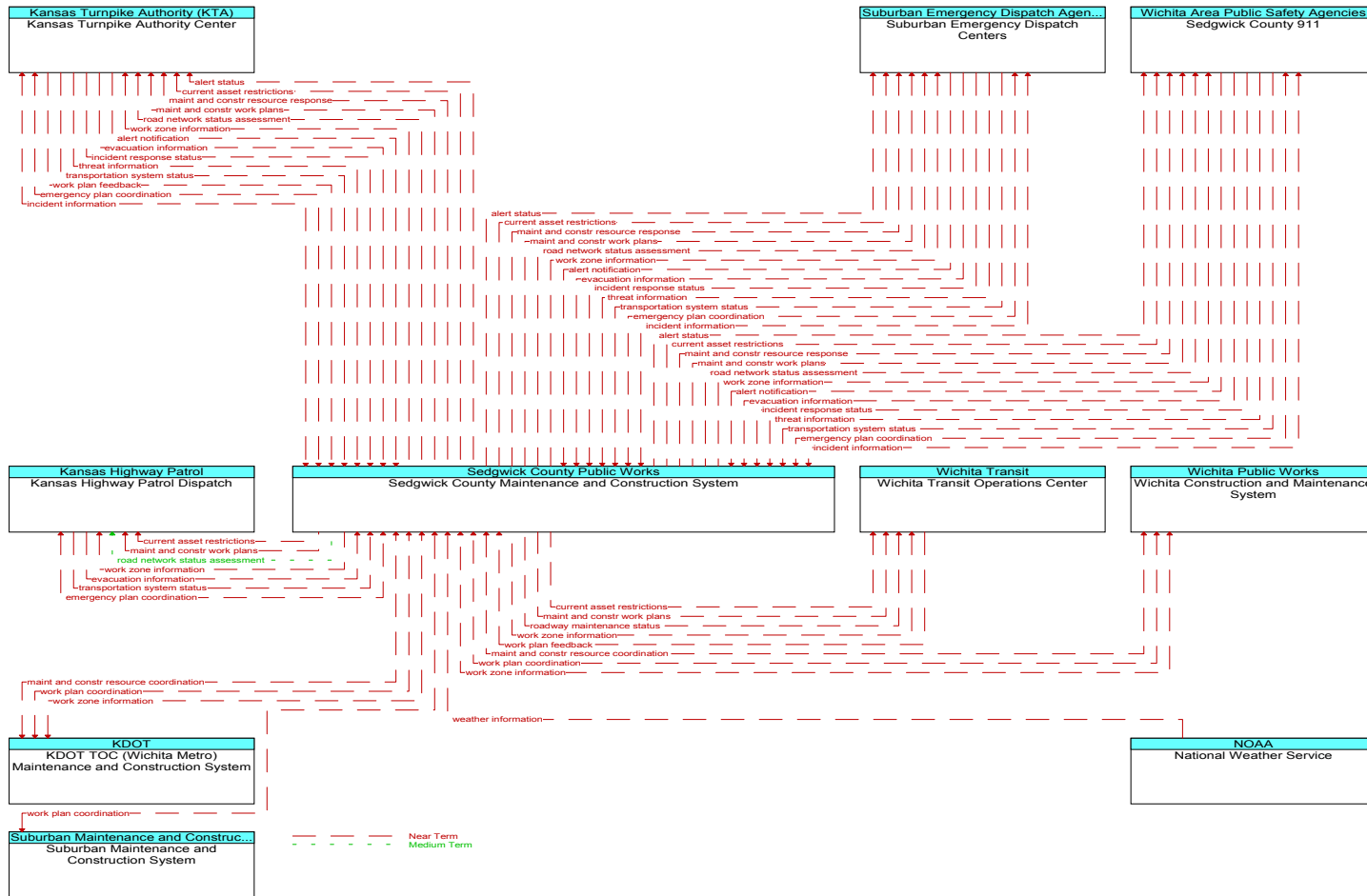
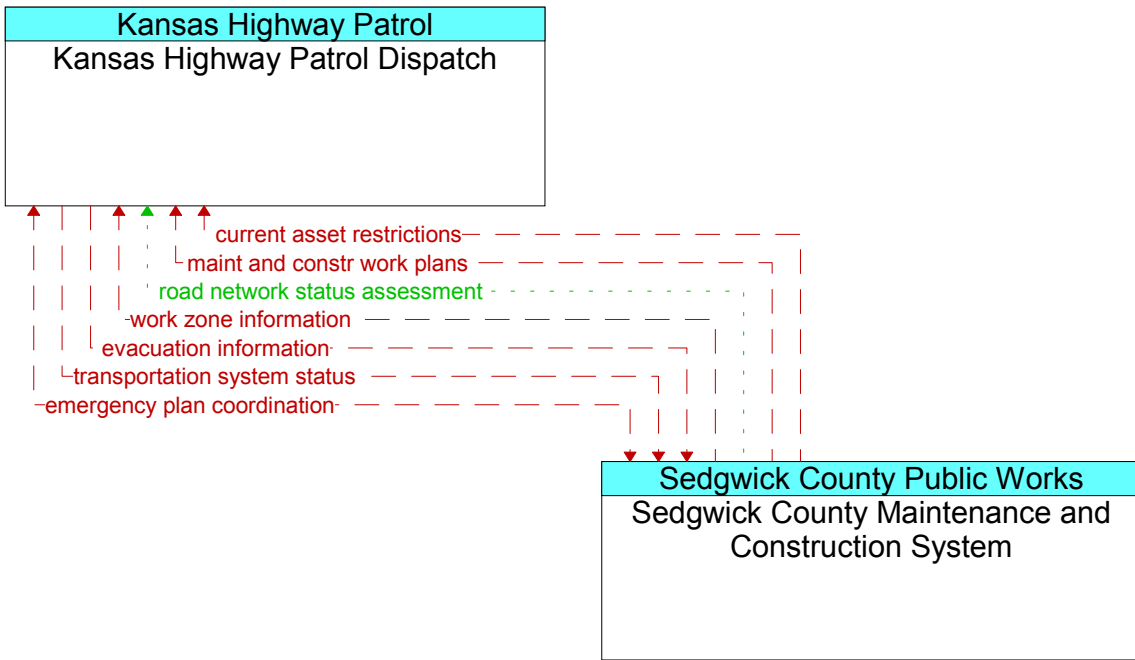
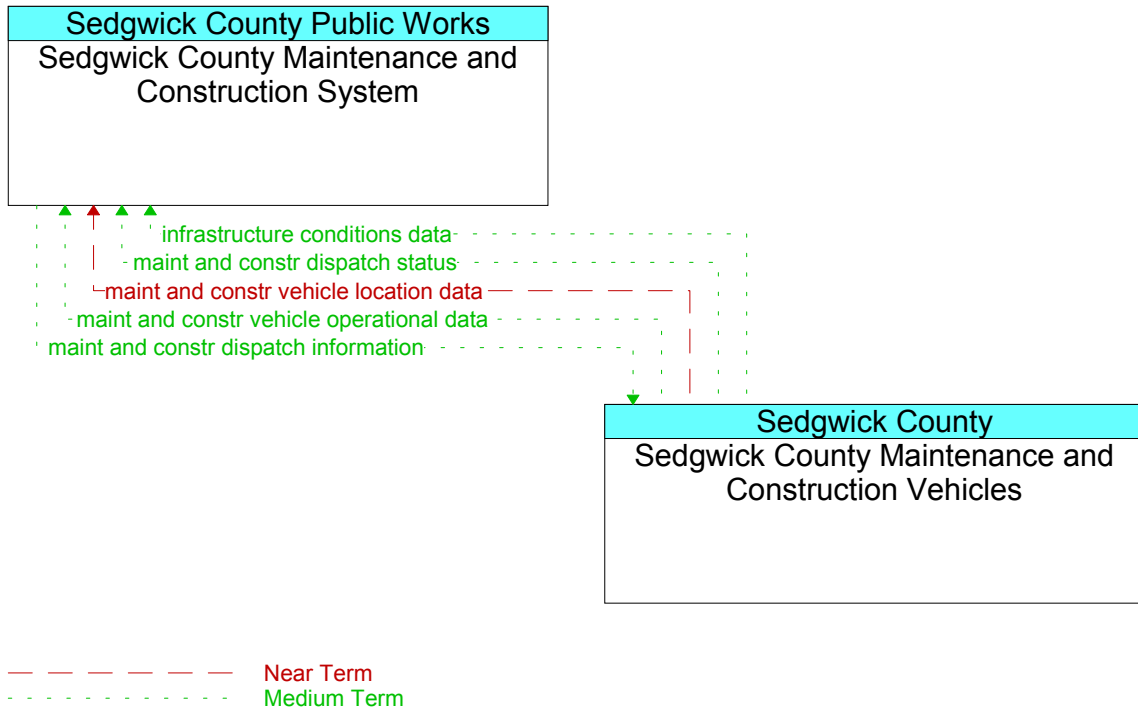


Figure 54. Sedgwick County Maintenance and Construction System Diagram (Part 1)



--- Near Term  
- - - Medium Term

**Figure 55. Sedgwick County Maintenance and Construction System Diagram (Part 2)**

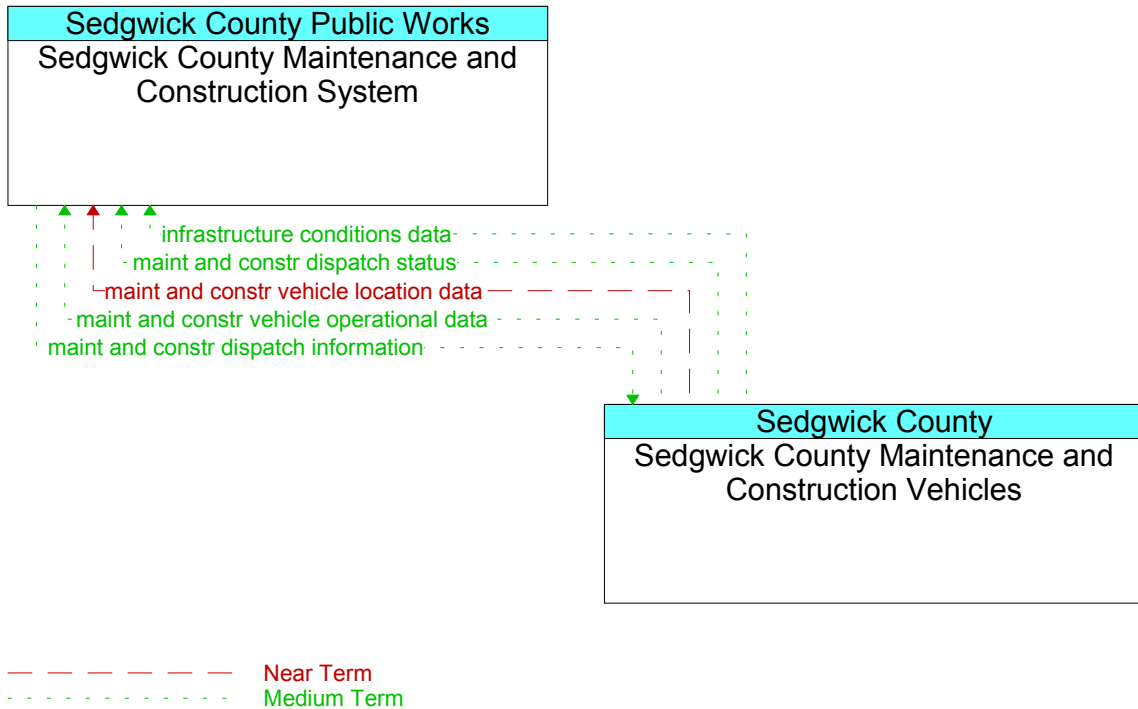


**Figure 56. Sedgwick County Maintenance and Construction System Diagram (Part 3)**

The communications between the Sedgwick County Maintenance and Construction System and the various elements providing or requiring maintenance and construction includes maintenance and construction vehicle and dispatch (it is assumed that there are request flows for this information, they are not shown) information.. This is a point-to-point communication interface, most likely, based on the need for transfers of large amounts of information, using fiber.

### 2.43 Sedgwick County Maintenance and Construction Vehicles

The following diagram (Figure 57) shows all interfaces in the regional ITS architecture surrounding the Sedgwick County Maintenance and Construction Vehicles element with annotated timeframes for expected communication content. The associated stakeholders are depicted on the top of each box containing an element.

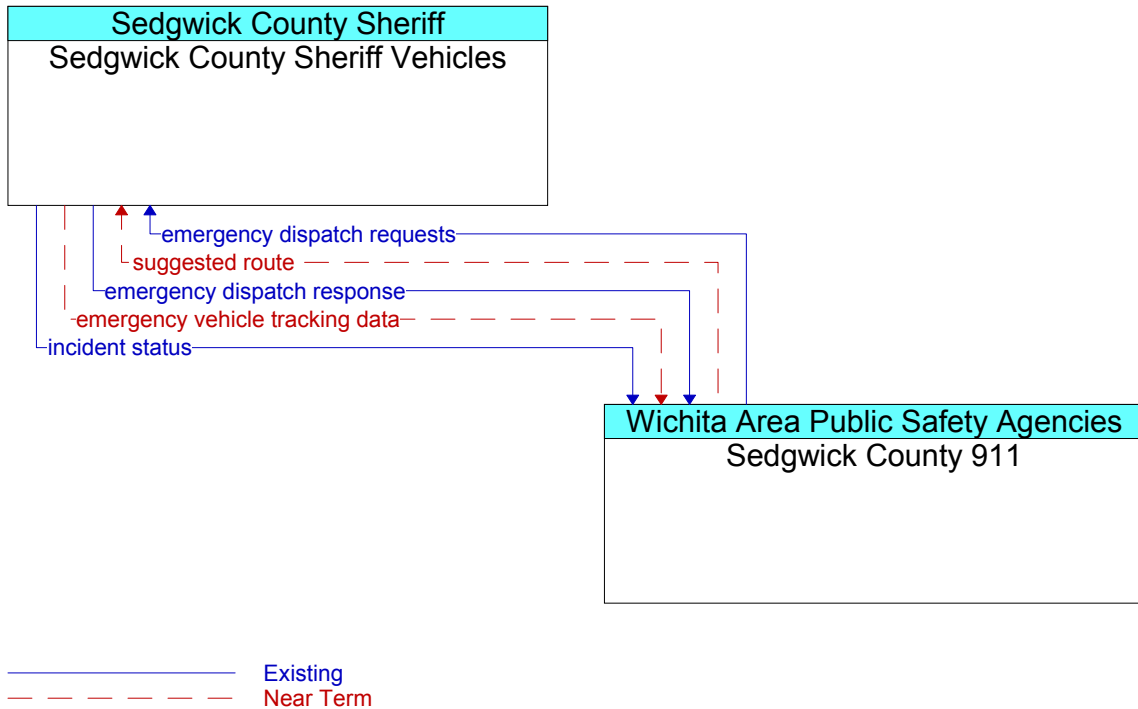


**Figure 57. Sedgwick County Maintenance and Construction Vehicles Diagram**

The communications between the Sedgwick County Maintenance and Construction Vehicles and the Sedgwick County Maintenance and Construction System includes maintenance and construction vehicle and dispatch (it is assumed that there are request flows for this information, they are not shown) information. This is a wireless communication interface, most likely using 800MHz data exchanges.

## 2.44 Sedgwick County Sheriff Vehicles

The following diagram (Figure 58) shows all interfaces in the regional ITS architecture surrounding the Sedgwick County Sheriff Vehicles element with annotated timeframes for expected communication content. The associated stakeholders are depicted on the top of each box containing an element.

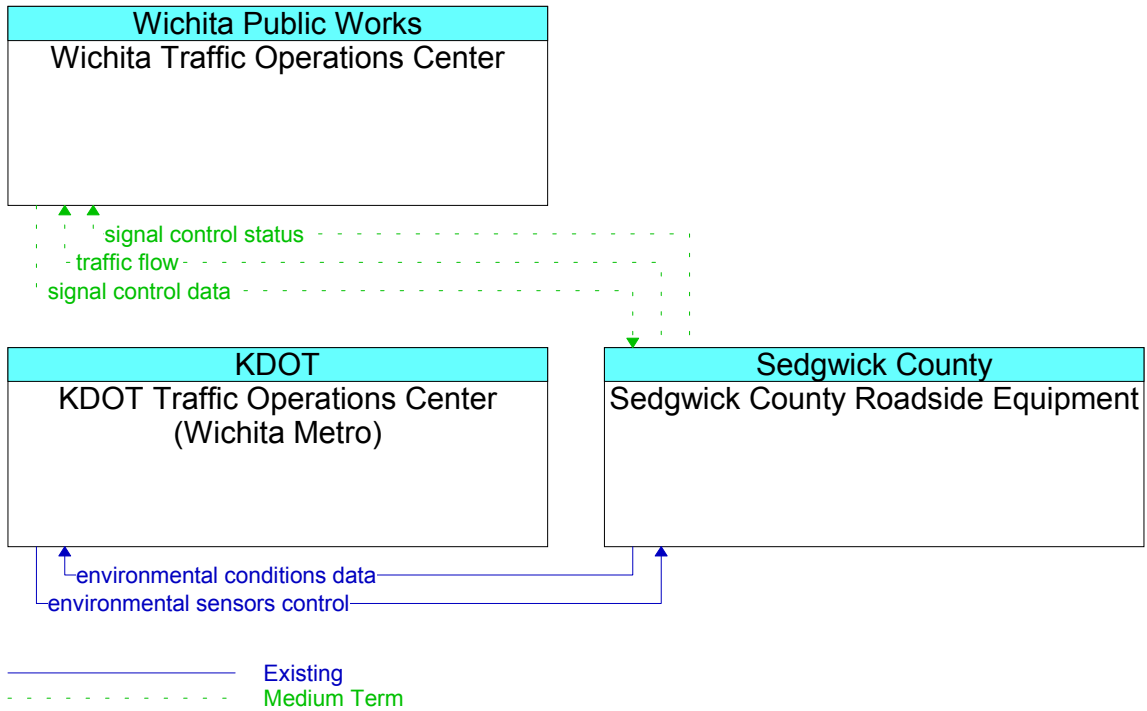


**Figure 58. Sedgwick County Sheriff Vehicles Diagram**

The communications between the Sedgwick County Sheriff Vehicles and the Sedgwick County 911 center includes incident and dispatch response (it is assumed that there are request flows for this information, they are not shown) information with a future capability for suggested routes and vehicle tracking. This is a wireless communication interface, most likely using 800MHz data exchanges.

### 2.45 Sedgwick County TOC Roadside Equipment

The following diagram (Figure 59) shows all interfaces in the regional ITS architecture surrounding the Sedgwick County TOC Roadside Equipment element with annotated timeframes for expected communication content. Sedgwick County does not have a TOC; the Wichita TOC will be controlling Sedgwick County’s roadside equipment in the future. The associated stakeholders are depicted on the top of each box containing an element.

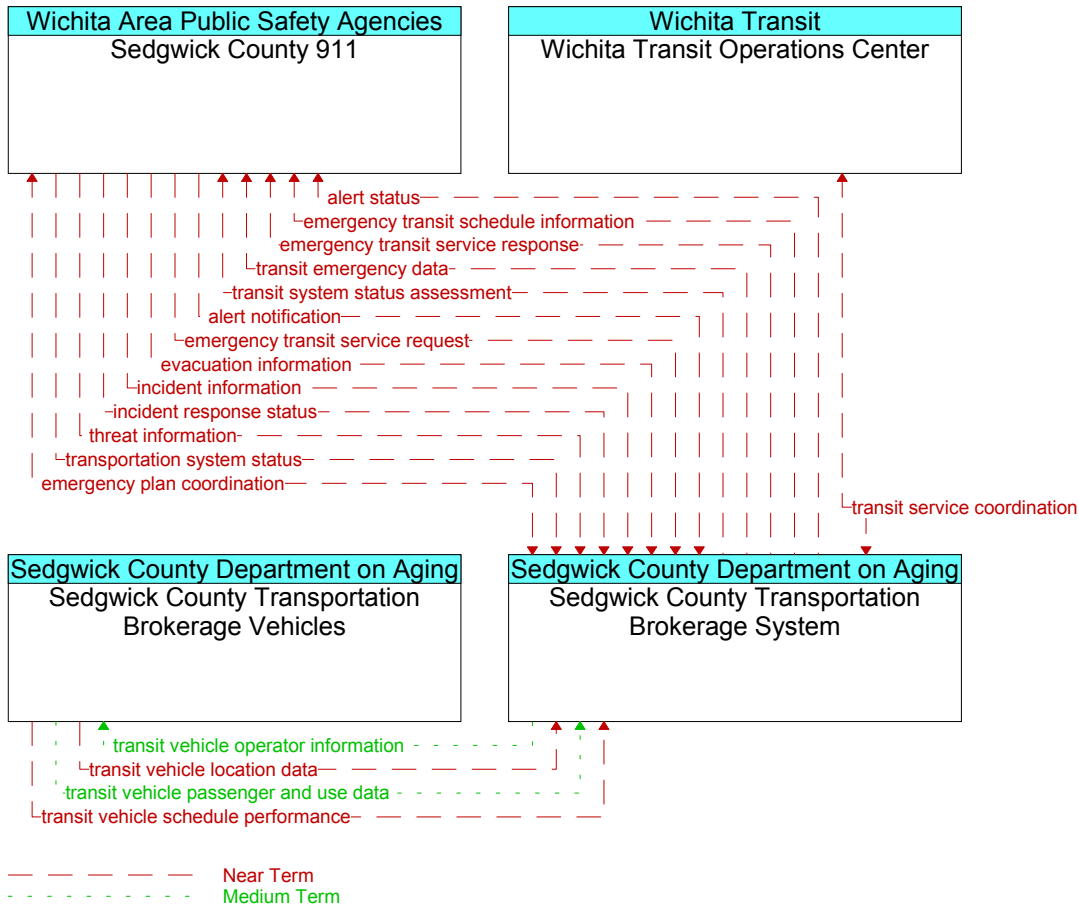


**Figure 59. Sedgwick County TOC Roadside Equipment Diagram**

The communications between the Sedgwick County TOC Roadside Equipment and the Wichita Traffic operations Center includes signal control and traffic flow (it is assumed that there are request flows for this information, they are not shown) information with an existing capability of sending KDOT its RWIS environmental information. The signal control study should further define the specific signal control communications needs.

## 2.46 Sedgwick County Transportation Brokerage System and Vehicles

The following diagram (Figure 60) shows all interfaces in the regional ITS architecture surrounding the Sedgwick County Transportation Brokerage System and Vehicles element with annotated timeframes for expected communication content. The associated stakeholders are depicted on the top of each box containing an element.



**Figure 60. Sedgwick County Transportation Brokerage System and Vehicles Diagram**

The communications between the Sedgwick County Transportation Brokerage System and its Vehicles is wireless and will contain transit vehicle location and schedule performance data in the near-term and more specific passenger and use data along with transit vehicle operator instructions in the medium-term. The Brokerage System also coordinates with Wichita Transit and sends and receives incident information to and from the Sedgwick County 911 system.

## 2.47 Suburban Emergency Dispatch Centers

The following diagram (Figure 61 and Figure 62) shows all interfaces in the regional ITS architecture surrounding the Suburban Emergency Dispatch Centers element with annotated timeframes for expected communication content. This element is a collection of all call centers besides the Sedgwick County 911 and the City of Andover 911 centers. The associated stakeholders are depicted on the top of each box containing an element.



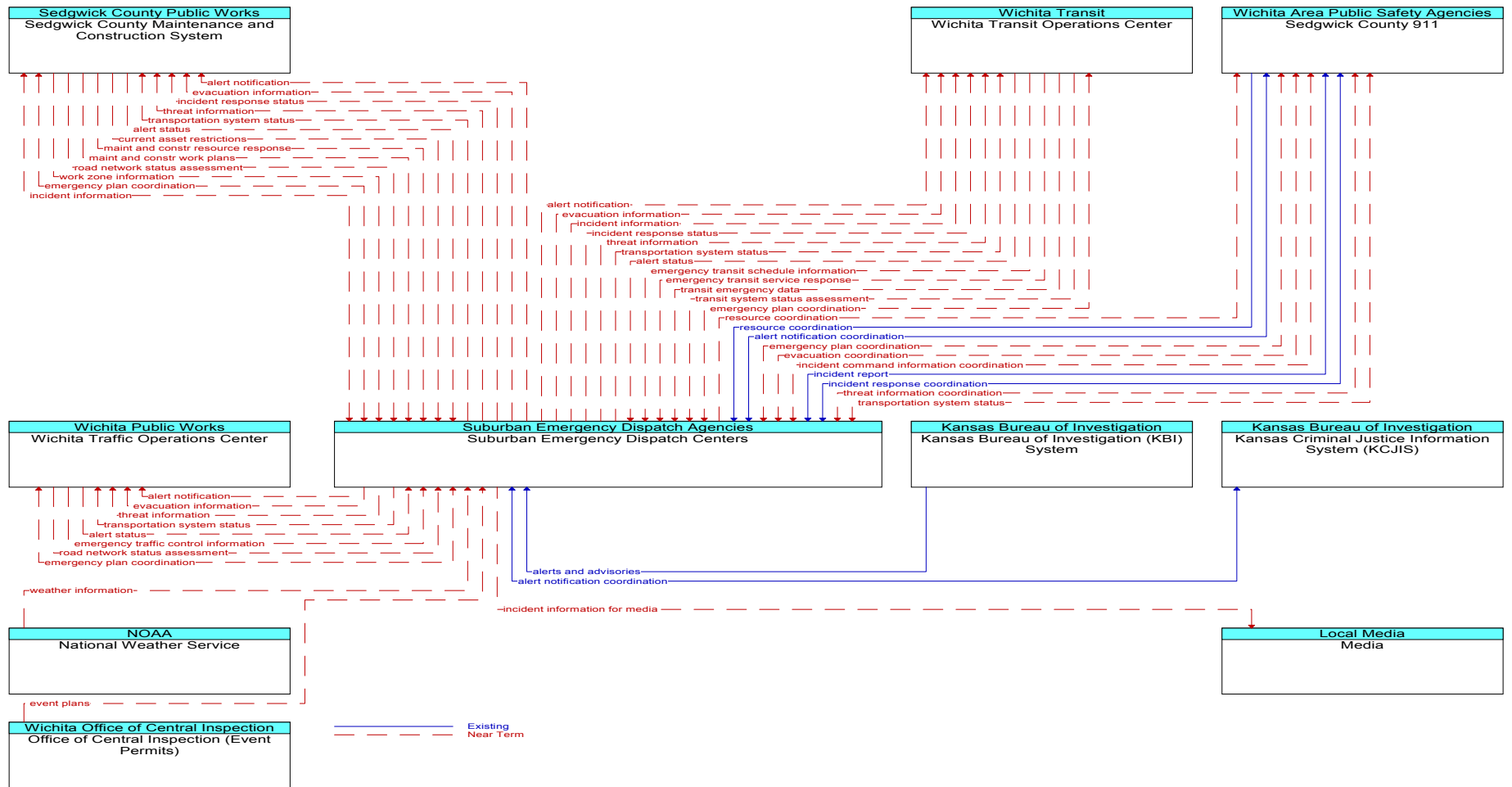
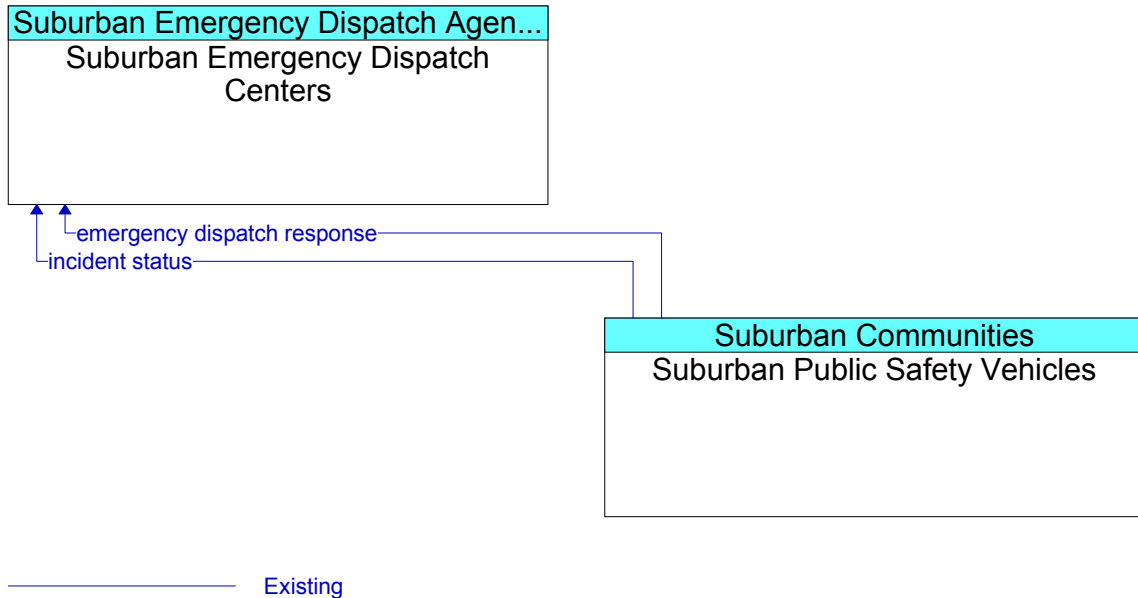


Figure 61. Suburban Emergency Dispatch Centers Diagram (Part 1)

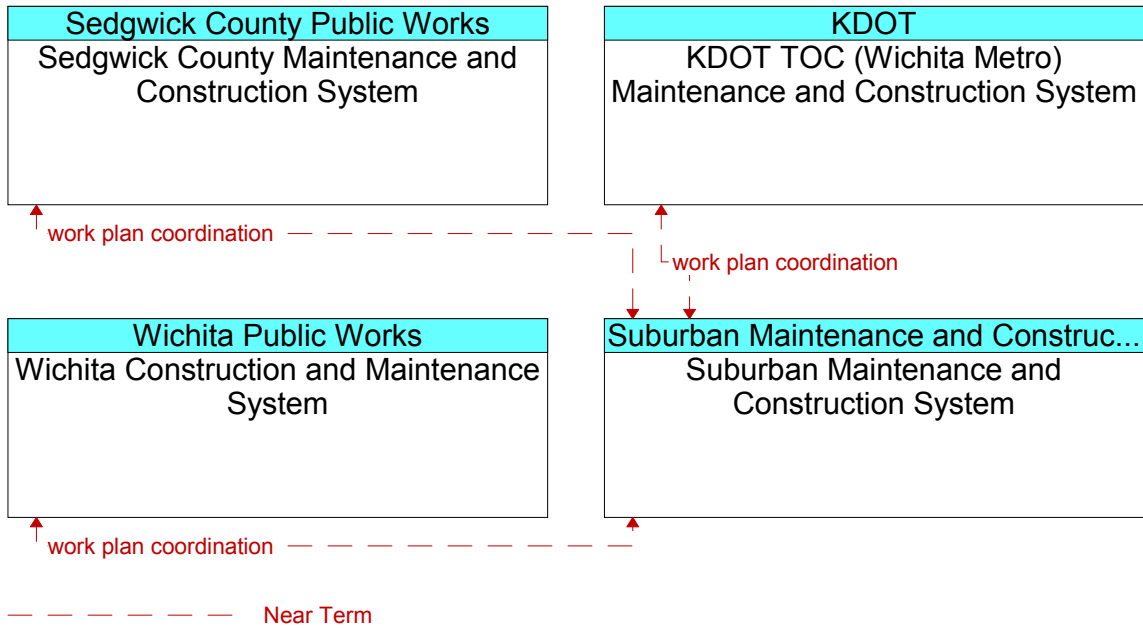


**Figure 62. Suburban Emergency Dispatch Centers Diagram (Part 2)**

The Suburban Emergency Dispatch Centers receive information from the 911 call-in number by telephone. The diagram below shows the phasing of electronic communication with the myriad of elements interfacing with the Suburban Emergency Dispatch Centers.

## 2.48 Suburban Maintenance and Construction System

The following diagram (Figure 63) shows all interfaces in the regional ITS architecture surrounding the Sedgwick County Maintenance and Construction System element with annotated timeframes for expected communication content. The associated stakeholders are depicted on the top of each box containing an element.

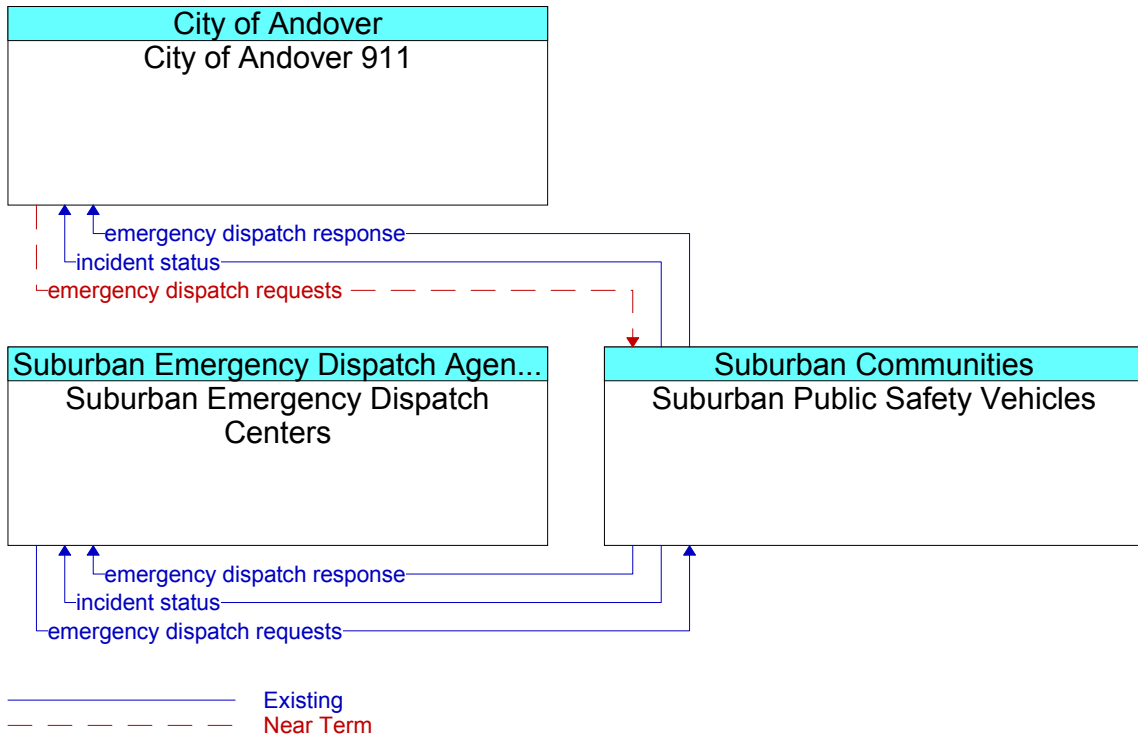


**Figure 63. Suburban Maintenance and Construction System Diagram**

The communications between the Sedgwick County Maintenance and Construction System and the various elements providing or requiring maintenance and construction includes maintenance and construction vehicle and dispatch (it is assumed that there are request flows for this information, they are not shown) information. This is a point-to-point communication interface, most likely, based on the need for transfers of large amounts of information, using fiber.

## 2.49 Suburban Public Safety Vehicles

The following diagram (Figure 64) shows all interfaces in the regional ITS architecture surrounding the Suburban Public Safety Vehicles element with annotated timeframes for expected communication content. The associated stakeholders are depicted on the top of each box containing an element.

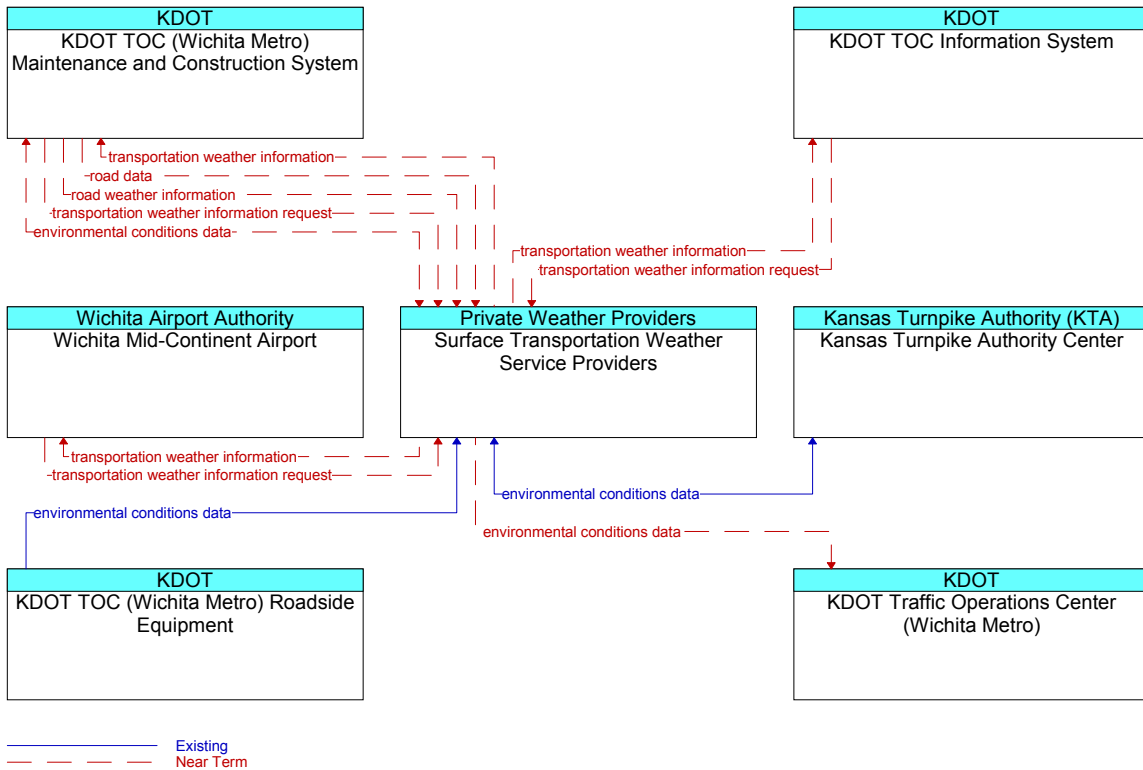


**Figure 64. Suburban Public Safety Vehicles Diagram**

The communications between the Suburban Public Safety Vehicles and the Suburban Emergency Dispatch Centers along with the City of Andover 911 center includes incident and dispatch response (it is assumed that there are request flows for this information, they are not shown) information with a future capability for suggested routes and vehicle tracking. This is a wireless communication interface, most likely using 800MHz data exchanges.

## 2.50 Surface Transportation Weather Service Providers

The following diagram (Figure 65) shows all interfaces in the regional ITS architecture surrounding the Surface Transportation Weather Service Providers element with annotated timeframes for expected communication content. The associated stakeholders are depicted on the top of each box containing an element.

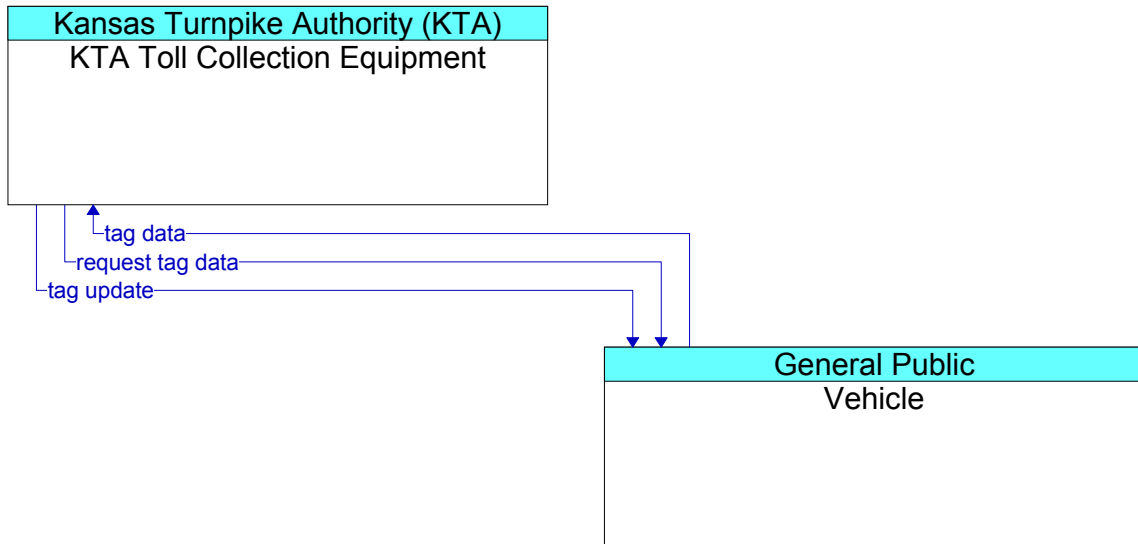


**Figure 65. Surface Transportation Weather Service Providers Communications Diagram**

The communications between the Surface Transportation Weather Service Providers and the various elements requiring value-added private sector weather information. This is a point-to-point communication interface, most likely, based on the need for transfer of time critical weather information.

## 2.51 Vehicle

The following diagram (Figure 66) shows all interfaces in the regional ITS architecture surrounding the Vehicle element with annotated timeframes for expected communication content. The associated stakeholders are depicted on the top of each box containing an element.



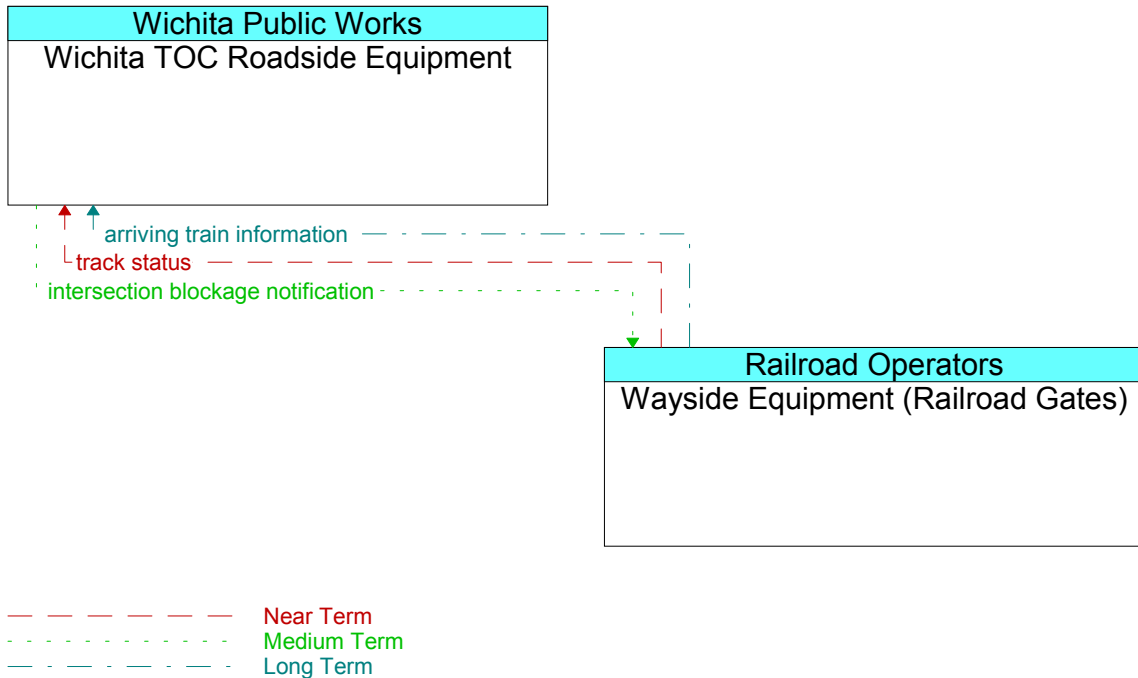
Existing

**Figure 66. Vehicle Communications Diagram**

For this diagram, the primary communication is between the Vehicle and the KTA Toll Collection Equipment. This is a wireless communication interface, involving toll information over a dedicated short range communications network. There are many other ITS applications that can communicate with the vehicle. As the VII initiative and DSRC 5.9GHz standards mature, it is expected that there will be additional communication between the roadside and the vehicle.

## 2.52 Wayside Equipment (Railroad Gates)

The following diagram (Figure 67) shows all interfaces in the regional ITS architecture surrounding the Wayside Equipment (Railroad Gates) element at Highway Rail Intersections (HRI) with annotated timeframes for expected communication content. The associated stakeholders are depicted on the top of each box containing an element.

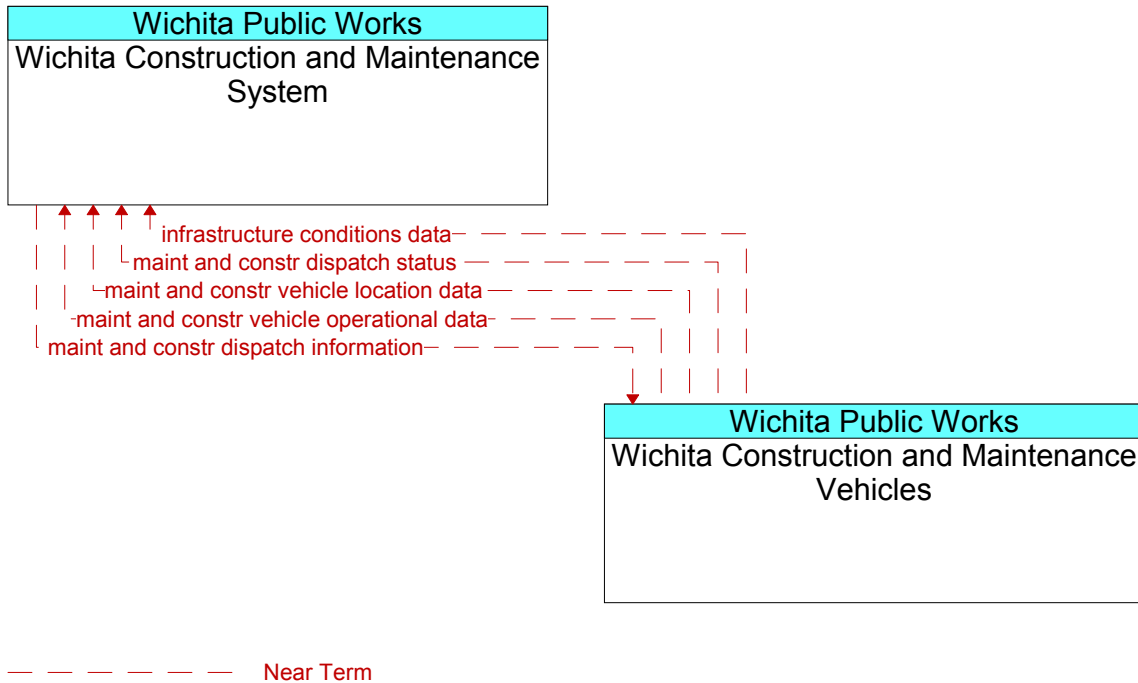


**Figure 67. Wayside Equipment (Railroad Gates) Communications Diagram**

The communications between the Wayside Equipment (Railroad Gates) and the Wichita Traffic Operations Center includes intersection blockage, track and train status (it is assumed that there are request flows for this information, they are not shown) information on either a wireless or point-to-point communications system.

### 2.53 Wichita Construction and Maintenance Vehicles

The following diagram (Figure 68) shows all interfaces in the regional ITS architecture surrounding the Wichita Construction and Maintenance Vehicles element with annotated timeframes for expected communication content. The associated stakeholders are depicted on the top of each box containing an element.



**Figure 68. Wichita Construction and Maintenance Vehicles Communications Diagram**

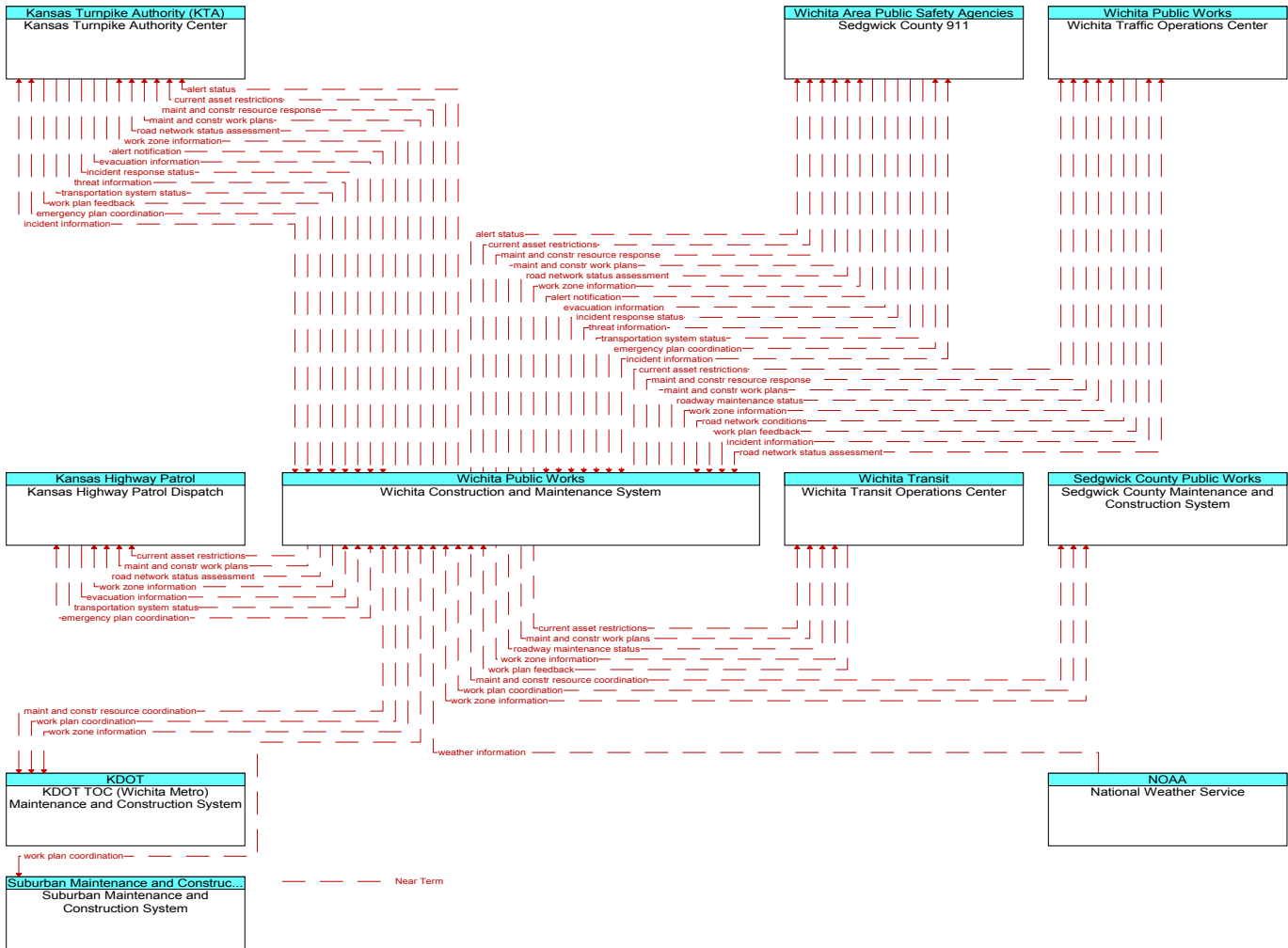
The communications between the Wichita Construction and Maintenance Vehicles and the City of Wichita Construction and Maintenance System includes maintenance and construction vehicle and dispatch (it is assumed that there are request flows for this information, they are not shown) information. This is a wireless communication interface, most likely using 800MHz data exchanges.

## 2.54 Wichita Construction and Maintenance System

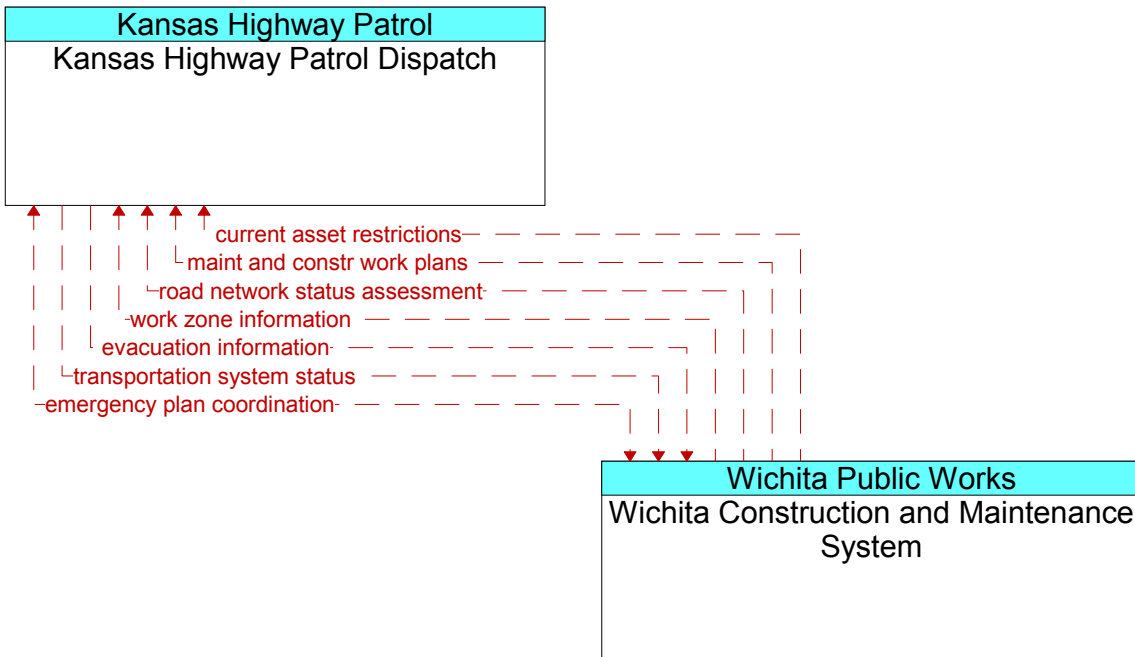
The following diagram (Figure 69, Figure 70 and Figure 71) shows all interfaces in the regional ITS architecture surrounding the Wichita Construction and Maintenance System element with annotated timeframes for expected communication content. The associated stakeholders are depicted on the top of each box containing an element.



# Wichita Area Regional ITS Architecture – Volume 3

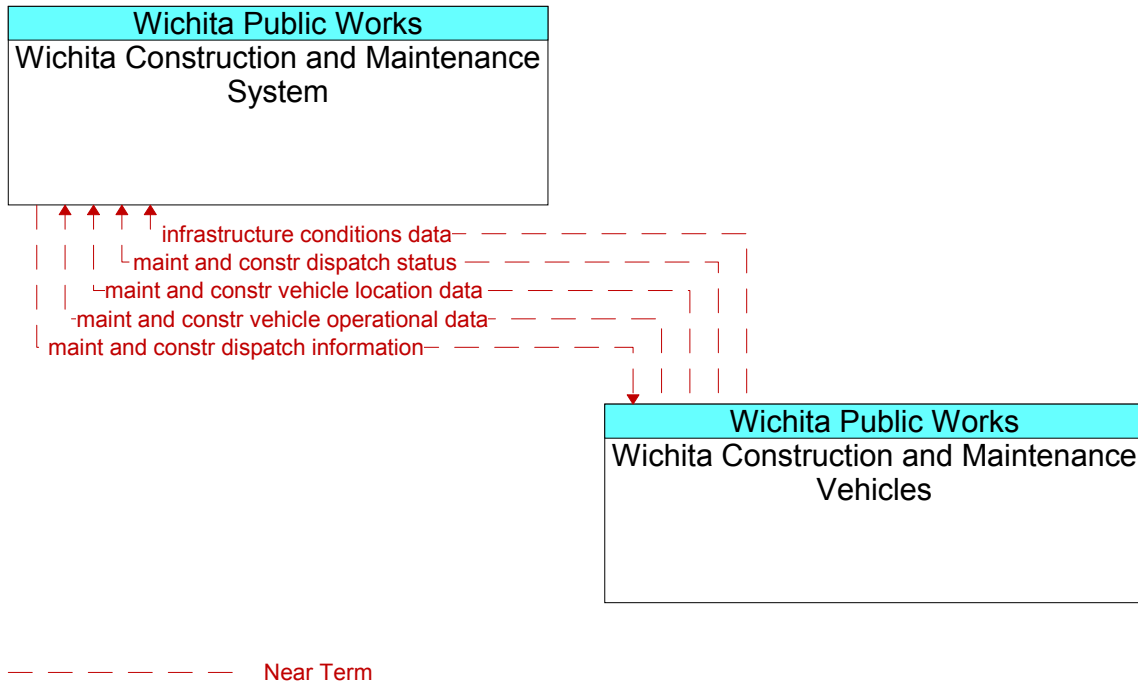


**Figure 69. Wichita Construction and Maintenance System Communications Diagram (Part 1)**



----- Near Term

**Figure 70. Wichita Construction and Maintenance System Communications Diagram (Part 2)**

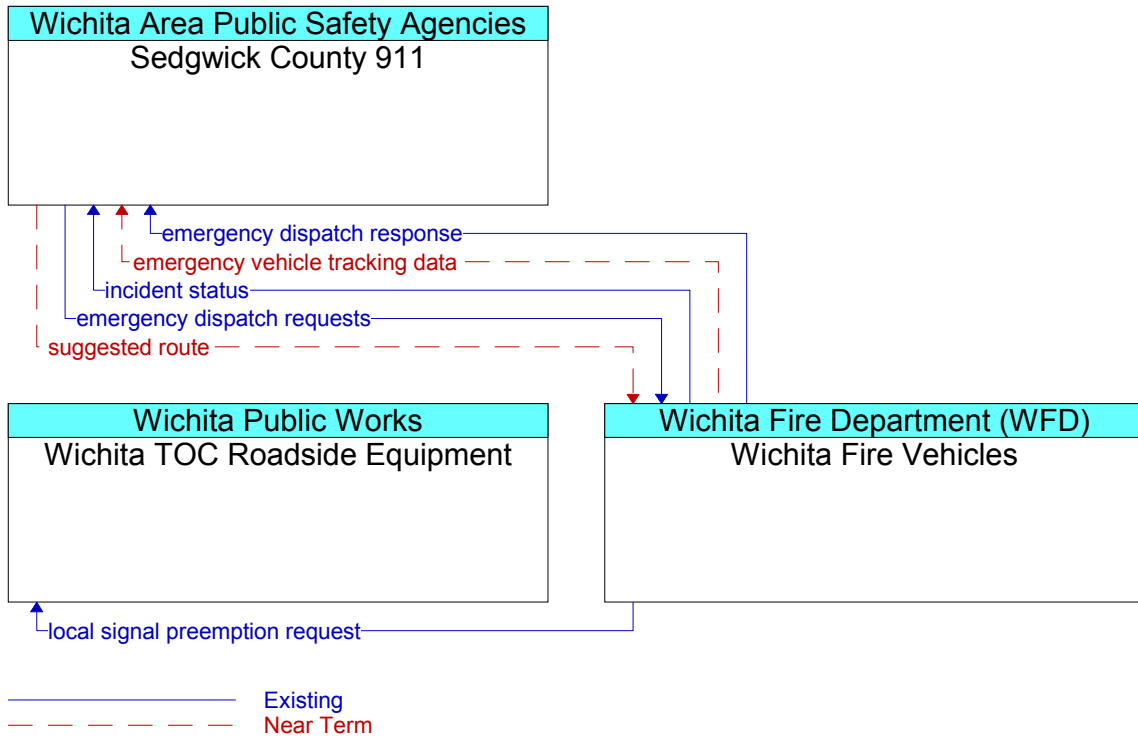


**Figure 71. Wichita Construction and Maintenance System Communications Diagram (Part 3)**

The communications between the Wichita Construction and Maintenance System and the various elements providing or requiring maintenance and construction information is largely a point-to-point communication interface, with wireless communication, most likely 800MHz radios, to and from the vehicles.

### 2.55 Wichita Fire Vehicles

The following diagram (Figure 72) shows all interfaces in the regional ITS architecture surrounding the Wichita Fire Vehicles element with annotated timeframes for expected communication content. The associated stakeholders are depicted on the top of each box containing an element.

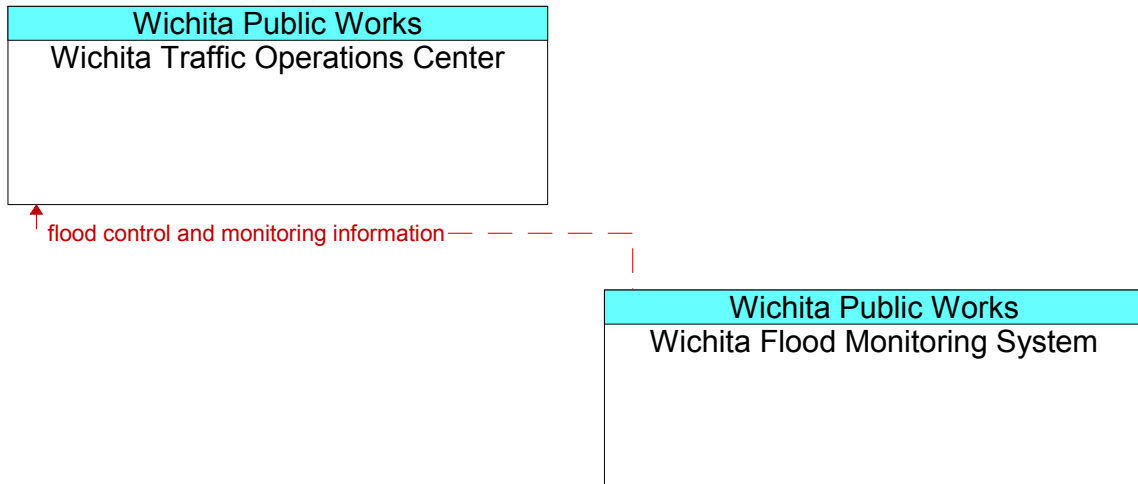


**Figure 72. Wichita Fire Vehicles Communications Diagram**

The communications between the Wichita Fire Vehicles and the Sedgwick County 911 system includes fire vehicle dispatch (it is assumed that there are request flows for this information, they are not shown) information and local signal preemption. The local signal preemption is a wireless communication interface using Opticom while the wireless communication between the fire vehicles and the 911 system is 800 MHz radios.

## 2.56 Wichita Flood Monitoring System

The following diagram (Figure 73) shows all interfaces in the regional ITS architecture surrounding the Wichita Flood Monitoring System element with annotated timeframes for expected communication content. The associated stakeholders are depicted on the top of each box containing an element.



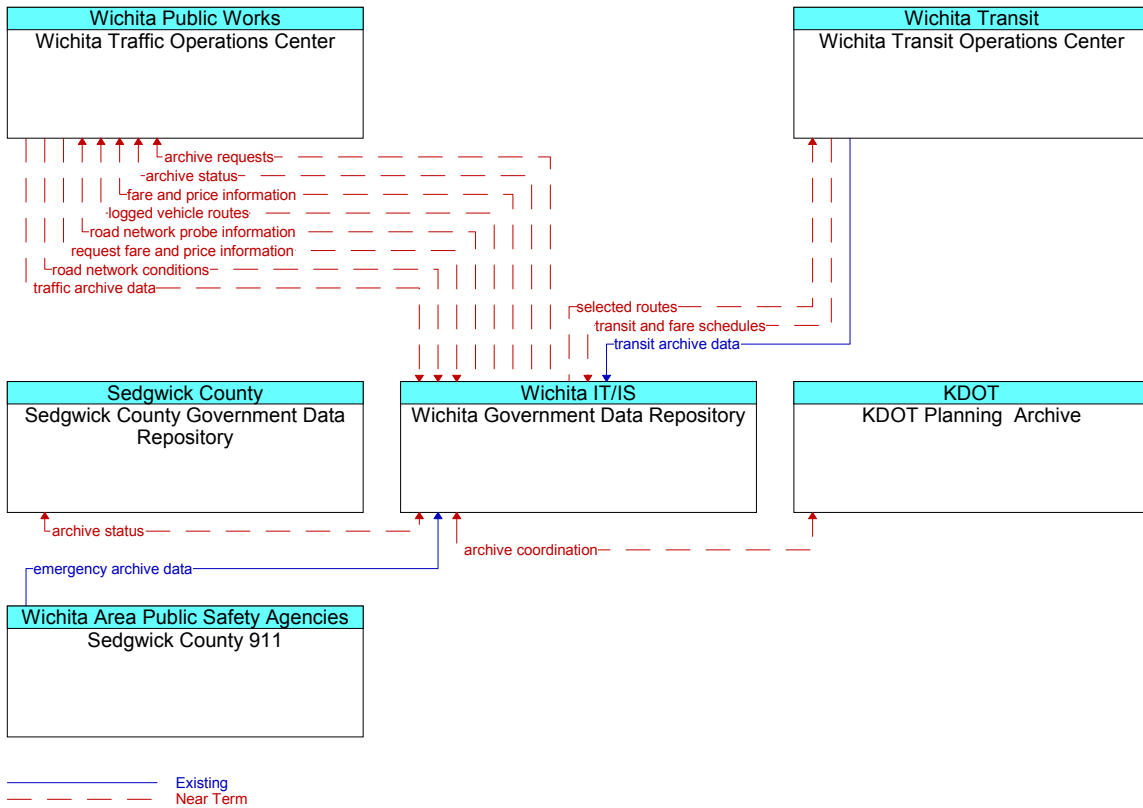
----- Near Term

**Figure 73. Wichita Flood Monitoring System Communications Diagram**

The communications between the Wichita Flood Monitoring System and the Wichita Traffic Operations Center involves flood control and monitoring (it is assumed that there are request flows for this information, they are not shown) information currently on a point-to-point communications system.

## **2.57 Wichita Government Data Repository**

The following diagram (Figure 74) shows all interfaces in the regional ITS architecture surrounding the City of Wichita Government Data Repository element with annotated timeframes for expected communication content. The associated stakeholders are depicted on the top of each box containing an element.

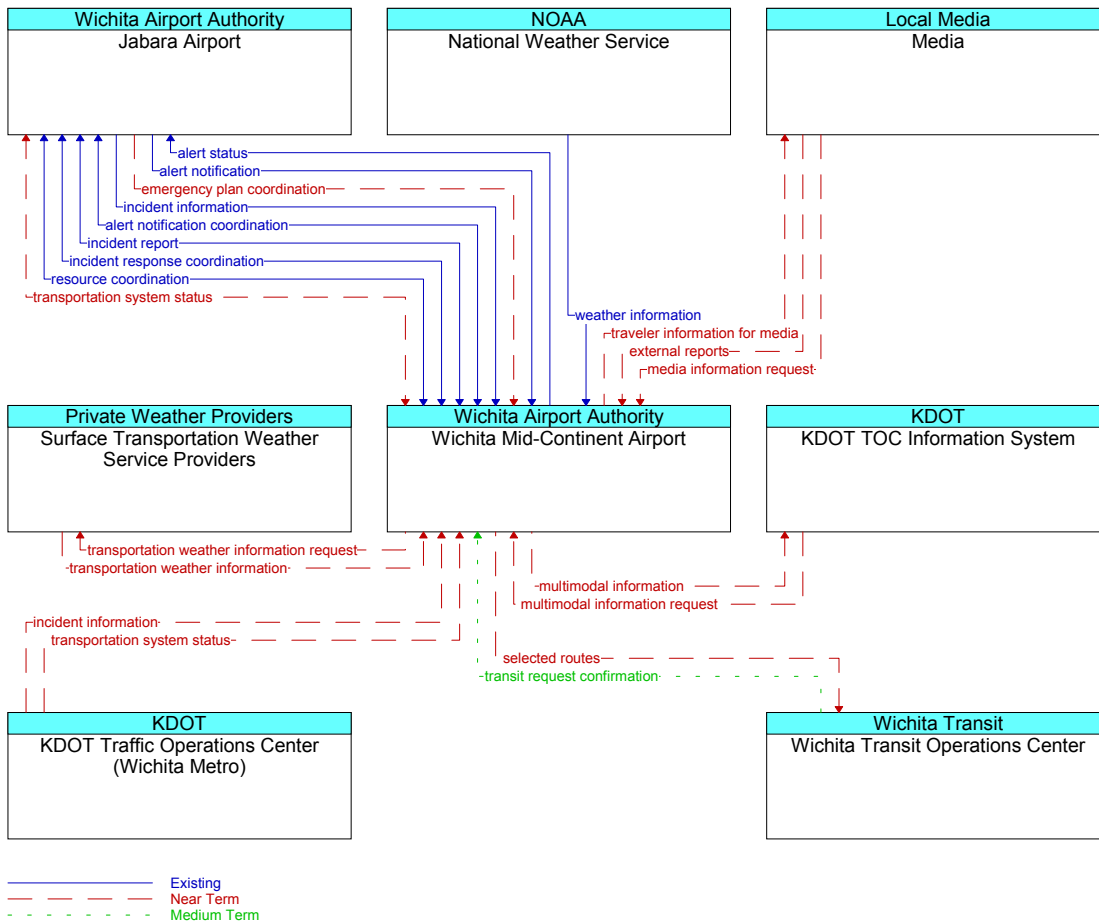


**Figure 74. Wichita Government Data Repository Communications Diagram**

The communications between the City of Wichita Government Data Repository and the Sedgwick County 911 center, KDOT Planning Archive, Wichita Government Data Repository, Wichita Transit Operations Center and the Wichita Traffic Operations Center includes the exchange of archive information between repositories and the archiving of the TOC and Transit Center data. This is a point-to-point communication interface, most likely, based on the large amount of information, using fiber.

### 2.58 Wichita Mid-Continent Airport

The following diagram (Figure 75) shows all interfaces in the regional ITS architecture surrounding the Wichita Mid-Continent Airport element with annotated timeframes for expected communication content. The associated stakeholders are depicted on the top of each box containing an element.

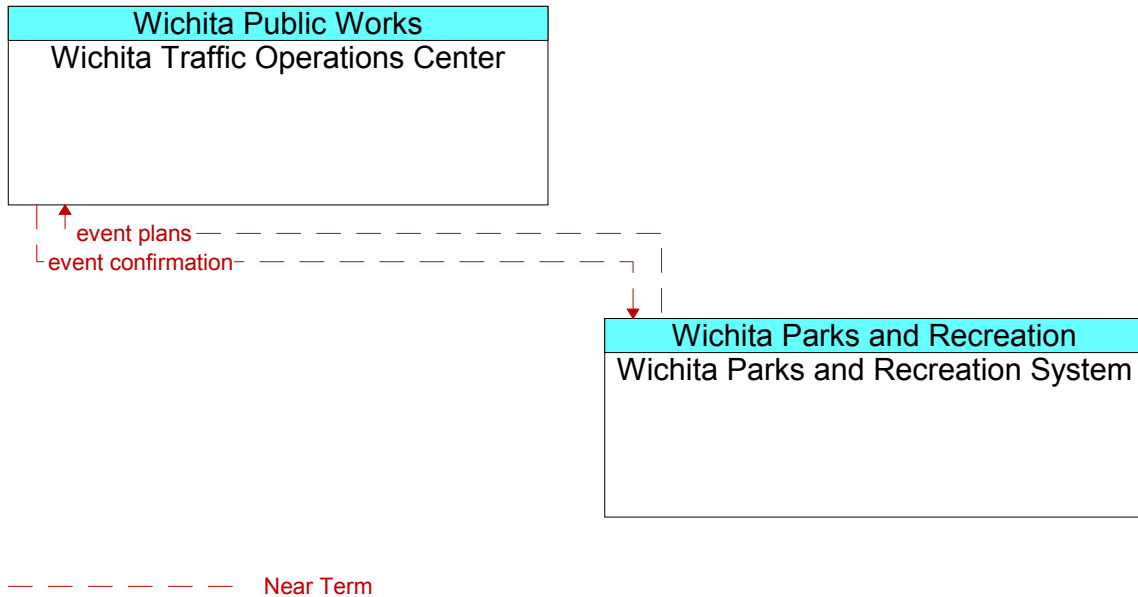


**Figure 75. Wichita Mid-Continent Airport Communications Diagram**

The communications between the Wichita Mid-Continent Airport and the Wichita Transit Operations Center, Jabara Airport and the National Weather Service includes the exchange of information on a point-to-point communication interface. The communications between the Wichita Mid-Continent Airport and the Wichita Mid-Continent Airport Public Safety Vehicles is a wireless interface most likely over 800MHz radios.

## 2.59 Wichita Parks and Recreation System

The following diagram (Figure 76) shows all interfaces in the regional ITS architecture surrounding the Wichita Parks and Recreation System element with annotated timeframes for expected communication content. The associated stakeholders are depicted on the top of each box containing an element.



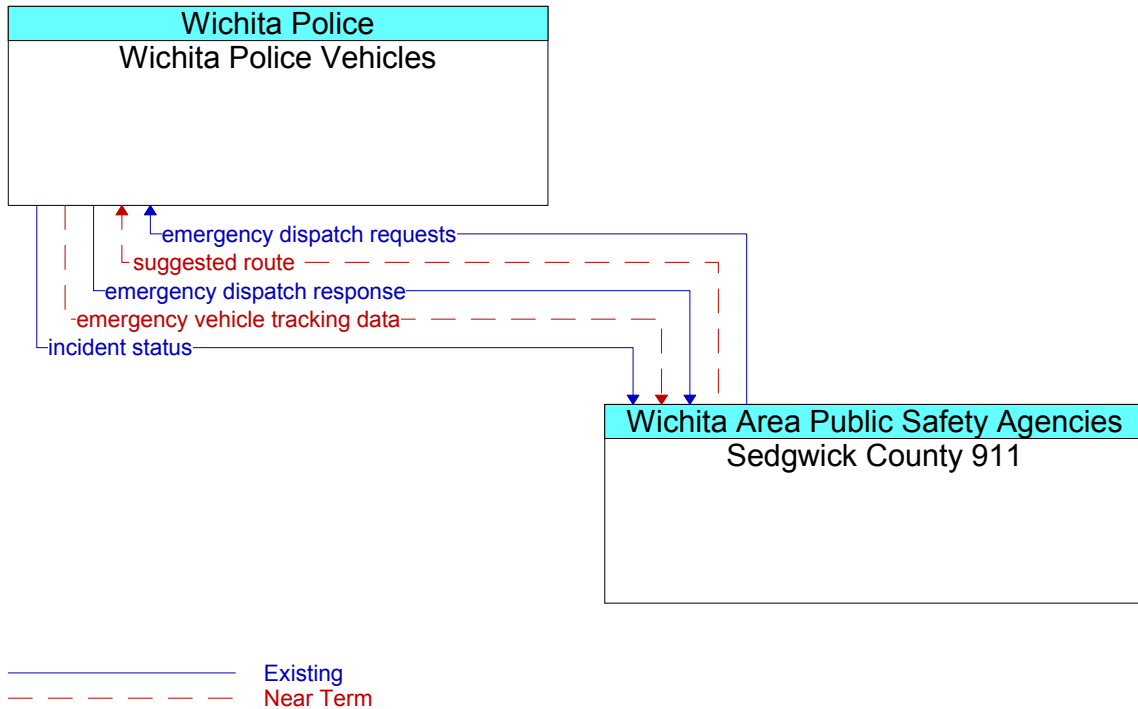
**Figure 76. Wichita Parks and Recreation System Communications Diagram**

The communications between the Wichita Parks and Recreation System and the Wichita Traffic Operations Center includes the exchange of event information. This is a point-to-point communication interface.

## 2.60 Wichita Police Vehicles

The following diagram (Figure 77) shows all interfaces in the regional ITS architecture surrounding the Wichita Police Vehicles element with annotated timeframes for expected communication content. The associated stakeholders are depicted on the top of each box containing an element.



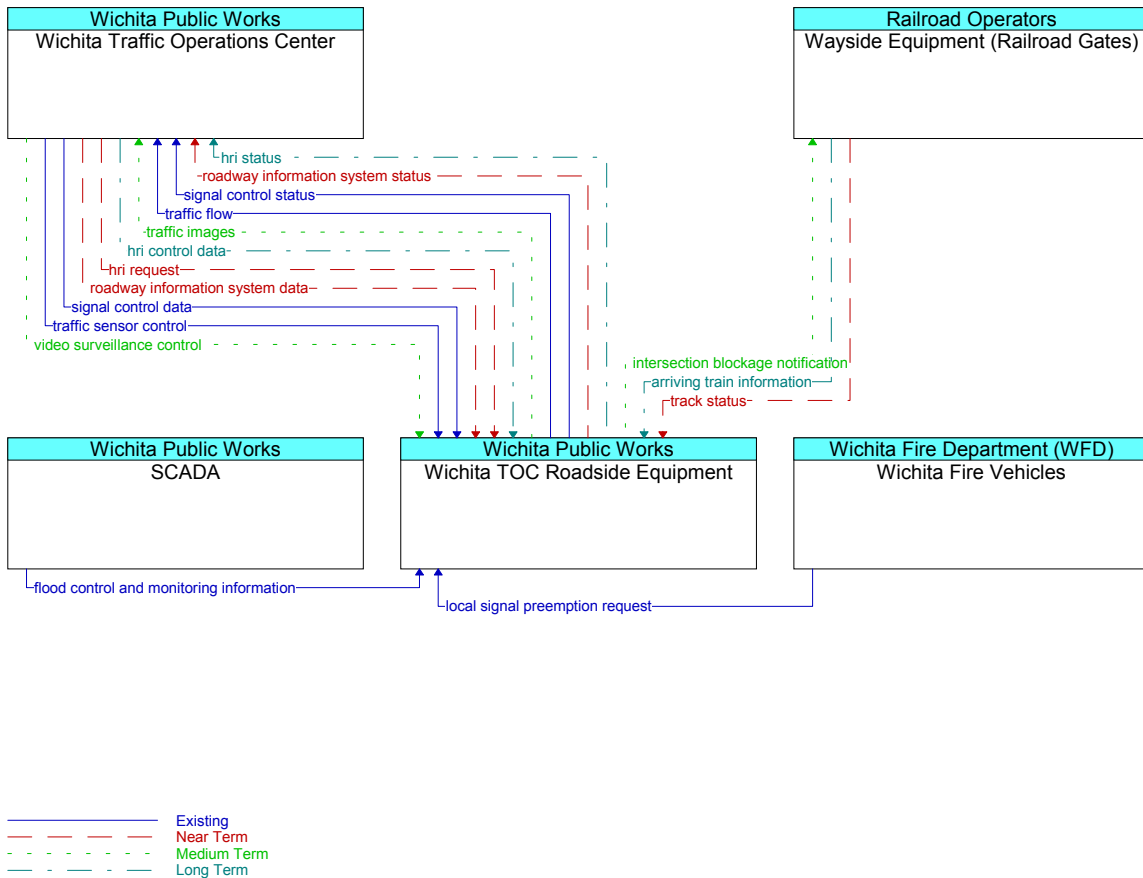


**Figure 77. Wichita Police Vehicles Communications Diagram**

The communications between the Wichita Police Vehicles and the Sedgwick County 911 dispatch (it is assumed that there are request flows for this information, they are not shown) information. These interfaces are a wireless communication interface over 800 MHz radios.

## 2.61 Wichita TOC Roadside Equipment

The following diagram (Figure 78) shows all interfaces in the regional ITS architecture surrounding the Wichita TOC Roadside Equipment element with annotated timeframes for expected communication content. The associated stakeholders are depicted on the top of each box containing an element.



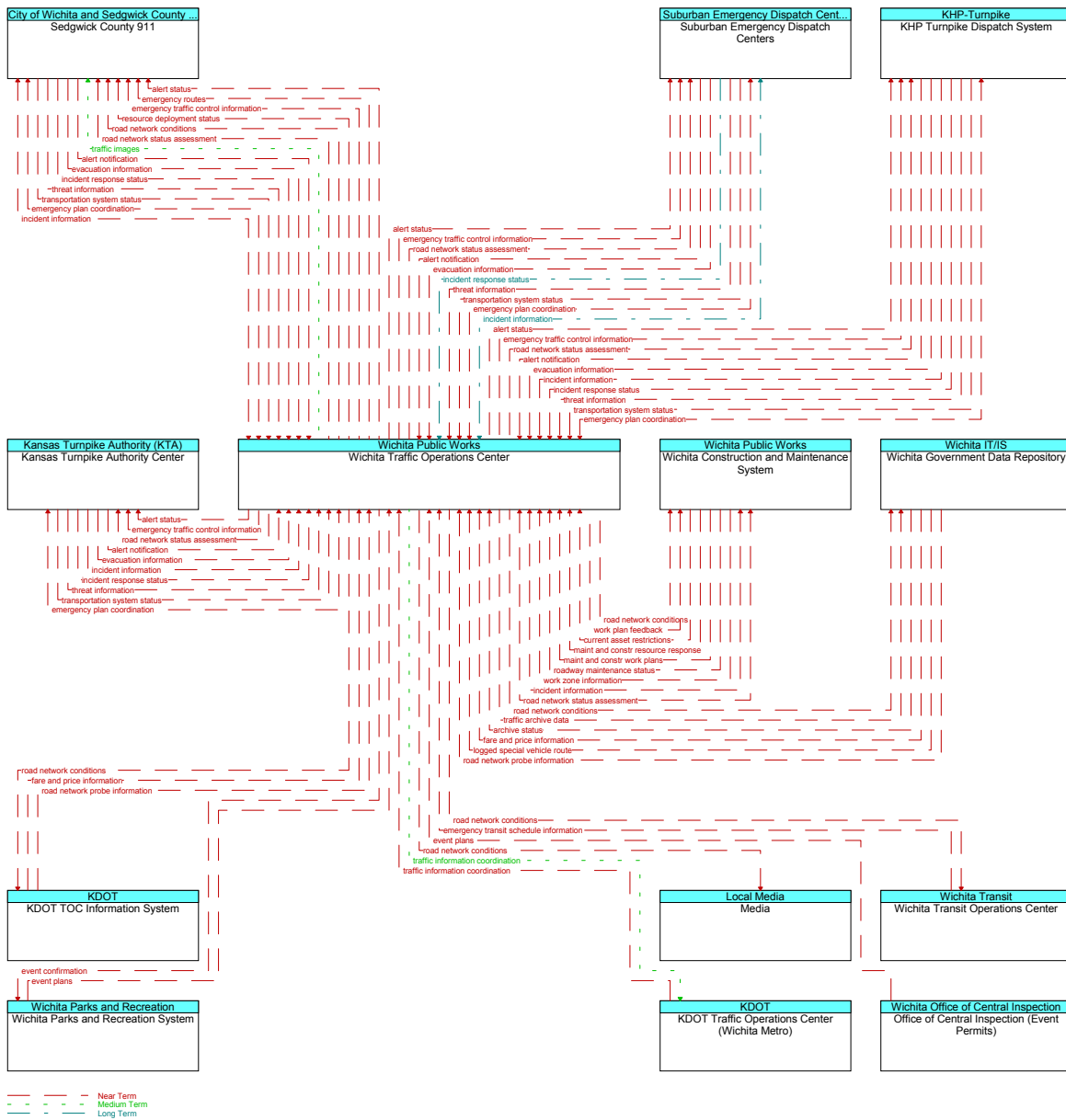
**Figure 78. Wichita TOC Roadside Equipment Diagram**

The communications between the Wichita TOC Roadside Equipment and the Wichita Traffic operations Center includes signal control and traffic flow (it is assumed that there are request flows for this information, they are not shown) information as well as flood control and monitoring information, local signal preemption requests from Wichita Fire. The signal control study should further define the specific signal control communications needs. The flood monitoring and wayside equipment would be point-to-point communication with the local signal preemption being a wireless communication interface using Opticom.

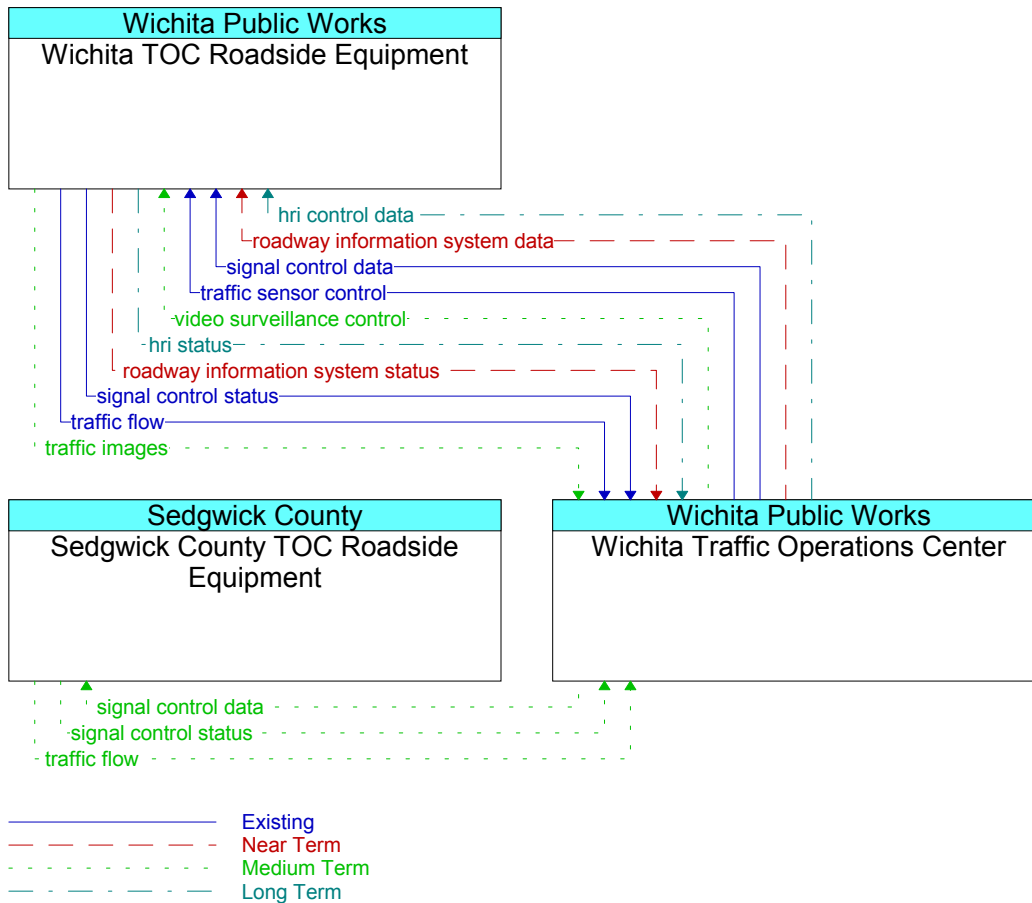
## 2.62 Wichita Traffic Operations Center

The following diagram (Figure 79) shows all interfaces in the regional ITS architecture surrounding the Wichita Traffic Operations Center (TOC) element with annotated timeframes for expected communication content. The associated stakeholders are depicted on the top of each box containing an element.

# Wichita Area Regional ITS Architecture – Volume 3



**Figure 79. Wichita Traffic Operations Center (TOC) Communications Diagram (Part 1)**

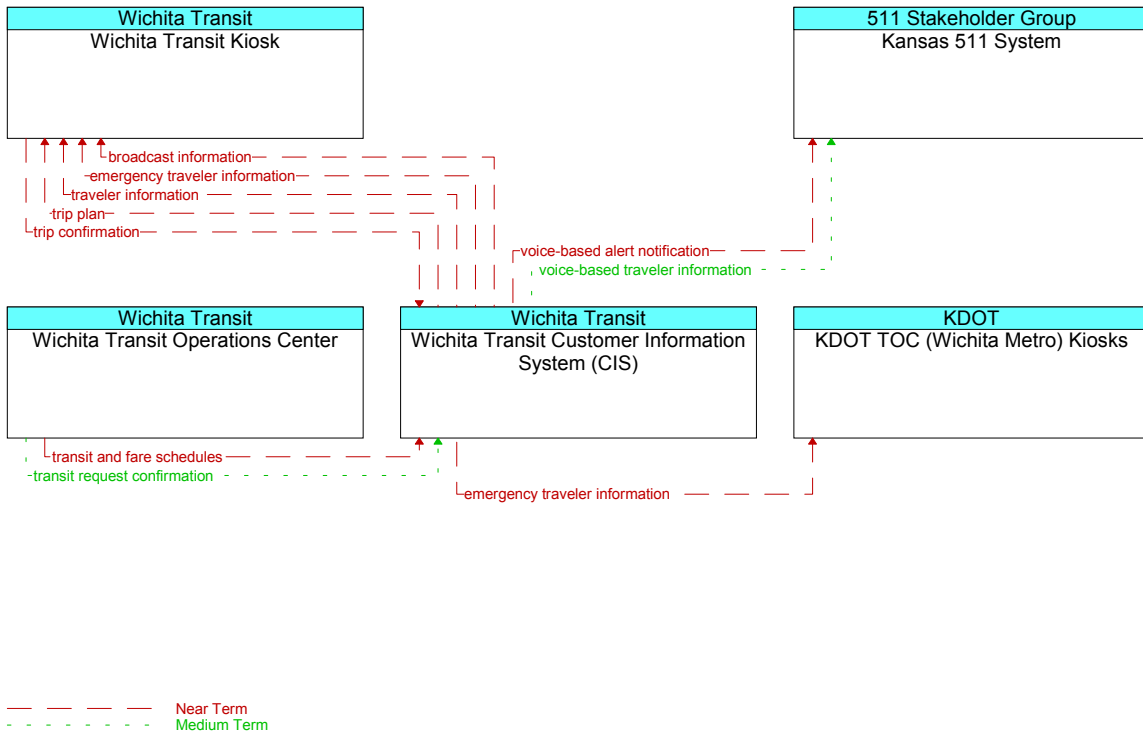


**Figure 80. Wichita Traffic Operations Center (TOC) Communications Diagram (Part 2)**

The communications between the Wichita Traffic Operations Center (TOC) and the other significant elements includes signal control and traffic flow (it is assumed that there are request flows for this information, they are not shown) information for the City of Wichita and in the future Sedgwick County. The signal control study should further define the specific signal control communications needs. The Wichita TOC has primarily point-to-point communications with many of the other elements in the region and it is expected that fiber will be used extensively.

### 2.63 Wichita Transit Customer Information System (CIS)

The following diagram (Figure 81) shows all interfaces in the regional ITS architecture surrounding the Wichita Transit Customer Information System (CIS) element with annotated timeframes for expected communication content. The associated stakeholders are depicted on the top of each box containing an element.

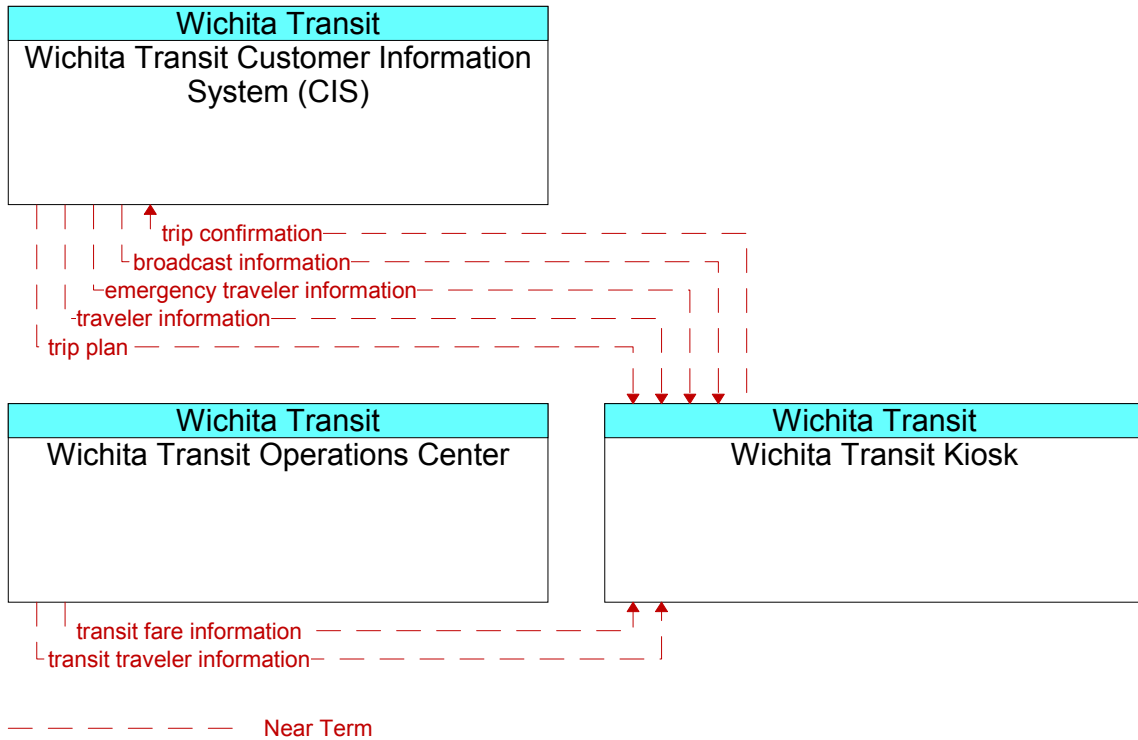


**Figure 81. Wichita Transit Customer Information System (CIS) Communications Diagram**

The Wichita Transit Customer Information System (CIS) obtains its information primarily from the Wichita Transit Operations Center and the information is disseminated to kiosks and the Kansas 511 System on a point-to-point communication interface.

## 2.64 Wichita Transit Kiosk

The following diagram (Figure 82) shows all interfaces in the regional ITS architecture surrounding the Wichita Transit Kiosk element with annotated timeframes for expected communication content. The associated stakeholders are depicted on the top of each box containing an element.



**Figure 82. Wichita Transit Kiosk Communications Diagram**

The Wichita Transit Kiosk obtains its information primarily from the Wichita Transit Operations Center and the Wichita Transit Customer Information System in a point-to-point manner.

### 2.65 Wichita Transit Operations Center

The following diagrams (Figure 83, Figure 84, Figure 85, and Figure 86) show all interfaces in the regional ITS architecture surrounding the Wichita Transit Operations Center (TOC) element with annotated timeframes for expected communication content. The associated stakeholders are depicted on the top of each box containing an element.

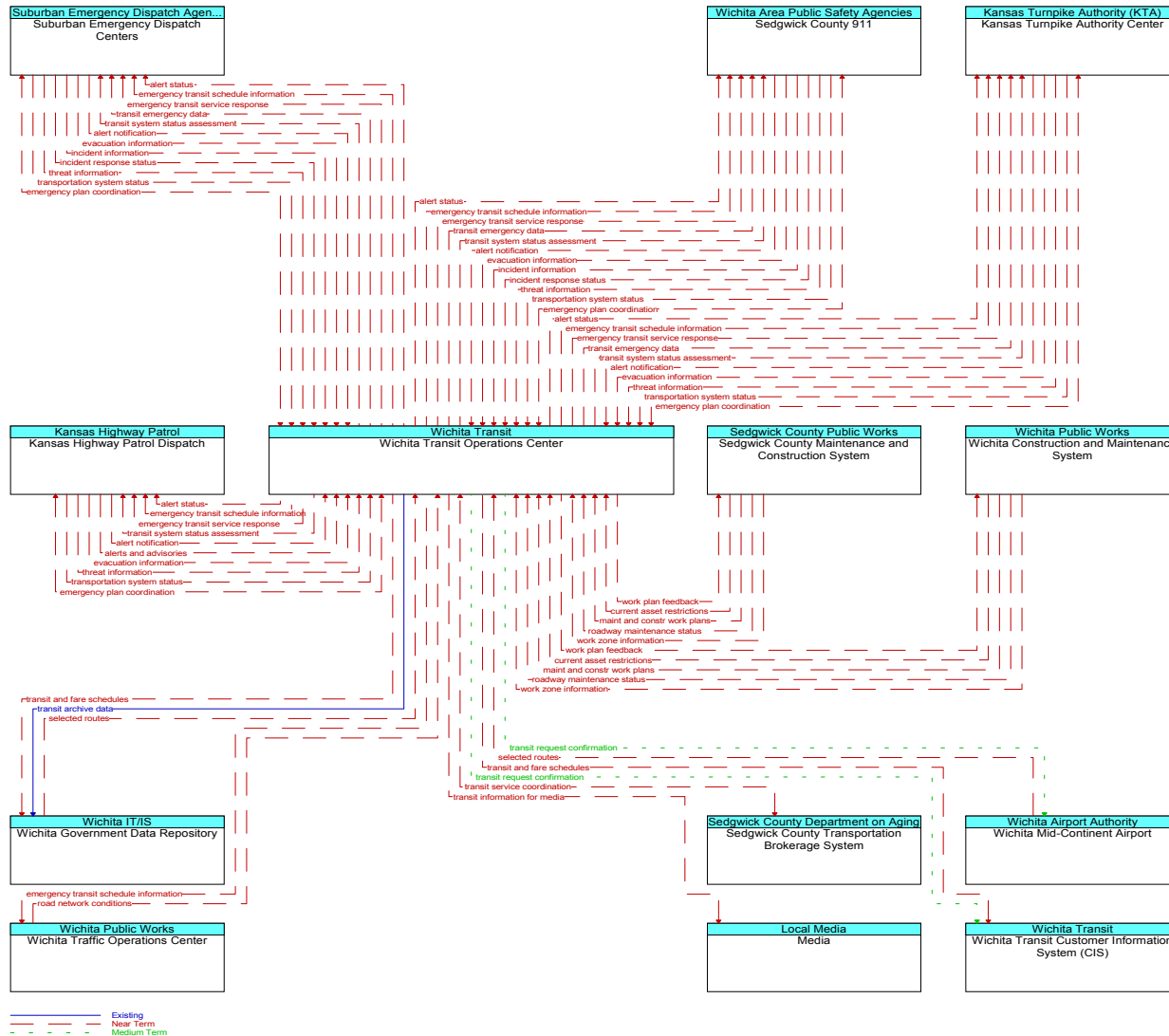
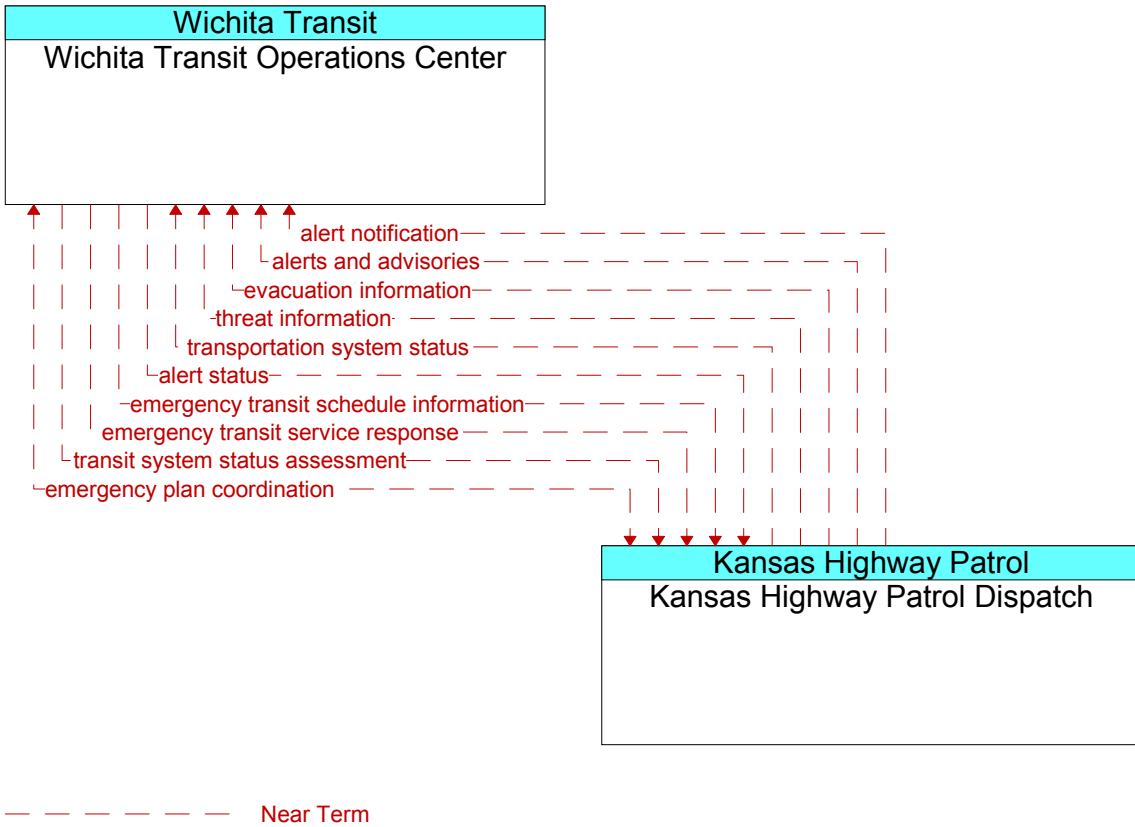
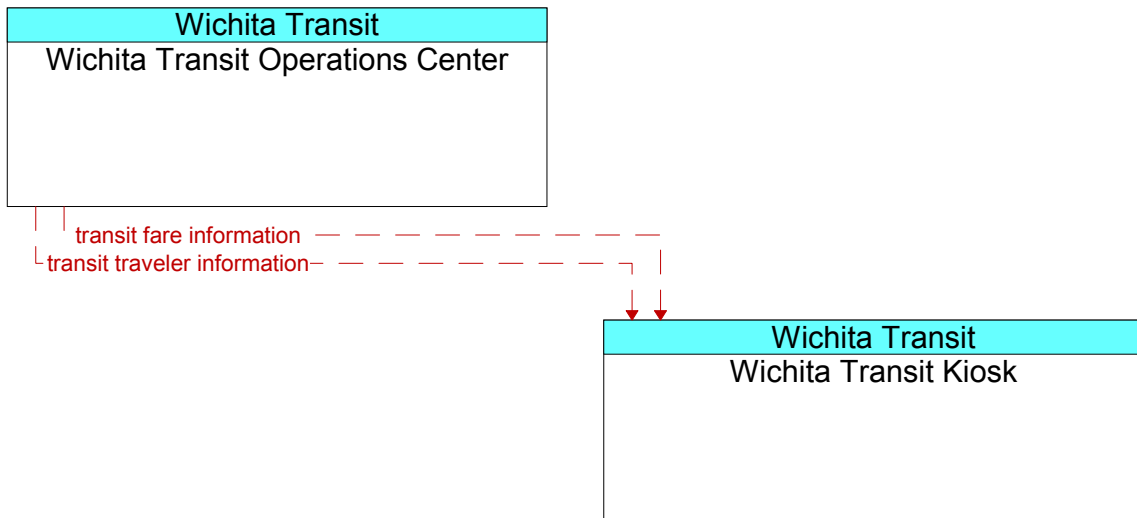


Figure 83. Wichita Transit Operations Center Communications Diagram (Part 1)



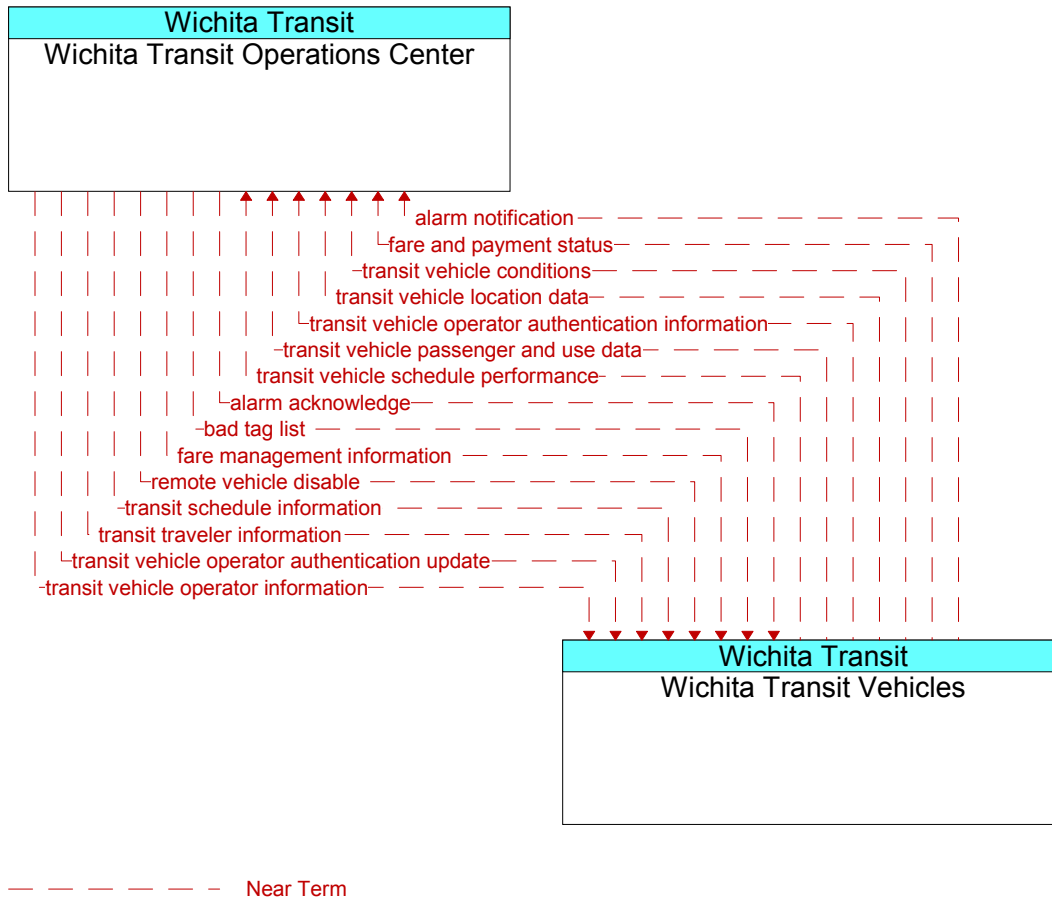
**Figure 84. Wichita Transit Operations Center Communications Diagram (Part 2)**





----- Near Term

**Figure 85. Wichita Transit Operations Center Communications Diagram (Part 3)**

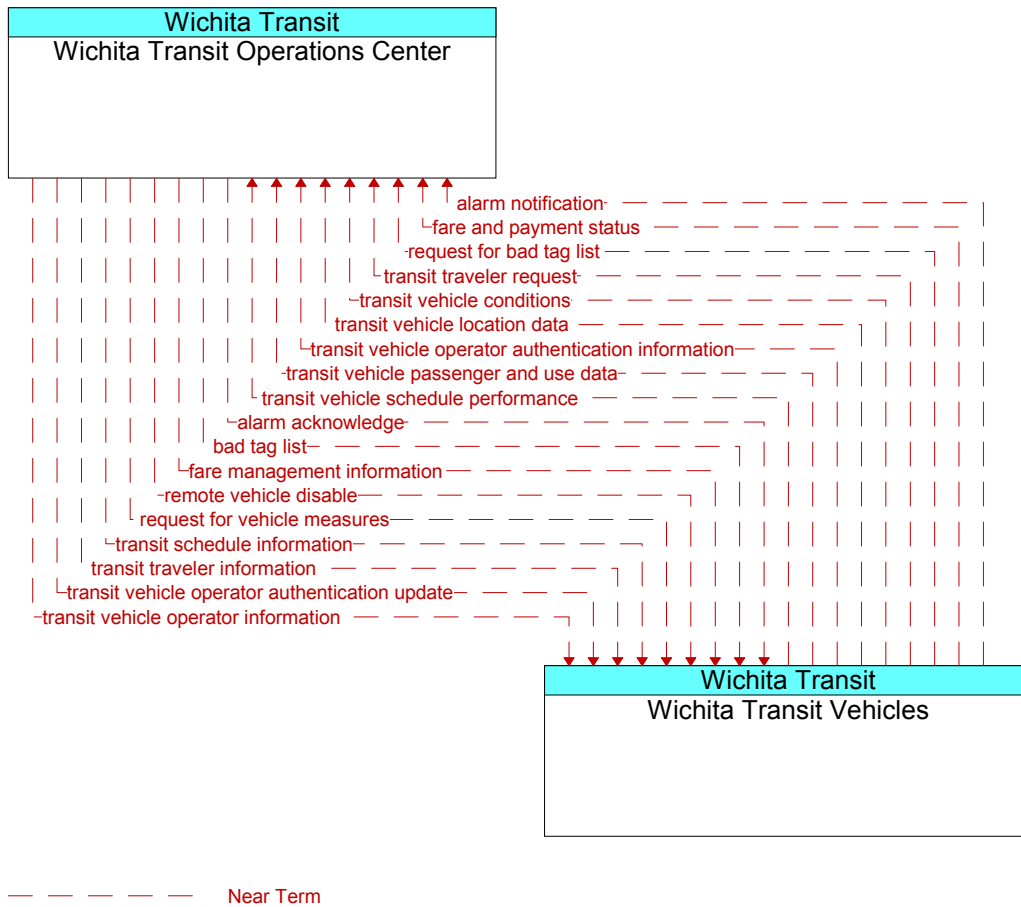


**Figure 86. Wichita Transit Operations Center Communications Diagram (Part 4)**

The Wichita Transit Operations Center obtains its information from a myriad of sources and the information is disseminated to kiosks and the most elements in the Wichita-Sedgwick County region on a point-to-point communication interface. In addition, the Wichita Transit Operations Center plans to communicate wirelessly with the fleet of Transit Vehicles.

### 2.66 Wichita Transit Vehicles

The following diagram (Figure 87) shows all interfaces in the regional ITS architecture surrounding the Wichita Transit Vehicles element with annotated timeframes for expected communication content. The associated stakeholders are depicted on the top of each box containing an element.



**Figure 87. Wichita Transit Vehicles Communications Diagram**

The communications between the Wichita Transit Vehicles and the Wichita Transit Operations Center includes a robust set of messages including vehicle, emergency, and scheduling (it is assumed that there are request flows for this information, they are not shown) information. These interfaces are a wireless communication interface most likely over 800 MHz radios.

### 3 Existing Regional Communications Infrastructure

The existing infrastructure for City, County and State agencies involved in the ITS project is comprised of both wired and wireless components. Currently only a limited number of agencies are actively utilizing wireless mobile data, so as a result most of the existing infrastructure is in the form of wired connectivity including LAN, WAN and telecom in the form of fiber, leased lines, or twisted pair.

#### 3.1 Cabled Solutions

**KANWIN.** The KANsas Wide area Information Network (KANWIN) is a statewide data communications network supporting the TCP/IP, IPX and SNA protocols. KANWIN is a collection of circuits, routers and other communications equipment that enable computers and people to exchange data across the state of Kansas and the world using the TCP/IP, IPX and SNA protocols. KANWIN supports point-to-point (dedicated) and frame relay connections from 56KB to 1.54MB speeds and dial-up access up to 28.8KB. KANWIN is managed by the Division of Information Systems and Communications (DISC). KANWIN is in addition to the existing SNA network and eventually will replace the SNA network for all SNA traffic in addition to the other protocols. Note that the SNA protocol will not be replaced; it will simply be carried by a different physical network. Likewise, KANWIN will replace the ISN for dial-up services. Eventually KANWIN will be incorporated in every county throughout Kansas.

**KDOT.** The Kansas Department of Department of Transportation has leveraged opportunities to install fiber and conduit along major roadways. There are currently twelve strands of dark fiber (in two 1 ¼ inch conduits) that are installed along I-135, the major north-south interstate that runs through Wichita to the K-15 interchange. South of this interchange, there is a single conduit that has been run along K-15 to US-77 down to the Oklahoma border. KDOT has lit two of the 12 dark fibers from Wichita north to Salina. Equipment in Wichita is at I-135 and Central Ave. LightCore's fiber is lit on that whole route into Oklahoma and north into Salina.

The existing fiber bandwidth includes two OC-3's, with plans to upgrade to OC-12 by 2009. There are plans to build a ring that would provide path redundancy and diversity. Currently the fiber is designated for use by state government agencies (Legislative, Executive and Judicial branch) only; however negotiations are underway to allow usage by other agencies as a part of the Public Safety or ITS initiative. The fiber and conduit runs are shown on the following map illustration.

**Figure 88. KDOT Fiber and Conduit Routes**

**Twisted Pair.** The City of Wichita Signal Systems group is currently using twisted pair, with cable run throughout part of the city. This infrastructure, although widely deployed, provides little bandwidth and minimal benefit outside of its intended use. A study is underway to identify deficiencies in the current system, including the communications (fiber, wireless) infrastructure.

### 3.2 Wireless Solutions

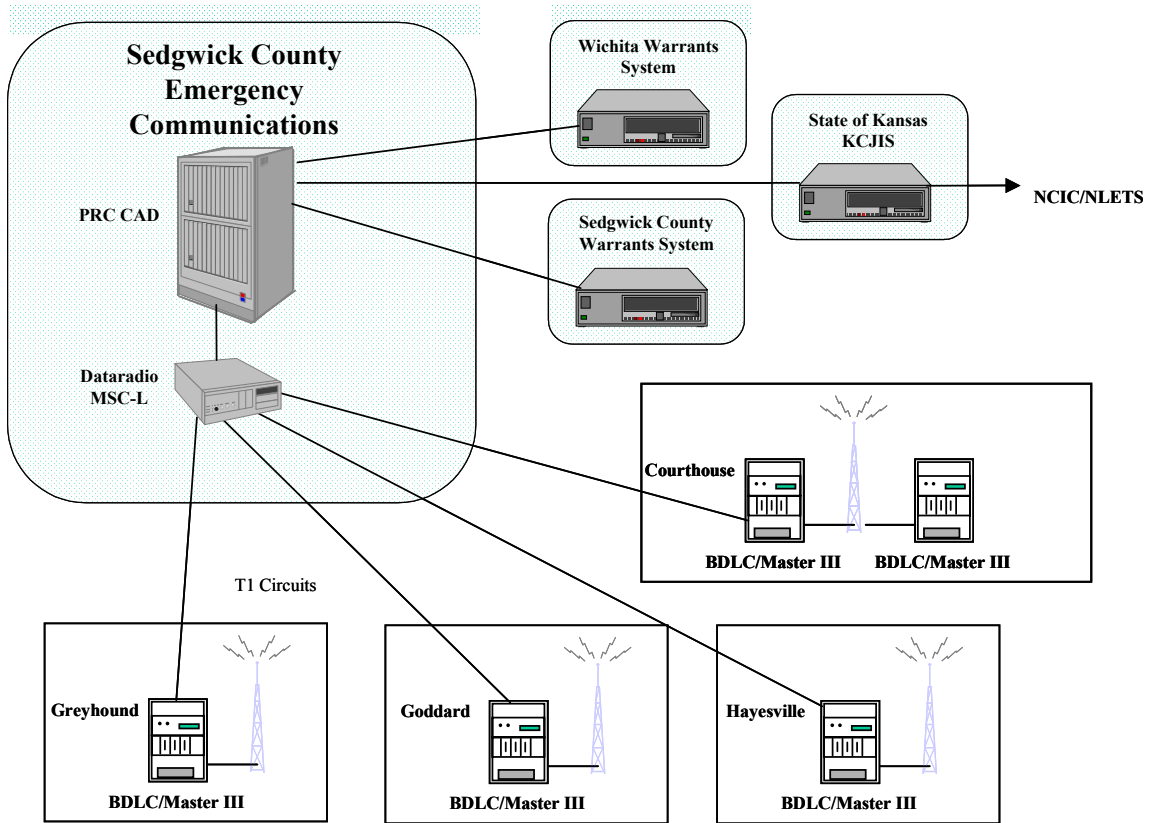
#### Dataradio Wireless Infrastructure

The most prevalent wireless solution to provide support for the City/County is in the form of the existing Dataradio wireless network, which provides extensive coverage throughout the County, although bandwidth is limited to 9.6 Kbps on each of the five channels. The current mobile data system is a private licensed system operated by Sedgwick County Emergency Communications and used by various public safety agencies. The radio infrastructure is described in the following paragraphs.

**Dataradio Infrastructure.** There is a Base Station Data Link Controller (BDLC) and a General Electric Master III base station at each of three base station sites in the County, and one site at the County Courthouse that has two BDLCs and two Master III base stations. The five BDLCs connect over leased T1 circuits with a Multi-Site Controller for LAN (MSC-L) located at the Sedgwick County Emergency Communications facility. The base station site information is shown in the table below.

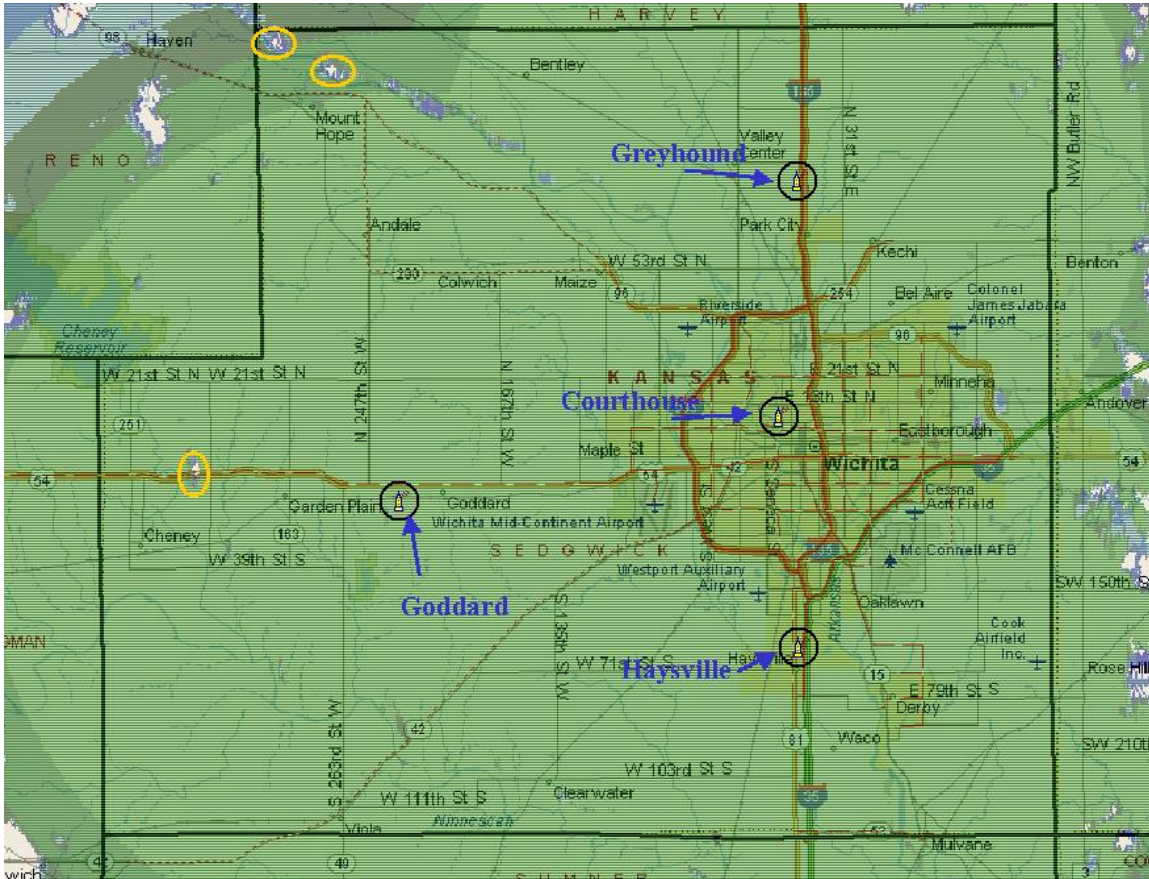
Site	Base Stations	Ownership	Latitude	Longitude	Antenna Height	Frequency
Courthouse	2	County	37:41:39.0	97:20:19.2	56 meters	a) 856.2125 b) 857.2125
Greyhound	1	County	37:49:32.0	97:19:32.2	107 meters	855.9625
Goddard	1	Leased	37:38:51.1	97:36:23.2	137 meters	854.9875
Haysville	1	Leased	37:33:58.1	97:19:29.2	130 meters	855.7375

The following diagram provides a logical depiction of the mobile data system infrastructure.



**Figure 89. Mobile Data System**

**System Coverage.** System coverage is provided by base stations at four locations including Goddard, Greyhound (Park City), Haysville and the County Courthouse. The map is shown in Figure 90. Coverage Prediction is annotated to clarify base station site locations and areas where coverage problems were predicted. The current system is predicted to provide close to 100% area coverage.



**Figure 90. Coverage Prediction**

**Dataradio System Upgrade.** The current system is in the process of being upgraded for operation with higher capacity through higher wireless data transmission speed. Dataradio offers an upgrade path using its parallel decode technology that can provide data transmission speeds of 43,200 bps. Operation at 43,200 bps may result in some degradation of system coverage, but this degradation should not be significant, although coverage outside of the County may be somewhat reduced.

Dataradio supports concurrent operation of older 9,600 bps mobile equipment and higher speed replacement equipment. This will allow existing mobile equipment to be used to its maximum life span and replaced slowly over time. In addition, Dataradio will support an initial partial migration for City users by migrating one channel from the County Courthouse to a higher data speed, replacing the Master III base station with a new Paragon PD (Parallel Decode) base station, and migrating mobile units to this channel using Gemini PD mobile data radio modems as equipment is replaced over time. Eventually as City users are migrated to the higher speed technology, the remaining Courthouse channel will be configured to exclusive higher speed operation. Eventually, when all City and County units have upgraded mobile equipment, the remaining system base stations will be configured for exclusive higher speed operation.



One additional antenna for receive-only purposes would also need to be added to each base station site. Mobile equipment will be upgraded to Dataradio GeminiPD integrated radio modems and diversity reception antenna systems consisting of two antennas instead of only one.

### 3.3 Application Infrastructure Relationship

The ability to implement various applications is dependent on the bandwidth that is available. The following table provides guidance as to the bandwidth requirements associated with these applications. The total bandwidth will be dependent on the number of users, number of messages, and size of messages. As the number of users and the number of messages increase, additional channels can be added at the same (or greater) bandwidth to accommodate the additional bandwidth requirements.

<b>Application</b>	<b>Bandwidth Requirement</b>
Text messaging, chat, e-mail (no attachments) Dispatch, status messages NCIC/NLETS queries AVL (limited refresh) Database queries (canned) Traffic signal controllers Ramp meters, traffic detectors Dynamic message signs Highway Advisory Radio	4.8 – 19.2 Kbps
E-mail (with limited attachments) Intranet Internet	40 – 60 Kbps
Voice over IP (16 Kbps per user)	100 – 300 Kbps
Video streaming (15 Frames/sec, 320x240 pixels, 10/1 compression), Traffic cameras	1.5 Mbps
MPEG-4 video	0.2 – 1.5 Mbps
MPEG-2 video	1.5 – 3 Mbps
Analog video	6 Mbps

Note: Video requirements vary significantly with the size of the image, color or black & white, refresh rate, resolution, compression techniques and other factors.

### 3.4 Comparative Analysis

In order to compare mobile the various data networks, the relative strengths and weaknesses of each alternative will be evaluated to determine the best wireless infrastructure alternatives to meet agency needs.

The Iteris team considered and rated the following factors for the alternatives comparative analysis.

- ◆ Coverage
- ◆ AVL Suitability
- ◆ Textual Messaging Suitability
- ◆ General Mobile Data Suitability
- ◆ Reliability
- ◆ Portable Device Support
- ◆ Cost Initially
- ◆ Cost Over Time

### **Coverage**

Coverage for vehicle based equipment throughout the City and County is considered critical. Coverage for portable devices is rated under the Portable Device Support factor.

### **AVL Suitability**

The AVL Suitability of an alternative was rated based on the relative strength of the alternative technology to support the AVL traffic for the user agencies compared to other alternatives.

### **Textual Messaging Suitability**

The Textual Messaging Suitability of an alternative was rated based on the relative strength of the alternative technology to support the textual messaging traffic for the user agencies compared to other alternatives. Textual messaging includes dispatch and status reporting, textual database inquiry, and e-mail without attachments or chat type messaging.

### **General Mobile Data Suitability**

The General Mobile Data Suitability of an alternative was rated based on the relative strength of the alternative technology to support the general mobile data traffic for the user agencies compared to other alternatives. General mobile data includes client/server and large file transfer applications.

### **Reliability**

Reliability is considered critical to users. Reliability was rated based on the expected ability of the alternative to be available for users 7 days per week and 24 hours per day. While no alternative can be expected to provide 100% availability, each alternative was rated based on the Iteris team's experience with the alternative.

**Portable Device Support**

Portable Device Support was rated based on whether the alternative supports portable devices and coverage for mobile data communications. The Iteris Team considers availability of PC Card wireless modems to be optimal since it allows unrestricted selection of portable computing devices.

**Cost Initially**

Cost Initially was rated based on the relative first year cost of an alternative compared to all other alternatives. The lowest cost alternative receives the highest rating and others are rated proportionally less based on its relative cost compared to the lowest cost alternative.

**Cost Over Time**

Cost Over Time was rated based on the relative cumulative cost of an alternative at year 7 compared to all other alternatives. The lowest cost alternative receives the highest rating and others are rated proportionally less based on its relative cost compared to the lowest cost alternative.

**Operating Cost**

Operating Cost was rated based on the relative annual cost for operating an alternative compared to all other alternatives. The lowest cost alternative receives the highest rating and others are rated proportionally less based on its relative cost compared to the lowest cost alternative.

## **4 Planned Communications Resources**

As previously described, the County is in the process of upgrading the existing Dataradio wireless network. In addition, the following initiatives are either underway or available resources.

### **4.1 Cabled Solutions**

Although new wireless technology solutions are available that may allow for replacement of some cabled solutions, the predominance of existing wired infrastructure, along with the increased reliability of hard-wired solutions, means that there will be a continued dependence on twisted pair, coax and fiber. As previously discussed, twisted pair cable offers only a limited bandwidth, but it is adequate for most ITS applications. The cabling is inexpensive and reliable, and it is more cost-effective to use existing wireline solutions than to replace them. The same is true for coax, which is resistant to interference and provides a reliable way to transfer large amounts of data such as traffic camera video. Wired solutions will continue to play a role in ITS projects for the foreseeable future.

The growing fiber backbone that KDOT is installing (both dark and lit fiber), including conduit, allows for additional use of fiber at minimal cost. This network provides a substantial wired infrastructure that can handle the data requirements for all of the projects currently identified. Additional runs will be required if there is no infrastructure in place, but this can be dealt with on a case-by-case basis, along with a determination of which technology (wired or wireless) provides the best solution. Agencies can and should continue to coordinate with projects that provide opportunities to install dark fiber or conduit, making future use much more cost effective.

### **4.2 Wireless Solutions**

#### **4.2.1 Dataradio**

The existing Dataradio solution provides extremely good coverage throughout the County, and the system is currently being upgraded to provide increased bandwidth of 43.2 Kbps. The upgraded system will handle many of the mobile data applications that have been identified, although sizing of the system is critical to ensure that the system performance and response time is maintained and the system is not overloaded. Sizing will be accomplished based on the number of users, and the amount and type of transactions that will be transmitted through the system.

#### **4.2.2 WiMax**

WiMax is the next generation of Wi-Fi, or Wireless networking technology that will connect you to the Internet at faster speeds and from much longer ranges than current wireless technology allows. WiMax, short for ‘Worldwide Interoperability for Microwave Access,’ refers to any broadband wireless access network based on the new [IEEE 802.16](#) standard. WiMax technology can extend broadband wireless over longer distances and at higher speeds than current Wi-Fi or Bluetooth systems. Its access range, for instance, is up to around 30 miles, compared with Wi-Fi's 300 feet and

Bluetooth's 30 feet. It supports data transmission speeds up to 70M bit/sec, compared with the popular 802.11b Wi-Fi standard's 11M bit/sec or the 802.11a's 54M bit/sec. In addition to distance and speed advantages, WiMax doesn't require line-of-sight transmission.

WiMax will provide another means of transferring information wirelessly between centers, as well as out to roadside equipment or vehicles. This technology will allow many of the broadband projects identified by stakeholders to be deployed with a reduced investment when compared to installation of wired infrastructure, and may also be able to replace existing wired infrastructure thus eliminating monthly recurring costs. As described in the following paragraphs, WiMax is not yet an approved standard, but it is promising new technology.

There are two corresponding WiMax standards:

- IEEE 802.16-2004 for fixed point-to-point and point-to-multipoint wireless access. It's akin to a faster, airborne version of Digital Subscriber Line (DSL) or cable-modem services and became the industry's first non-line-of-sight (NLOS) broadband wireless access (BWA) standard last June.
- IEEE 802.16e, for mobile wireless access from laptops and handhelds. It is analogous to a faster version of third-generation telecommunications technology. WiMax proponent Intel has promised 802.16e-enabled laptops by early 2007. Intel is also involved in the 802.16-2004 standard by providing silicon to Alvarion, Proxim Corp. and Redline Communications Inc., which are manufacturing last-mile fixed products for the carrier market.

The technologies based on the two standards operate in licensed and unlicensed frequency bands below 11GHz. The standards are being overseen from a market-acceleration standpoint by a 230-company consortium called the WiMax Forum. Basically, the WiMax standards provide:

- QoS requirements are specified in the standard.
- Security (DES, 3DES and AES encryption) is specified in the standard.
- WiMax supports IP and traditional TDMA (circuit-switched) applications.
- Licensed spectrum is preferred for carrier-class WiMax service offerings. Early U.S. services are being developed for 5.8-GHz (unlicensed) band, because many regional carriers committed to WiMax don't hold licenses in the 2.5-GHz band, also approved for WiMax use in the United States. Outside the U.S., licensed 3.5-GHz bands will support WiMax. U.S. approval for 3.5-GHz WiMax usage is expected eventually.

A big WiMax selling point is that it comes with quality of service built in. Struggles with standardizing QoS have been a downfall of WiMax's cousin, 802.11 wireless LAN technology, or Wi-Fi, whose 802.11e QoS standard extension has been perennially six months away from being ratified.

What's actually described in the WiMax specification are four types of scheduling services for polling client devices about whether they have packets to send. The four classes apply to all versions of 802.16.

However, the specification describes only what is to be supported, not how vendors are to implement it. So whether different vendors' QoS implementations are actually interoperable will be determined when the WiMax Forum conducts product testing next summer.

Here are the basics of the four scheduled services specified by WiMax (in all cases, the base station controls scheduling):

1. **Unsolicited Grant Service (UGS)** will support VoIP without silence suppression to support a continuous packet stream.
2. **Real-Time Polling Service (rtPS)** will support VoIP with silence suppression (supporting packets sent only when a person is talking) and MPEG video.
3. **Non-Real-Time Polling Service (nrtPS)** involves polling devices periodically to maintain a minimum data rate for applications such as file transfers.
4. **Best Effort** means that there are no guarantees of service quality. But the speed and bandwidth provided by WiMax make it a good best-effort bet.

WiMax is being deployed from the top down as a carrier technology first, which means that schedules for service availability are dependent on widespread testing and buy-in. WiMax product standards certification and interoperability testing, overseen by the WiMax Forum and to be conducted by independent test lab Cetecom Spain in Malaga, is slated to begin in July.

Once services become available, growing business sites should gain inexpensive broadband access with speeds between T1 and T3 line capabilities. And because they're airborne, these services can be quickly deployed—often in a day's time—and bypass lengthy ILEC lead times.

The cost of local access is often 40% of a telecommunications bill. WiMax doesn't require dealing with lobbyists or tariffs.

Enterprises gain alternatives to the regional Bell operating companies and backups to terrestrial T1 and fiber links that can be cut at the same time. In addition, WiMax comes ready-made with provisions for quality of service; so many pre-standard services already support voice over IP, unlike many DSL and cable-modem options.

And standards-based technology should drive down customer premises equipment (CPE) costs for fixed connections, from about \$800 today to \$300 to \$400 in 2006 or 2007, it is possible that the WiMax CPE to drop to \$70 by 2007.

Businesses can buy WiMax-certified products to install in their campus-area networks as alternatives to private fiber connections and more-complex wireless bridging options.

According to vendors, service providers and analysts, starting in about 2007, an important 802.16-2004 application for enterprises will be disaster recovery—whereby the wireless link serves as either the primary or the backup connection. The reason is that two terrestrial links are likely to be cut simultaneously.

There's a cost advantage with wireless by paying about one-third the cost for a broadband wireless link as compared to a wired T1. When the mobile version of WiMax emerges, it will be possible to drive around with a broadband VPN for voice and data procured from a single provider.

Regional and local service providers can look forward to the benefits of WiMax, if they are delivered as promised in infrastructure equipment.

But WiMax services aren't necessarily a slam-dunk. The traditional big-name carriers refuse to publicly commit to the fledgling technology. Sprint Corp. and Nextel Communications Inc. likely have the most to gain from WiMax, because the merging companies collectively own a heap of spectrum in the 2.5-GHz licensed band, one of the U.S.-sanctioned frequencies for BWA traffic such as WiMax. The companies declined to comment on their WiMax plans, however.

Verizon Communications Inc. is focusing most of its last-mile efforts on a well-publicized fiber-to-the-home effort in 11 states.

Given that the Federal Communications Commission ruled in December to largely free telecommunications incumbents from their unbundling obligations to competitive local exchange carriers (CLEC), WiMax is perhaps one of the last-gasp hopes for getting better local-loop services faster at better prices.

At this time it appears that the industry won't see broad adoption of WiMax until 2009, when economies of scale are likely to kick in.

**Alvarion (Business Information Group).** The City of Wichita has recently signed a contract with a group including Computer Sciences Corporation (CSC) and Business Information Group (B.I.G.) to install a city-wide wireless network using Alvarion hardware for public safety users. The installation will leverage existing infrastructure where possible (primarily the existing licensed 45 Mbps bandwidth point-to-point microwave system connecting the schools), and installing additional fixed point where necessary, and mobile clients using 900 MHz modems in the vehicles. The Alvarion solution provides 1-2 Mbps to the vehicle with distances of 1-2 miles from the base station. The project will kick-off in late April 2005, followed by site surveys and system design, with installation scheduled to begin later this summer 2005.

#### **4.2.3 Leased Service**

Since the initial report was written, there has been significant consolidation in the area of leased services. Cingular and ATT Wireless have merged to become a single company, and Nextel and Sprint are in the process of completing a similar merger. At the same

time, there have also been significant enhancements to the data rates as true 3G bandwidth is becoming available in many areas. There are also new wireless initiatives that may bring opportunities for mobile data users. As indicated in Section 3.3, Application Infrastructure Relationship, many of the ITS applications do not require significant bandwidth, but they often have large geographic area coverage requirements. Leased services offer cost effective ways to provide wide-area coverage with higher throughput for data than is available on most private systems. Leased services can also provide both voice and data capabilities, including “push to talk” functionality commonly associated with private voice systems. Many agencies are transitioning many of their dispatch functions to leased services.

A brief description of the data capabilities for leased service providers follows.

**Cingular.** Cingular Wireless, the nation's largest wireless provider, announced plans to begin deploying a nationwide high-speed mobile wireless data network based on international standards. The third generation network will offer average data speeds between 400-700 kilobits per second (Kbps), and bursts to several megabits per second on capable devices.

People can now use their laptops to receive high-speed wireless data connections in more places as Cingular Wireless begins offering the first national unlimited EDGE/Wi-Fi data plan. Cingular customers can now receive unlimited high-speed data connections at nearly 4,000 Wi-Fi hotspots or when accessing the company's expanded EDGE (Enhanced Data Rates for Global Evolution) coverage area - domestically and internationally.

Through roaming agreements with other wireless carriers, Cingular recently increased its EDGE service area to cover more than 250 million people and now makes the service available in 13,000 cities and towns and in areas along nearly 40,000 miles of highways. When using a laptop and EDGE PC modem card, customers can receive average data speeds up to 135kbps with bursts to 200kbps. Cingular's EDGE service gives customers access to the fastest growing national wireless data network in the United States.

Cingular, a joint venture of SBC Communications Inc. (NYSE: SBC) and BellSouth Corp. (NYSE: BLS), will be building 3G UMTS (Universal Mobile Telecommunications System) with HSDPA (High Speed Downlink Packet Access) networks in a number of major urban and suburban markets beginning in 2005. UMTS devices will be backward compatible with EDGE.

Cingular's recent acquisition of AT&T Wireless provided the company with the spectrum necessary to build the 3G networks. Cingular, which pioneered the development of GSM at both 850 and 1900 MHz, intends to make the high-speed network available to not only its regional and rural roaming partners but also enable regional and rural carriers to deploy UMTS services on their networks as well. The UMTS/HSDPA service will enable enhanced services, including broadband-capable high-speed Internet access, wirelessly enabled enterprise productivity tools and audio/video streaming for business customers,



along with a host of consumer services such as high-resolution digital image and video capture and playback and advanced multi-player gaming.

**Verizon.** Verizon Wireless BroadbandAccess is one of the fastest, fully mobile wireless Internet data solutions available. Quickly download complex files and view email attachments at typical speeds of 300-500 kbps, capable of reaching speeds up to 2 Mbps. Access your mission-critical data and applications behind the corporate firewall and get the answers you need with customers in the field right there. Maximum possible speed varies. It declines with distance from cell site and is limited to 1.54 Mbps at certain cell sites with backhaul limitations. Number of users on the Verizon Wireless BroadbandAccess network may also affect maximum possible speed. Average upload speeds are expected to be between 40 and 60 Kbps.

BroadbandAccess' CDMA technology provides authentication and data protection and is compatible with many Virtual Private Networks (VPNs) so your organization doesn't have to worry about compromising security.

**Sprint.** Sprint Wireless High-Speed Data is the next evolutionary step for the Sprint CDMA network. Its high bandwidth capacity enables you to extend current and new enterprise applications to your mobile workforce. In addition, the CDMA-based Sprint PCS network offers the wireless security that ensures critical information can only be accessed by authorized users. Choose Sprint Wireless High-Speed Data access and enjoy an exponential jump in usability. Sprint is currently in the process of merging with Nextel, and plans to incorporate the “Direct Connect” capabilities into their solutions, while at the same time migrating the Nextel/Motorola iDEN technology to the CDMA technology used by Sprint.

Last summer Sprint became the first wireless service provider to offer a Service Level Agreement for its mobile voice services for business customers. Sprint's wireless data SLA guarantees 99.5% network availability, and that wireless data blocks will be less than 2% and wireless data drops will be less than 1%.

**Satellite Service.** There have been no significant changes in recent satellite service offerings. Mobile data using satellite systems remains more expensive, with slower data rates than competing public or private systems. The main benefit to satellite systems is the ubiquitous wide-area coverage as long as a line of site view of the satellite is available.

### **4.3 Hybrid Solution**

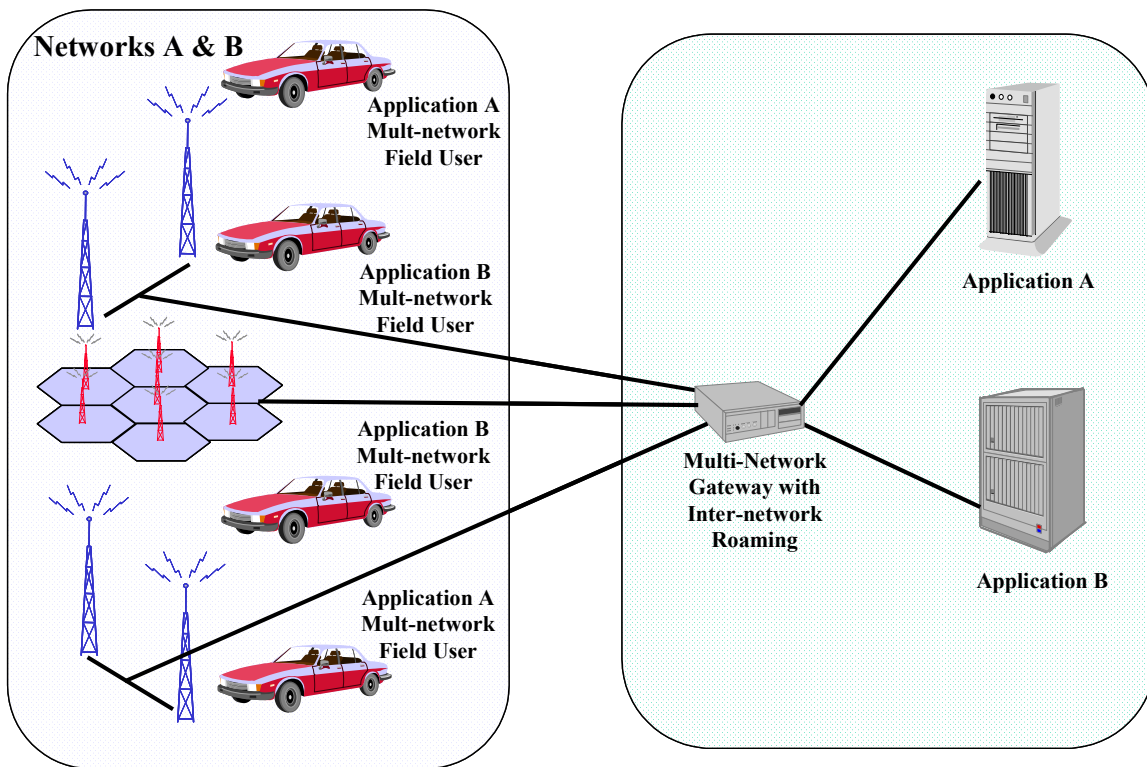
Hybrid systems involve using more than one network for a connectivity solution. This could include an optical fiber run along a freeway bringing video images back to a central location, integrated with a point-to-point microwave system sending the images back to a central office, or a wireless private RF network providing wide area coverage at a

relatively low bandwidth, and “hotspots” providing a small area of high speed throughput.

Multi-network roaming is commonly used to bridge two technologies. This allows the use of the most cost-effective solutions to handle communications where appropriate. Hybrid systems are intended for ITS personnel who are moving between locations, since fixed point-to-point communication systems by definition would not be roaming between networks. Hybrid systems can integrate solutions that cover different geographic areas, or provide different bandwidth capabilities. Hybrid systems can be established to satisfy both voice and data requirements. Communications paths can also be optimized to select the lowest cost network, highest performing network, or a specific network based on the application.

In a fully integrated wireless approach, a multi-network gateway is used along with a multi-network mobile configuration. Together with roaming support in the gateway, this allows the mobile user to roam between different wireless data networks and still communicate with the same applications. Roaming may be based on factors such as cost, performance and availability. However, mobile configurations that support multiple wireless data networks may be more expensive since vehicle or portable users need to be equipped with wireless modems for each network.

A fully integrated wireless approach is depicted in the figure below.



**Figure 91.** Fully Integrated Hybrid System

#### **4.4 800 MHz Voice Radio System**

Although it is currently a conventional voice radio system, there is an initiative to upgrade the existing Motorola statewide voice radio system to a trunked radio system that will be deployed over the next several years. The capability exists for a high-speed data system to be added using the same system infrastructure of antennas, towers and microwave backhaul communications. The existing Motorola data offering is 19.2 Kbps, but a new system is under development that would offer up to 96 Kbps data throughput, with data rates scaled down as distance from the base station increases. Coverage would be designed for mobile usage, so portable or in-building coverage could be problematic. While the data throughput capacities would still be somewhat limited, the statewide coverage provides an opportunity for data communications over a wide geographical area.

A private radio system offers increased security and reliability for system users. Typically these systems offer increased protection from power outages through the use of uninterruptible battery backup and generators that provide power for extended power outages. Users are limited to authorized personnel only, and voice and data loading is sized for the system thus minimizing risk of contention with other users. Private systems have a sizable start-up cost, but recurring costs are minimal, especially if spread over a large user base. In this case, a statewide system would provide extensive coverage, although most likely coverage would be designed for in-vehicle use as opposed to in-building coverage. As previously indicated, the private systems do not provide as much bandwidth as leased or hybrid systems for data throughput, but the throughput is adequate for most of the ITS applications (excluding CCTV, video cameras) that have been discussed. If reliability and control are required for the voice and data traffic being transmitted, private systems offer the most protection.

## **5 Communications Needs Analysis and Requirements**

There are a variety of different entities that either provide or receive data in the Intelligent Transportation System architecture. Communications paths will be determined based on the amount of data being exchanged, the geographic area being covered, the implementation timeframe for the respective interface, and other factors such as security. The ITS Architecture Entities include Centers, Roadside Equipment, Travelers and Vehicles. Data communications have been broken into high level communications paths including Center to Center, Center to Field, Center to Vehicle and Vehicle to Vehicle. Communication requirements are broken into low and high bandwidth applications, although the bandwidth assessment is based on individual device transmissions. As the number of users and frequency of transmissions increases, the bandwidth requirements may need to be reevaluated.

Center Communications include Archival Data sent to KDOT, Sedgwick County or City of Wichita data archive/repositories (high bandwidth), Information sent to commercial vehicles (low bandwidth), emissions data for the air quality alert system (low bandwidth) and fleet management information for fleet/freight systems (low bandwidth). In addition, toll administration information will be sent to Kansas Turnpike Authority (low bandwidth); traffic management information will be sent to the City of Andover 911, Kansas Turnpike Authority, and Sedgwick County and Wichita Traffic Operations Centers (bandwidth requirements dependent on amount of information transferred). Transit Management information (low bandwidth) will be sent to the Sedgwick County Transportation Brokerage Center and the Wichita Traffic Operations Center. Emergency Management Information will include a number of low and high bandwidth applications, and will be shared among the various 911 and dispatch centers, airports, Kansas Criminal Justice Information Center (KCJIS), and the National Warning System. The location of key centers has been identified on the map shown in Figure 92. All of the remote network facilities for Sedgwick County have been identified in the table included in Appendix B.



Figure 92. ITS Center Site Locations

Data from roadside equipment will provide information such as variable message sign data, highway advisory radio, ramp metering, traffic detectors, traffic signal data, and environmental sensors. These are all low bandwidth applications. Commercial vehicle information will also be transferred to the Kansas Commercial Vehicle Check System (low bandwidth), and Toll collections will be transferred to the KTA Toll Collection agency (low bandwidth). Other systems such as CCTV traffic cameras and video image processing will require much higher bandwidth to transfer the amount of data required.

At this time all traveler information will be provided by kiosks supported by either KDOT or the City of Wichita Transit. The location of these kiosks has not been identified, but they are typically in public areas such as the convention center or city hall. Connectivity is usually provided by a hardwired connection, although the increasing wireless bandwidth alternatives could allow the placement of a kiosk in a remote unwired site such as a commercial business or along a bus route.

Vehicle data as it is currently defined is low bandwidth because of the mobile infrastructure alternatives that have historically been available. This is changing in real time, as wireless infrastructure solutions are now capable of providing increased bandwidth, even broadband, to the vehicle. At the same time, mobile applications are becoming more robust, and the amount of data that can be transferred to or from the vehicle is increasing. Vehicles have been grouped by commercial, emergency, maintenance & construction, and transit vehicles. Commercial vehicle systems send cargo information, identification and security data to the vehicles, and can track mileage, fuel usage and other statistical data.

Emergency vehicles are capable of exchanging incident, dispatch, status and messaging information, along with location and HAZMAT information. Increasing amounts of data are being sent including fingerprints, mugshots and even video. Recipients include HAZMAT vehicles, Police, Fire, Sheriff and Highway Patrol vehicles, along with Transit Authority motorist assist and Airport public safety vehicles.

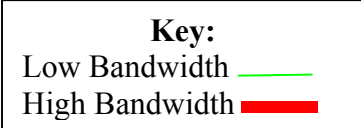
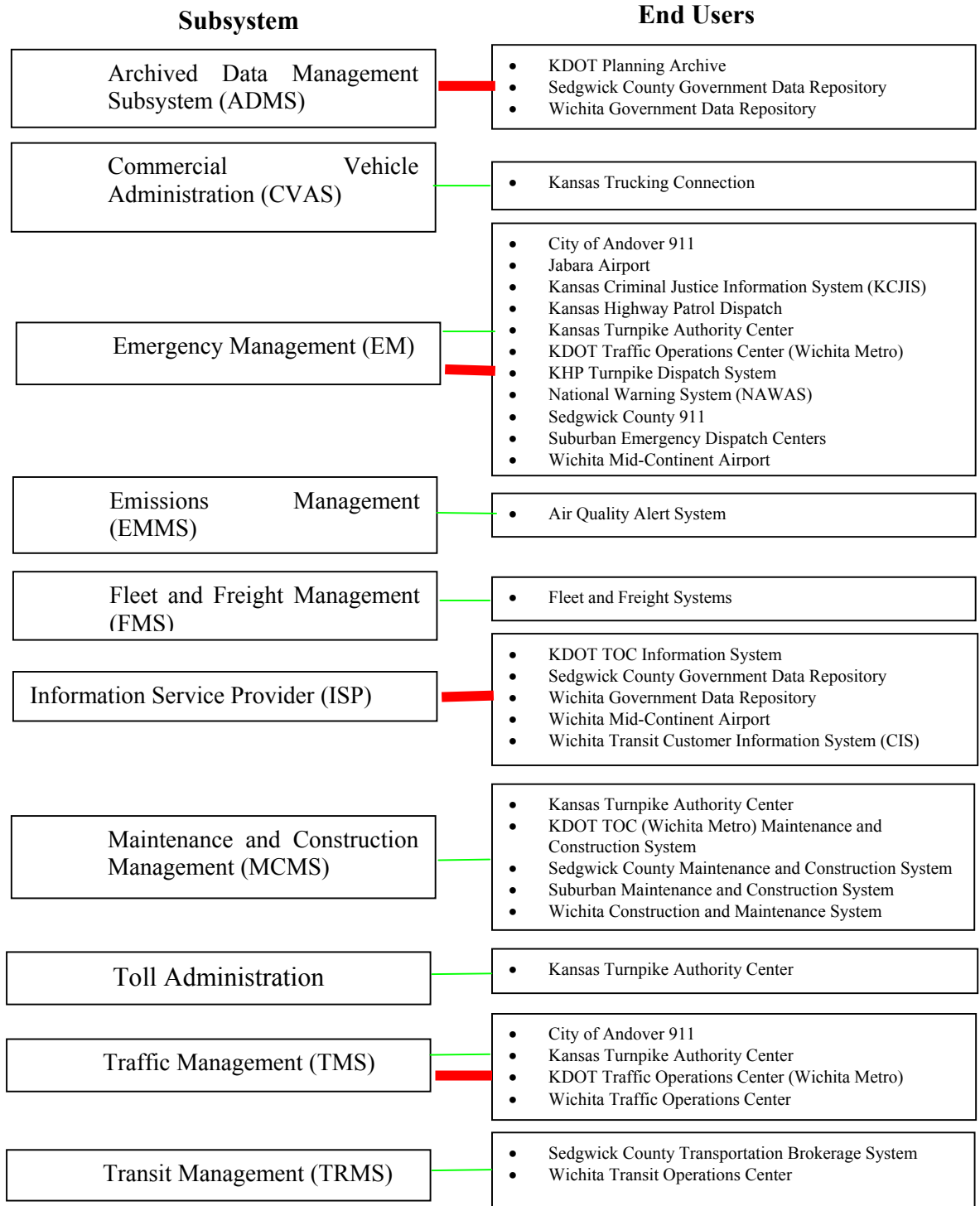
The maintenance and construction systems exchange location, sensory information, dispatch and messaging, vehicle maintenance information, and status of equipment such as the amount of salt remaining on a snowplow. The users of these systems include maintenance vehicles for KDOT, KTA, Sedgwick County and the City of Wichita.

Transit systems also exchange information among vehicles, including similar dispatch, communications and location information, but also are beginning to provide on-board safety and security information such as alarm information, chemical and biological threat sensors, and even video. Transit vehicles include busses, trains, paratransit and supervisory vehicles. They can also provide travelers with schedule, rates, routes, and transfer information. Both Sedgwick County and Wichita Transit vehicles will be communicating on the system.

The interfaces and end-user agencies that have been described above are shown at a high-level in the following illustration. The various solutions to satisfying the data

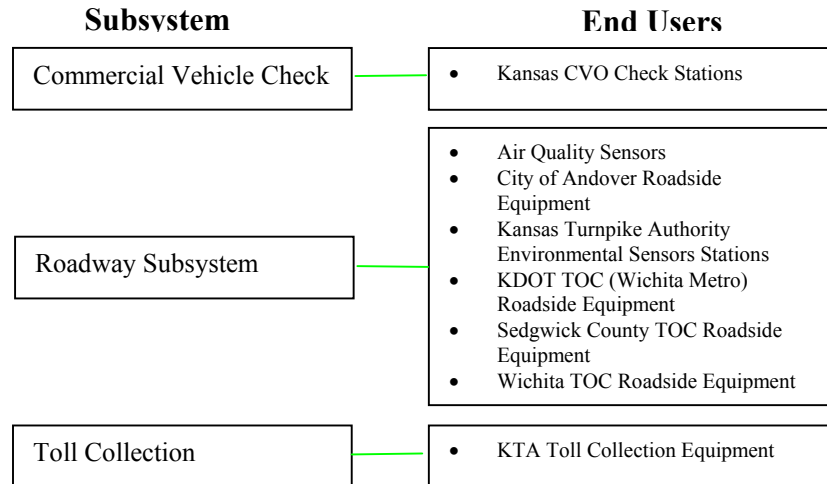
communications requirements identified herein are discussed in Section 6, Network Architecture Options.

Centers – Due to the extensive amount of information flow between centers, communication paths are expected to be primarily performed over wired infrastructure such as leased lines, or point-to-point microwave. The types of information being exchanged from centers to end users is shown below with a general observation of bandwidth usage (in some cases it can be both a low and high bandwidth data exchange):

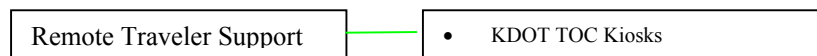




Roadside – Roadside equipment will be exchanging information between centers and end users. As indicated, most of the applications are low bandwidth and can be satisfied with low speed bandwidth solutions including twisted pair, leased or private RF systems, and leased lines.



Traveler – Traveler information will be provided by kiosks that are typically hard-wired, although new wireless technologies could allow kiosks in remote locations.



Vehicles – Information will be sent to vehicles via wireless infrastructure, and the available alternatives to send increasing amounts of data to the vehicle are increasing. Solutions now include private RF, leased services and wireless broadband in both licensed and unlicensed spectrum.

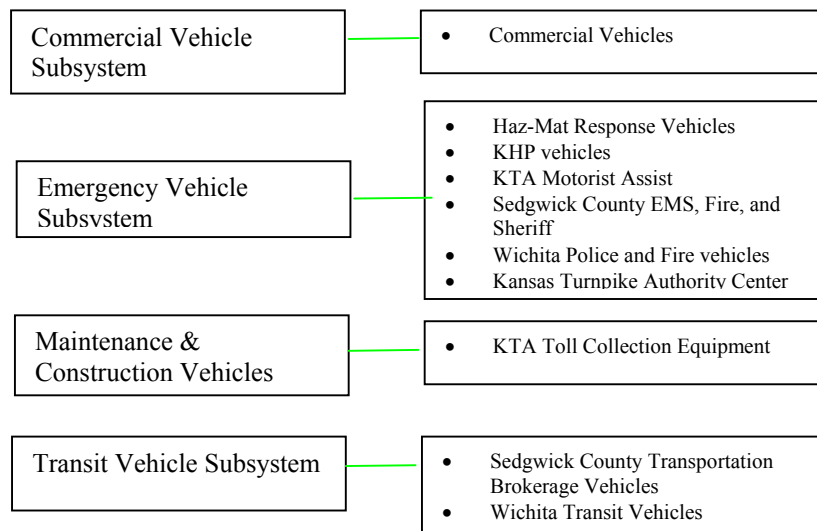
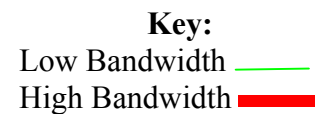


Figure 93. Architecture Generalized Bandwidth



ITS field devices require a given amount of bandwidth in order to function properly. The following values are not an exact value for all devices fielded but are a representative value of what is commonly fielded in a metropolitan area.

The following values shall be used for the purpose of estimating ITS device communication requirements and performing a data needs analysis effort.

• Intersection Traffic Signal Controller	4,800 bps
• Dynamic Message Sign	4,800 bps
• Ramp Meter	4,800 bps
• Vehicle Count Station / Traffic Detectors	4,800 bps
• RWIS (weather)	4,800 bps
• Route Diversion	4,800 bps
• Animal Warning	4,800 bps
• Pedestrian Safety Device	4,800 bps
• Highway Advisory Radio (TOC to HAR only*)	4,800 bps
• Highway Rail Intersection Device	4,800 bps
• CCTV (acceptable video for most ITS applications)	1.5 Mbps

\* If an agency is using a HAR, the agency has to provide communication infrastructure to get the data to and from the HAR to program the messages. Data transmitted from the HAR to the motorist's AM or FM radio is a licensed transmitter station and it is simply an audio broadcast message which is separate from this bandwidth calculation.

## 6 Network Architecture Options

This section will develop a list of alternative network approaches that each meet the needs identified. Communication media can be divided into the following two categories:

- Cabled Solutions
- Wireless Solutions

A description of available technologies within each of these categories is discussed below, beginning with an overview of various types of networks and network architectures.

### **LANs, WANs, and MANs**

A Local Area Network (LAN) is defined as a network within a single facility (usually a single building) that allows multiple devices, usually computers, to intercommunicate. A common use for a LAN is to transport data using the Internet Protocol (IP) standard. LANs can also transport other protocols, depending on the devices connected and purpose of the LAN. For instance, smart building systems might employ another communications protocol called BACnet (Data Communication Protocol for Building Automation and Control Networks, ANSI/ASHRAE Standard 135-2004). A LAN can also employ ATM (Asynchronous Transport Mode) protocol, although this is more likely in a Wide Area Network (WAN), defined later.

LANs can consist of several transport media, including copper wire, fiber cable, and a variety of wireless methods, including the commonly used IEEE 801.11 set of standard protocols (known as Wi-Fi under some implementations). The common standards used for physical wire are 802.3 (Ethernet) and 802.4 (token bus)/802.5 (token ring). IEEE 802.3 is the Ethernet standard which defines the method of transporting data over a typical copper-wire network for LAN and MAN networks. IEEE 802.5, Token ring, is another less commonly used (today) standard for copper wiring, which is used for LAN, MAN, and WAN networks. Token ring is also used in FDDI (Fiber Distributed Data Interface) networks, and FDDI-II. FDDI is commonly deployed for synchronous transport such as PCM and ISDN. There are several other protocols in use, and as the physical limits of various transport media are approached, and more creative use of compression and traffic management are employed.

For purposes of this document, a LAN will transport IP traffic, which may include converged applications. Converged applications of IP networks include such things as Voice over IP (VoIP), which commonly will involve the conversion of voice traffic into data for transport over the IP network – hence, converged. Other data can be converted to transport over an IP network through the use of devices such as Terminal Servers that can receive, for instance, serial connections. The conversion of the data by such devices involves a process of encapsulation, where the non IP traffic is surrounded and packaged by the IP protocol based on a defined standard of network layers commonly in use as the

TCP/IP standard, based on the International Standards Organization Open Systems Interconnection reference model.

The use of standards such as TCP/IP facilitates the growth of LANs and the ability to interconnect LANs using Wide Area Networks or Metropolitan Area Networks (MANs).

A Metropolitan Area Network (MAN) is a LAN extended over a large geographic area. Outside the IP world, CATV (cable television) networks are examples of MANs. MANs are seeing increase usage with the proliferation of high speed Ethernet both on copper wire and through Fiber in excess of 1 Gb/s. By comparison, a regular LAN typically runs at 10 Mb/s or 100 Mb/s, although 1Gb/s and higher speeds are now beginning to come into regular use.

### **Network Topologies**

There are several network topologies which define different configurations of physical and logical connection used to create the networks. There are some commonalities between data networks and communication networks when it comes to the varieties of topology.

A LAN or MAN can be called a subnet, whether or not it is divided into smaller segments through IP address subnetting and the use of Routers. When subnets are connected within a facility, they are generally still called LANs, when traffic has to leave the LAN and be transported to another LAN; it traverses a backbone, which is another way of referring to the interconnections used to make a WAN.

CCITT X.25 and X.75 protocols use Gateways to interconnect local networks. X.25 is used in the LAN, and X.75 is used on the WAN. These venerable protocols used a method of internetworking called Connection-Oriented Gateways. The Internet, through the use of IP, uses a Connectionless Gateway approach. The advantage of the Internet approach is that data is encapsulated within datagrams and those datagrams contain addressing source and destination information, which is added to at each layer as the data traverses the network. This provides inherent flexibility, because the network can be designed in such a way that multiple physical paths can transport the same data from source to destination; the path is not fixed, therefore Connectionless. In IP WANs, the gateways are Routers, and those routers can use a variety of protocols to determine the best way to get a data packet to its destination. One of these protocols is OSPF (open shortest path first), for example. There are several network Topologies used in the design of LAN (or MAN) and WAN networks. Depending on the topology, these networks will have varying levels of redundancy, availability, reliability, and quality.

Topologies used by LANs and WANs include Star, Ring, Tree, Complete, Intersecting Rings, and Irregular. Star, Ring, and Tree topologies are common LAN topologies. A star is accomplished using a Hub, where each node is connected via a single connection to a central Hub, and data must traverse that Hub to reach another node. A Ring is common in Token Ring networks, where each node is connected to two adjacent nodes, ultimately forming a ring, where traffic travels around the ring until it hits its destination (token is a

metaphor, as in a stick in a relay race, a token travels over this type of network, and is handed off to the next node). FDDI also uses a Ring topology. A tree network is similar to that defined earlier with the use of hubs attached to switches, where generally stars are at the end points if Hubs are used there. IBM's SNA (Systems Network Architecture) was a tree network topology (pre-Internet, although still in use, another example of a network which follows the OSI model).

Fiber networks can also use a topology called Passive Star, which is a broadcast method to send the inherently unidirectional fiber traffic from one transmitter to several interfaces/receivers.

Complete networks allow every node to connect directly to every other node. This is a common implementation for backplane networks within a multiprocessor computing platform. ATM Switching devices also use this topology inside their backplanes. Intersecting Ring and Irregular networks are hybrids which utilize components of complete and ring networks. ATM WANs often use Irregular networks, as do other implementations of WANs.

Complete and Irregular network topologies are also known as Mesh topologies, where nodes have the ability to directly interface/communicate with adjacent or distant nodes without transiting an intermediary. The Mesh topology has been adopted for use in wireless network devices, and is making possible a new and expanding field of networking called Ad Hoc Networking, detailed later.

Telephone switch networks use variants of these topologies, including a Fully Interconnected Network (same as Complete), Centralized Switch (same as Star), and Two-Level Hierarchy (a hybrid of Tree and Irregular). The terminology is of importance when discussing converged networks, particularly when Frame Relay or ATM networking is involved. The telecommunications network terminology includes the following network components:

- Local Loop: the twisted pair between a local phone company office and a user
- Toll Connecting Trunk: the lines between a local office and a Toll office
- High bandwidth Trunk: the lines between a Toll office and a Switching office

An important term/concept is the Trunk. A Trunk is a combination of several communications channels or wires into a single transport media (physical or wireless). In the world of converged multiservice networks, basically Frame or ATM networks, Trunks are commonly defined between network switching and routing nodes.

A wireless signal between two microwave tower sites on a WAN is generally considered to be a Trunk, and equipment at the tower site connected to the radio called a Channel Bank is used to isolate the individual streams of data into their constituent T-1/DS-1 parts. A T-1 represents a two-way connection which operates at 1.5 Mb/s, or in the telecommunications world, a Trunk of 24 regular telephone connections. Frame relay and X.25 protocols are commonly run across T-1 connections. T-1 connections are terminated

using a CSU (channel service unit), and a DSU (digital service unit). Many Routers will simply have a “T-1” port where the line out of the termination point or Channel Bank is connected. For Frame Relay networks which might transport both Voice and Data over the same T-1 (using different numbers of the “24” phone connections within the T-1), will include a MUX (multiplexer).

Trunks can consist of multiple T-1’s or DS-1’s (Digital Service lines). Multiple DS’s are named depending on the “level” of lines carried in the Trunk, for instance, DS-2, or Level 2, is four T1’s providing, DS-3, or Level 3, is 28 T1’s, etc.

**Cable**

Cabled solution (i.e., land-line, wire, cable), whether leased or owned, are by far the most prevalent form of traffic control system communication media. The three primary land-line transmission media commonly used in freeway management systems include the following:

- Twisted Wire Pair.
- Coaxial Cable.
- Fiber Optic.

**Twisted-Wire Pairs**

Twisted-wire pairs are the most prevalent type of communications media used in traffic control applications, and are currently used throughout the City. A twisted-pair cable consists of sets of two wires wrapped around each other. The twisting of each pair reduces interference from external sources because the pairs of conductors carrying the signal are always immediately next to each other in the cable. Therefore, the induced signal from the interfering source will affect each conductor of the pair similarly.

Table 1. Summary of Land-Line Technologies and Their Features

Features	Twisted-Wire Pairs	Coaxial Cable	Fiber Optics
Transmission Media	Copper Wires	Center conductor is copper clad aluminum Outer conductor uses aluminum	Glass or plastic fibers
Transmission Range	14 to 24 km (8.7 to 14.9 miles) with repeaters	Commercial subscriber network repeaters at 0.5 km (0.31 mi); 1 km (0.62 mi) or more on dedicated systems; maximum of approximately 60 repeaters	Rarely a limitation when drop/insert units used at communications hubs or drop points
Principal Multiplexing/Modulation Technique Used	Time Division Multiplex (FSK)	Frequency Division Multiplexing to divide channel bandwidths; Time Division Multiplexing to communicate data	Time Division Multiplex (FSK)

Carrier Frequency Band	300 to 3000 Hz	5 MHz to 350 MHz	850 to 1,550 nanometers
Bandwidth/Channel Bandwidth	Will exceed 2.7 Hz for most systems	6 MHz/channel	Various
Data Rates per Channel	1,200 to 3,100 bps Higher rates possible with different modulation techniques	Up to 7.5 Mbps based on channel subdivision	Up to 10 Gbps
Government Regulation of Channel or Service	None	May require licensing from local and state authorities, FCC provides legislation	None
Types of Information Supported	Data, voice, slow scan TV	Data, voice, video	Data, voice, analog TV, Codec
Owned or Leased	Owned	Either	Owned

Most twisted-wire pair cabling used in traffic control systems is usually of the voice-grade type. This means the usual bandwidth (the range of signal frequencies a medium or channel will respond to, or carry without excessive loss in signal strength) ranges from 300 Hz to 3000 Hz, the audible frequency range of the human voice. Twisted-wire pair cabling is commonly used in voice telephone communications. A voice-grade cable will accommodate a data transmission rate of 1,200 bits per second (bps), which is adequate for transferring small amounts of data (i.e., loop detector data). When higher data transmission rates are required (for trunking applications), the twisted-pair cable must be conditioned by adding electronic equipment, such as loading coils, to improve the transmission characteristics of the line.

Twisted-wire pair technology is an inexpensive communications medium whose acquisition cost is lower than that of both coaxial and fiber-optic technologies; however, long term operating costs are dependent on installation considerations and are higher when life-cycle costs are considered. The extent of such costs will vary greatly with the different installation.

Table 2. Advantages and Disadvantages of Twisted-Wire Pairs.

<b>Advantages</b>	<b>Disadvantages</b>
<ul style="list-style-type: none"> <li>• Represents a low cost form of transmission.</li> <li>• Easy to splice.</li> <li>• Requires no special interface equipment.</li> <li>• Electrical characteristics are very favorable to basic analog transmission.</li> </ul>	<ul style="list-style-type: none"> <li>• Data cable splicing is not recommended.</li> <li>• There is a bandwidth limitation in that twisted-wire pair tends to attenuate high-frequency electrical signals, thereby limiting the ability to transmit digital information at high data rates.</li> <li>• Bandwidth limitation prevents transmission of live television images, though recent developments permit</li> </ul>

	transmission of slow-scan television. (Prototype equipment is available for transmission of full-motion television over twisted-pair copper wire.) • Low Security
--	---

**Coaxial Cable**

Coaxial cable technology can transmit either data or video via several communication channels. Because of the high bandwidth it provides, it is commonly used for traffic cameras, sending video back to the centers, or interconnecting local devices. Its name is derived from its characteristic shape, essentially a set of two concentric circles. The cable consists of an unbalanced pair made up of an inner conductor within an outer conductor held in a concentric configuration by a dielectric material that separates the two conductors. A coaxial cable system uses frequency division multiplexing (FDM) and time-division multiplexing (TDM) to fit all traffic control signals on a single conductor. FDM is used to subdivide the cable bandwidth into appropriate channels for data, video, and voice transmission, and TDM is then used to communicate the data.

Table 3. Advantages and Disadvantages of Coaxial Cable

<b>Advantages</b>	<b>Disadvantages</b>
<ul style="list-style-type: none"> <li>• Because of its physical structure, coaxial cable is more immune to electromagnetic interference and has a much higher bandwidth than twisted-pair cable.</li> <li>• Minimal signal losses.</li> <li>• Low signal leakage.</li> <li>• Higher bandwidth allows for transmission of video signals (cable television using coaxial cable can transmit as many as 75 independent video signals) and for the transmission of digital data at very high rates.</li> <li>• Bandwidth of coaxial cable permits theoretical transmission rates as high as 700 million bits per second (Mb/s). These rates are more favorable than typical twisted-pair rates that are limited to less than 24 Mb/s for short distances.</li> </ul>	<ul style="list-style-type: none"> <li>• Splice connections are susceptible to noise and transient problems.</li> <li>• Cannot be spliced together by manual strip and twist method. Inherent nature of cable, and the importance of conductor alignment, make the coaxial cable much more difficult to splice.</li> <li>• Lower communication reliability than fiber optic.</li> <li>• Higher maintenance and adjustment effort required compared to fiber optic.</li> <li>• Low security.</li> <li>• Cannot be conventionally “tapped.” Requires termination.</li> </ul>

Coaxial cable’s physical structure is less affected by electromagnetic interference than twisted wire pairs. Repeater amplifiers have low noise levels and can deliver strong signals over a wide range of output levels; however, coaxial cable does experience moderate signal attenuation losses. Coaxial systems amplify the signal at each repeater, instead of regenerating it. As a result, background noise is also amplified at each



repeater.

The attenuation in a given coaxial cable varies as a function of frequency, temperature, and cable size. Attenuation levels roughly double each time the bandpass frequency quadruples. Temperature variations can also degrade performance.

**Fiber Optic**

Fiber optic communication provides a high volume, cost-effective means of transmitting either data or video via several communications channels with immunity to electrical interference. Fiber optic cable provides significantly higher bandwidth for transferring data, and is relatively immune to interference. Advances in technology have increased the lengths that data can be transferred, and reduced installation costs. Fiber is an excellent medium for interconnecting fixed facilities such as center-to-center communications, providing essentially unlimited amounts of bandwidth. KDOT has installed fiber along main highway corridors, as well as conduit that will allow for fiber installation in the future. Its name is derived from the medium’s use of an optical fiber to transmit light by means of internal reflection off the surrounding surface cladding. Essentially, light impulses are coded and transmitted into a glass fiber structure. The fiber itself confines and guides the beam of light between origin and destination points. Upon reaching its destination, the light signal is detected, converted to electrical pulses, and decoded to an appropriate output.

Fiber optic technologies are more expensive to acquire than comparable metallic transmission media; however, fiber optic cable has a reduced life-cycle cost when compared with copper transmission media, and is increasingly being used to replace coaxial cable systems. Because of the high cost of fiber optic systems as compared with copper transmission, they are typically used for trunking applications in which large amounts of information must be transmitted over long distances or for high-speed local area networks that are to be distributed over a campus area.

Table 4. Advantages and Disadvantages of Fiber Optic Communications

<b>Advantages</b>	<b>Disadvantages</b>
<ul style="list-style-type: none"> <li>• A pair of light tubes can support many more circuits than a metallic path.</li> <li>• Immunity from electromagnetic interference (EMI) and radio-frequency interference (RFI).</li> <li>• High integrity for data transmission.</li> <li>• Emits no radiation and it is difficult to tap a fiber tube without detection of the resulting signal loss, thus represents a highly secure means of communication.</li> <li>• Use of small cable diameters and low weight cable.</li> <li>• Small bending size, small bending radius, and light weight.</li> </ul>	<ul style="list-style-type: none"> <li>• Designing a fiber optic network tends to require substantial engineering effort due to complexity of networks, light distribution characteristics and medium, and other factors.</li> <li>• Splicing tends to require elaborate equipment and expertise.</li> </ul>

<ul style="list-style-type: none"> <li>• Safety in hazardous environments.</li> <li>• Extremely flexible - can be installed to support a low-capacity (low-bit-rate) system and, as the system's requirements expand, can use broadband capabilities of optical fibers and convert to a high capacity (high-bit-rate) system simply by changing the terminal electronics.</li> </ul>	
--	--

Because of its dielectric nature, fiber optic communication medium is unaffected by electrical signals. As a result, many problems such as radiative interference, ground loops, and lightning-induced damage (when fiber optics have been installed in a cable without metal) can be avoided with fiber optic technology. This property makes fiber optics an ideal communication medium in a noisy electrical environment.

Fiber optics is, however, affected by dispersion and attenuation. The negative impacts of these two factors increase with the number of modes, and limit the length of a given fiber optic link although with modern laser transmission equipment and single mode cable the distances between equipment is measured in tens of miles.

**WIRELESS**

Wireless systems are currently used to transmit information between some centers via microwave, as well as to vehicles using the County's private Dataradio network. Wireless will be used even more extensively in the future for transmitting information to vehicles via the planned Alvarion broadband wireless network that will be installed throughout the City, as well as point to point connectivity between fixed facilities. In addition, the Dataradio network upgrades will allow roughly four times as much data to be transmitted with County-wide coverage. Wireless network components include the use of any component of the radiation spectrum to transfer data between two points, generally line-of-sight (although often beyond the capabilities of human sight). This includes, in typical use, lasers, microwaves, and radio spectrum. Access to the radiation spectrum is controlled by governments. Therefore, two "types" of spectrum "space" usable for network technologies are available, Licensed, and License-free.

License-free frequencies currently include:

Spread-spectrum wireless equipment operating at:

- 900 to 928 MHz
- 2.4 to 2.483 MHz
- 5.725 to 5.850 MHz

Non-spread spectrum wireless equipment operating at

- 5.15 to 5.25 GHz
- 5.25 to 5.35 GHz
- 5.725 to 5.825 GHz

It should be noted that, although infrequent, the government can reallocate any license-free frequency to licensed frequency, and therefore, most WAN uses of wireless systems operate within licensed frequencies, where change is slower, but not unheard of.

There are several factors that affect the quality of a wireless network link. Wireless spectrum can be affected by a variety of atmospheric conditions, obstacles between the transmitter and receiver, and by interference from other wireless spectrum users. Several parts of the radiation spectrum are used for wireless data communications networks, from laser (visible, infrared, and ultraviolet) to radio. Power, distance, and focus also affect these transport methods. Wireless engineering is a highly technical field, involving the study of the wide variety of parameters in designing a line-of-sight path, antenna systems, link budgets (a calculation involving signal gain and loss, revealing the reliability of the link), and use of different spectrum for different purposes/distances. Data, Voice, and Converged networks rely on the engineering of all of these factors. Any wireless link, from unlicensed short-range networking to long-range licensed or unlicensed links should be carefully evaluated to ensure that the proper quality, redundancy, bandwidth, and reliability are present to meet the needs of the user.

Wireless systems used for common data networks can be categorized into four levels: Wireless Personal Area Networks (Wireless PANs), which use technologies such as Bluetooth or Infrared signals; Wireless LANs, Wireless MANs, and Wireless WANs. There are a wide variety of protocols, methods, standards, and topologies used for Wireless systems, including Cellular networks.

Wireless MANs (WMANs) utilize a variety of technologies, including Broadband Wireless Access (BWA). Three network topologies come into play: point to point, and point to multipoint (this is cell technology, known in the wired world as Irregular or Complete, depending on the design), and Mesh architecture. The IEEE 802.16 standard deals with point-to-multipoint topologies for Fixed BWA operating at 10 to 66 GHz. This standard uses DAMA-TDMA (Demand assignment multiple access-Time division multiple access) frame/timing methods. This standard allows WMANs to interconnect over ATM networks, and provides for convergence services (ATM, multicast, video applications, Frame Relay, etc.) at data rates up to 155 Mb/s. These first-mile networks are interconnected with backbone technologies such as microwave networks running ATM, IP, or Frame Relay, or SONET (synchronous optical networks) used to transport multiple services.

IEEE 802.16b/e, WiMax, as previously described in Section 4.1, is a currently emerging standard, foreseen to become a primary solution for backhaul between wireless access points (Wi-Fi hotspots). WiMax is a point-to-multipoint architecture, and is seen by some in the industry as potentially competing with 3G and 4G networks. WiMax reportedly provides up to thirty miles range.

Mesh architecture networks use multipoint-to-multipoint topologies. Every node in a Mesh network is a router or repeater, and every node can be an “end” node connected to a wired network. Mesh networks commonly use 802.11 equipment; however the topology

can be implemented using other frequencies. The advantages of the Mesh topology include: “self-healing,” dynamic route reconfiguration, redundancy. Mesh networks are classified as LANs, and would interconnect to WAN or LAN backbones.

Another wireless technology which is increasing in popularity is DSRC (Dedicated Short Range Communication). A common implementation of DSRC is RFID (Radio Frequency Identification), used for various purposes including automated toll systems, short-range vehicle tracking, ID badges, and inventory tracking. The FCC has allocated “5.850-5.925 GHz band for a variety of Dedicated Short Range Communications (DSRC) uses, such as traffic light control, traffic monitoring, travelers' alerts, automatic toll collection, traffic congestion detection, emergency vehicle signal preemption of traffic lights, and electronic inspection of moving trucks through data transmissions with roadside inspection facilities” (FCC 99-305 and 03-324A1). There are several initiatives in Departments of Transportation and within the automobile industry to implement DSRC on a wide scale for these purposes as defined by the FCC. These implementations can also include the integrated use of GNSS-CN (Global Navigation Satellite Systems (GPS) Cellular Network (GSM). This technology is also referred to as DSRC-WAVE (DSRC in a Wireless Access Vehicular Environment, IEEE 802.11p). DSRC can support bandwidths from 6Mb/s to 27Mb/s up to 1000 meters distant from vehicle moving at a high speed.

### **Wireless in ITS**

Several forms of wireless communications technologies commonly used in freeway management systems include the following:

- Area-wide radio networks.
- Terrestrial microwave links.
- Spread spectrum radio.
- Cellular radio.
- Packet radio.
- Satellite transmission.

The following table summarizes the characteristics and features of the wireless communications technology used in freeway management systems. The first three of these communication media are generally owned by the public agency while the last three can generally be leased from commercial providers.

Table 5. Wireless Communication Technologies and Their Associated Properties

Technology	Principal Multiplexing/ Modulation Technique Used	Carrier Frequency Band	Bandwidth/ Channel Bandwidth	Data Rates per Channel	Transmission Range or Repeater Spacing	Government Regulation of Channel or Service	Types of Information Supported	Owned or Service	Constraints on Use
Area Radio Network	Time Division Multiplex, Modulation technique varies	15-174 MHz 405-430 MHz 450-470 MHz 928-960 MHz	25 KHz channels	9.6 Kbps	Several kilometers	FCC licensing of channels for each network	Data	Owned	Channel availability, line of sight in 900 MHz band, multipath sensitivity, geometries
Microwave	Time Division Multiplex, Modulation technique varies	928 MHz to 40 GHz	Various	Up to 7.5 Mbps depending on channel allocation	Varies, may extend several kilometers	FCC licensing of channels except for channels in 31 GHz band for each installation	Data, voice, analog TV, Codec	Owned	Channel availability, line of sight availability, multipath sensitivity, geometries, weather
Spread Spectrum Radio	Time Division Multiplex, Modulation technique varies	902 - 928 MHz 2.4 GHz, 5.2/5.3 GHz 5.8 GHz	Various	200 Kbps (typical)	0.8 km (0.5 mi) to several km	No license in the 902-928 MHz band for the network	Data, Codec	Owned	Line of sight, geometries, protocol compatibility
Cellular Radio	Because of narrow channel width, usually only simple polling or other multiple access techniques	825-845 MHz for mobiles, 870-890 MHz for base stations, 20 MHz in reserve	30 KHz per channel	1.2 to 14.4 kbits/sec, depending on modem type used	3.2 - 16 km (2-10 mi) per sector or "cell"	FCC has divided U.S. into 734 service areas, two cellular operators licensed/area	Voice, data	Service	Transmission cost, data transfer limitations
Packet Radio	Multiple access protocol	800 and 900 MHz bands	12.5 and 25 KHz channel widths	4.8 to 8 kbits/sec; 19.2 kbits/sec in major cities	16 - 32 km (10-20 mi) per base station		Data	Service	Service limited to major cities, time delay in delivery
Satellite Transmission	Frequency Shift Keying, Minimum Shift Keying, Phase Shift Keying	C Band (4-6 GHz) Ku Band (2-4 GHz)	Various	Various, depending on system complexity	Essentially unlimited, based on coverage area	FCC allocates frequencies for fixed satellite communication	Data	Service	Availability in some geographic areas, cost

### **Area-wide Radio Network**

Area radio networks derive their name from their ability to broadcast signals to an area as opposed to a specific location. Area Radio Networks operate in the 150 MHz to 960 MHz bands; the 450 to 470 MHz and 928 to 960 MHz bands are the most commonly used. Bandwidth channels in the 25 KHz range are often used for data transfer and can support a signal rate of 9.6K bits/second; however, they will not support video transmission.

While the scattering and reflection of radio signals allow the signal to propagate into built up areas, they also reduce the signal strength. Terrain barriers and weather factors can also interfere with the performance of area radio networks. Operation of area radio networks requires an FCC license. The design of radio communication systems is complex and often requires special expertise.

### **Microwave**

Microwave systems convey point-to-point messages at very high frequencies that allow for reuse at small distances. Microwave systems are expensive due to the infrastructure costs required to interconnect communications. These infrastructure requirements are directly attributable to the operating frequency in use. Higher frequencies require smaller antennas that in turn have fewer extensive infrastructure needs; however, the larger antennas typically required by 2 GHz and 6 GHz systems cost more to purchase, are more difficult to install, and require stronger support structures due to their higher wind loads.

In terrestrial microwave technology, microwave signals are radiated through the atmosphere along a line-of-sight path between highly directional microwave frequency transmitting and receiving antennas. Use of microwave radio allows transmission in both directions simultaneously, however, rainfall, heavy fog, and other atmospheric factors can reduce the power of the signal below a usable level.

### **Spread Spectrum Radio**

Spread spectrum radio systems operate by transmitting a signal bandwidth over a wide range of the frequency spectrum. To receive such a broadband transmission, the signal is compressed to the original frequency range at the receiver. The infrastructure equipment necessary to operate an unlicensed spread spectrum communication system is readily available.

Because of the low-power requirements and general availability of required system components, this communications medium is considered a low-cost technology.

Spread spectrum technology was originally developed by the military to resist enemy radio interception and jamming during World War II. Spread spectrum broadcast techniques allow receivers to decode spread spectrum signals even if background noise levels exceed the signal level and they can resist the effects of multipath interference. This technology is considered to have a security advantage over similar wireless transmission techniques; intentional interference with spread spectrum communications is extremely difficult unless the transmission technique is known.

### **Cellular Radio**

Cellular radio is a new data transmission medium that has grown rapidly since its introduction in 1983. The Federal Communications Commission has designated 666 channels in the 800 MHz band for cellular service purposes. Cellular communication systems are small radio sectors or “cells” that provide communications coverage in a series of small, slightly overlapping areas. The cells are sized to reflect the density of users in a given area, and typically cover between 0.5 to 5 miles each. An antenna is placed in each cell so that, within a given system of cells, antennas relay signals through the system via a series of communications with their closest counterparts. The frequencies used for transmission in one set of cells can be reused in another set of cells by keeping the two signals far enough apart to avoid interference.

### **Packet Radio**

Packet radio services were designed for the transmission of data via wireless means. The distinction between packet radio and the evolving cellular packet data technology is becoming increasingly blurred, except that packet radio does not support voice communications. Packet radio technology is expensive and is not cost effective for file transfers or continuous communication purposes. Specific costs will depend on the service provider and will likely include an initial subscription fee, monthly service fees, and modem and terminal charges.

### **Satellite Transmission**

Satellite communications make use of space-based equipment to relay signals transmitted from earth. Unlike other means of communication, because of the relay equipment’s location in space, satellite transmission technology is less dependent on the relative location of transmitters and receivers. The cost of making frequent satellite transmissions is generally considered excessive in comparison with that of other technologies. As with the other technologies examined, advances in the satellite industry will continue to enhance the economics of communications via satellite transmission. Satellite communications may make sense for a small number of users that require statewide coverage, especially if used as a part of a hybrid network that can also make use of other more cost-effective terrestrial-based systems.

# Appendix A – Leased Cellular Coverage Maps

- Digital Cellular and local walkie-talkie coverage (approximate)
- Digital Cellular and coast-to-coast walkie-talkie coverage
- Estimated Future Coverage

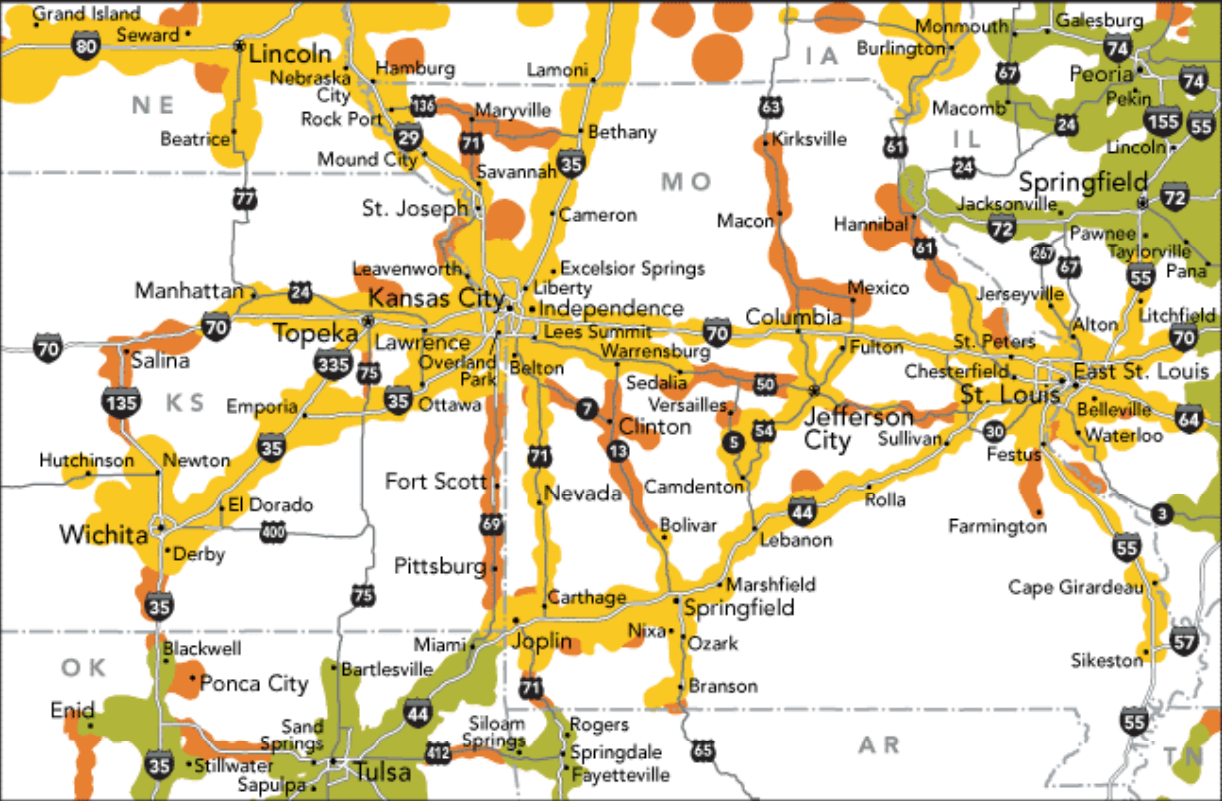


Figure 94. Nextel Coverage Map



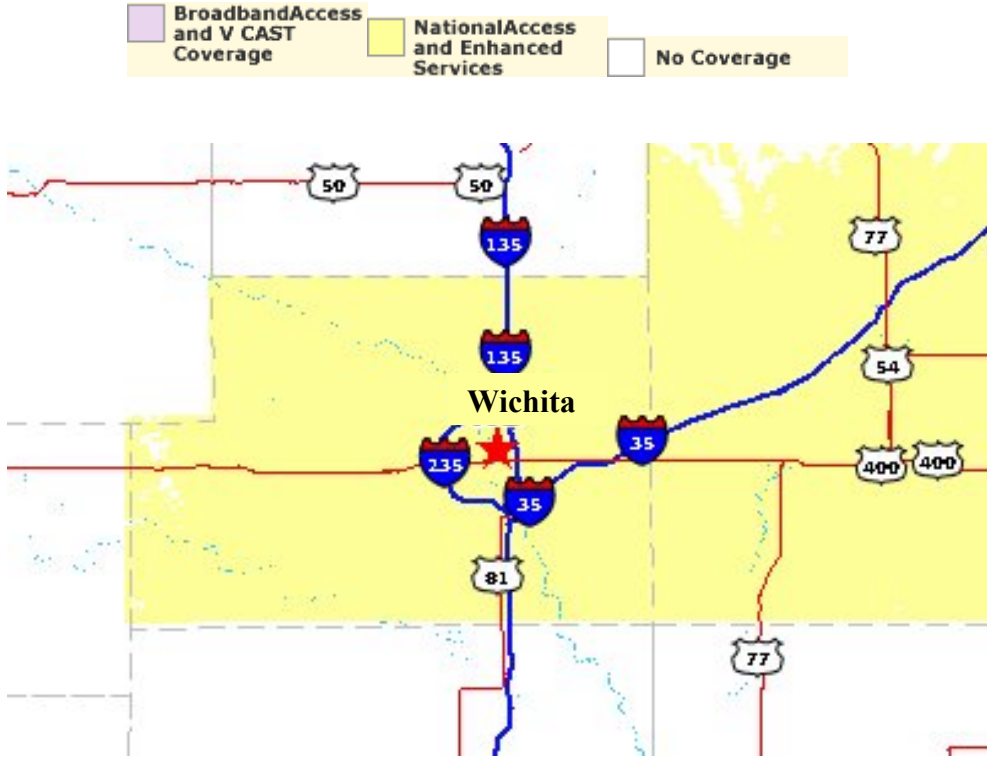


Figure 95. Verizon Wireless Coverage Map

■ T-Mobile digital coverage area

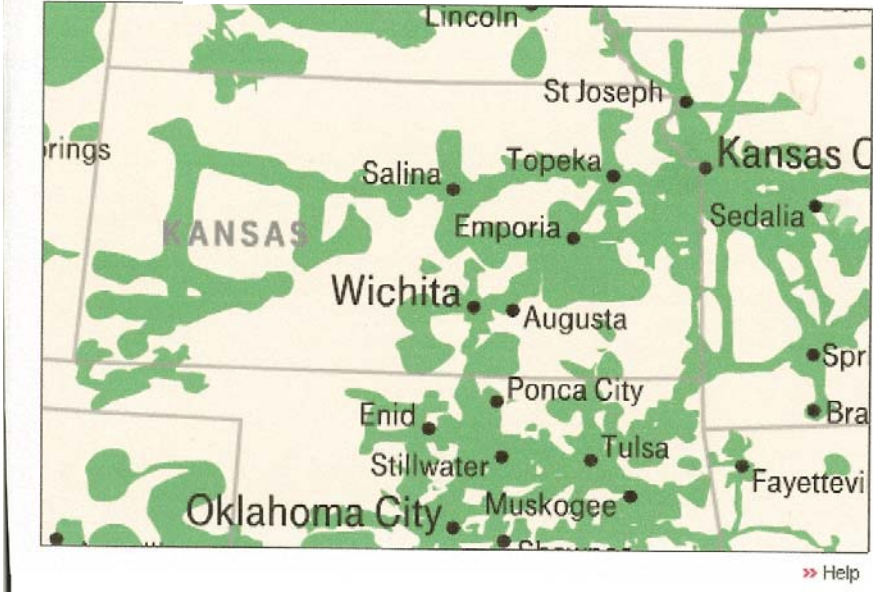



Figure 96. T-Mobile Coverage Map

## CINGULAR NATION

No Long Distance or Roaming Charges Nationwide.

 **Cingular Nation (with a 850 Mhz/1900 Mhz dual-band GSM handset)**

- Anytime, Mobile to Mobile and Night & Weekend Minutes apply

 **Future Coverage**

- Estimated availability by June 2004

 **No Service Area**



Figure 97. Cingular Wireless Coverage Map

## Appendix B – Sedgwick County Network Remote Sites

SITEID	CAMPUS	SITENAME	DEPARTMENT	ADDRESS	CITY	NETWORK	NUMUSERS
1	Stand Alone Facility	Radio Shop	911	1901 N Market St	Wichita	ISDN	5
2	Stand Alone Facility	Aging - Augusta	Aging	Augusta	Augusta	ISDN	0
3	Stand Alone Facility	Aging - Newton	Aging	209 N Pine St	Newton	ADSL	0
4	Stand Alone Facility	Aging NE Center	Aging	2121 E 21st St N	Wichita	T1	0
5	Stand Alone Facility	Appraiser's West Site	Appraiser	940 N Tyler Rd	Wichita	T1	0
6	Stand Alone Facility	Children's Care	CommCare	7701 E Kellogg St	Wichita	50M	67
7	Stand Alone Facility	City Center Homeless Shelter	CommCare	154 N Topeka Ave	Wichita	Unknown	0
8	Stand Alone Facility	Community Care - Center City	CommCare	154 N Topeka Ave	Wichita	T1	11
9	Stand Alone Facility	Community Care - Hunter	CommCare	731 S Hunter St	Wichita	ADSL	2
10	Twin Lakes	Community Support Svcs (CSS)	CommCare	1910 W 21st St STE 48	Wichita	50M	79
11	Twin Lakes	Family & Children's Care	CommCare	1919 N Amidon STE 130	Wichita	50M	0
12	Twin Lakes	Intake & Assessment	CommCare	1919 N Amidon STE 211	Wichita	50M	39
13	Stillwell	Aging Traffic	Community Development	1015 W Stillwell Ave	Wichita	50M	0
14	Stillwell	Animal Control	Community Development	1015 W Stillwell Ave	Wichita	50M	0
15	Stillwell	EMS Admin	Community Development	1015 W Stillwell Ave	Wichita	50M	0
16	Stand Alone Facility	Neighborhood Economic Dev.	Community Development	520 W Douglas Ave	Wichita	Unknown	0
18	Stand Alone Facility	EMCU	Corrections	230 E William St	Wichita	T1	22
19	Juvenile	JIAC	Corrections	1720 E Morris St	Wichita	T1	13
20	Lake Afton	Judge Riddle's Boys Ranch	Corrections	25331 W MacArthur Rd		T1	29
21	Stand Alone Facility	Juvenile Field Svcs (JRFS)	Corrections	961 S Glendale Ave	Wichita	T1	38
22	Juvenile	Juvenile Res Facility JRF	Corrections	881 S Minnesota Dr	Wichita	45M	0
23	Stand Alone Facility	Region Forensic Science Ctr	Corrections	1109 N Minneapolis Ave	Wichita	T1	34
24	Stand Alone Facility	Work Release	Corrections	701 W Harry St	Wichita	T1	0
25	Stand Alone Facility	Coliseum	Culture, Entertainment & Recreation	1229 E 85th St N		T1	18
26	Stand Alone Facility	Cowtown	Culture, Entertainment & Recreation	1871 Sim Park Blvd	Wichita	ISDN	16
27	Sedgwick County Park & Zoo	Extension Office	Culture, Entertainment & Recreation	7001 W 21st St N		ADSL	2
28	Sedgwick County Park & Zoo	Sedgwick County Park	Culture, Entertainment & Recreation	6300 W 13th St N		ADSL	0
29	Sedgwick County Park & Zoo	Sedgwick County Zoo	Culture, Entertainment & Recreation	5555 W Zoo Blvd		T1	57
30	Juvenile	Friendly Gables	District Attorney	1001 S Minnesota Dr	Wichita	45M	0
31	Juvenile	Friendly Gables	District Attorney	1001 S Minnesota Dr	Wichita	45M	0
32	Juvenile	Friendly Gables	District Attorney	1001 S Minnesota Dr	Wichita	45M	0
33	Juvenile	Friendly Gables Building B	District Attorney	1001 S Minnesota Dr	Wichita	45M	0
34	Juvenile	Juvenile Courts	District Attorney	1015 S Minnesota Dr	Wichita	45M	0
35	Juvenile	Juvenile Detention Fac. (JDF)	District Court	1900 E Morris St	Wichita	T3	0
37	Stand Alone Facility	EMS - Wesley	EMS	550 N Hillside Ave	Wichita	ADSL	0
38	Stand Alone Facility	EMS Post 1	EMS	2622 W Central Ave	Wichita	ADSL	2
40	Stand Alone Facility	EMS Post 11	EMS	1401 N Rock Rd	Derby	ADSL	3
41	Stand Alone Facility	EMS Post 12	EMS	3320 N Hillside Ave	Wichita	ISDN	0
42	Stand Alone Facility	EMS Post 2	EMS	1903 W Pawnee Ave	Wichita	ISDN	2
43	Stand Alone Facility	EMS Post 3	EMS	6240 Shadybrook St	Wichita	ADSL	0
44	Stand Alone Facility	EMS Post 4	EMS	1100 S Clifton Ave	Wichita	ADSL	2
45	Stand Alone Facility	EMS Post 45	EMS	616 E 5th St	Valley Center	ISDN	2
46	Stand Alone Facility	EMS Post 5	EMS	698 Caddy Ln	Wichita	ADSL	4
47	Stand Alone Facility	EMS Post 6	EMS	6401 S Mabel St	Haysville	ADSL	2
48	Stand Alone Facility	EMS Post 9	EMS	1010 N 143rd St E		ADSL	4
49	Stand Alone Facility	Emergency Operations Ctr (EOC)	EOC	401 S Tyler Rd	Wichita	ADSL	0
50	Stillwell	Voting Machine Service	Election Office	815 W Stillwell Ave	Wichita	50M	0
51	Stand Alone Facility	Environment Resources	Environment	2625 S Tyler Rd	Wichita	T1	10
52	Stand Alone Facility	Fire Post 31	Fire	5848 N 247th St W		ISDN	3
53	Stand Alone Facility	Fire Post 33	Fire	5728 N 151st St W		ISDN	2
54	Stand Alone Facility	Fire Post 34	Fire	3914 W 71st St S		ISDN	4
55	Stand Alone Facility	Fire Post 36	Fire	6400 S Rock Rd		ISDN	2
56	Stand Alone Facility	Fire Station 37 - Admin	Fire	4343 N Woodlawn Blvd	Bel Aire	T1	18
57	Stand Alone Facility	Fire Station 32/EMS Post 8	Fire/EMS	501 E 53RD St N	Park City	ADSL	4
58	Stand Alone Facility	Fire Station 35/EMS Post 7	Fire/EMS	651 S 247th St W		ISDN	3
59	Stand Alone Facility	Health - Admin	Health	1900 E 9th St N	Wichita	10M	81
60	Stand Alone Facility	Health - Behavioral Sciences	Health	714 S Hillside Ave	Wichita	ADSL	6
61	Stand Alone Facility	Health - Colvin	Health	2820 S Roosevelt Ave	Wichita	T1	13
62	Stand Alone Facility	Health - Department South	Health	434 N Oliver Ave	Wichita	T1	24
63	Stand Alone Facility	Health - Evergreen	Health	2700 N Woodland Ave	Wichita	ADSL	13
64	Stand Alone Facility	Health - Orchard	Health	4808 W 9th St N	Wichita	T1	0
65	Stand Alone Facility	Health - South East	Health	1530 S Oliver Ave	Wichita	T1	12
66	Stand Alone Facility	Health - Stanley	Health	1749 S Martinson Ave	Wichita	T1	12
68	Stand Alone Facility	Andale County Yard	Public Works	5858 N 247th St W		ISDN	2

# Wichita Area Regional ITS Architecture – Volume 3

SITEID	CAMPUS	SITENAME	DEPARTMENT	ADDRESS	CITY	NETWORK	NUMUSERS
69	Stillwell	Engineering	Public Works	1144 S Seneca Ave	Wichita	50M	0
70	Stillwell	Engineering	Public Works	1144 S Seneca Ave	Wichita	50M	0
71	Stillwell	Engineering	Public Works	1144 S Seneca Ave	Wichita	50M	0
72	Stillwell	Engineering	Public Works	1144 S Seneca Ave	Wichita	50M	0
73	Stillwell	Fleet Management	Public Works	1015 W Stillwell Ave	Wichita	50M	0
74	Stillwell	Hazardous Household Material	Public Works	801 W Stillwell Ave	Wichita	50M	0
75	Stand Alone Facility	Northeast County Yard	Public Works	10530 E 37th St N		ISDN	2
76	Stillwell	Noxious Weeds	Public Works	901 W Stillwell Ave	Wichita	50M	0
77	Stillwell	Public Works Admin	Public Works	1144 S Seneca Ave	Wichita	50M	106
78	Stillwell	Public Works Inspections	Public Works	1144 S Seneca Ave	Wichita	50M	0
79	Stillwell	Sign Shop	Public Works	815 W Stillwell Ave BLG 16	Wichita	50M	0
80	Stillwell	Signal Shop	Public Works	815 W Stillwell Ave BLG 16	Wichita	50M	0
81	Stand Alone Facility	Southeast County Yard	Public Works	2200 S Webb Rd		ISDN	2
82	Stand Alone Facility	Southwest County Yard	Public Works	4701 S West St		ISDN	2
83	Stillwell	Survey Department	Public Works	815 W Stillwell Ave BLG 16	Wichita	50M	0
84	Stand Alone Facility	Carlton Elementary Sheriff Sub	Sheriff	4900 S Clifton Ave		ISDN	0
85	Lake Afton	Lake Afton Gun Range	Sheriff	24516 W MacArthur Rd		ISDN	0
86	Lake Afton	Lake Afton Store	Sheriff	25401 W MacArthur Rd		ISDN	0
87	Stand Alone Facility	Sheriff - FBI	Sheriff	301 N Main St	Wichita	ADSL	2
88	Stillwell	Sheriff Gas Pumps	Sheriff	800 W Stillwell Ave	Wichita	50M	0
89	Stillwell	Sheriff Property & Evidence Heavyweight	Sheriff	830 W Stillwell Ave	Wichita	50M	0
90	Stillwell	Sheriff Property & Evidence Lightweight	Sheriff	830 W Stillwell Ave	Wichita	50M	0
91	Stillwell	Sheriff Squad Room	Sheriff	861 W Irving Ave	Wichita	ADSL	34
92	Lake Afton	Sheriff Substation	Sheriff	25401 W MacArthur Rd		ISDN	29
93	Lake Afton	Sheriff Training	Sheriff	25401 W MacArthur Rd		ISDN	0
94	Stand Alone Facility	Sheriff Training	Sheriff	2235 W 37th St N	Wichita	ADSL	36
95	Stand Alone Facility	Brittany Tag Office	Treasurer/Tag	2120 N Woodlawn Blvd	Wichita	T1	7
96	Stand Alone Facility	Chadworth Tag Office	Treasurer/Tag	2330 N Maize Rd	Wichita	T1	8
97	Stand Alone Facility	Derby Tag Office	Treasurer/Tag	206 W Greenway Blvd	Derby	T1	7
201	Main	Appraiser Annex	Appraiser	434 N Market ST	Wichita	1G	0
202	Main	Appraiser Annex	Appraiser	434 N Market ST	Wichita	1G	0
203	Main	Courthouse Appraiser Office	Appraiser	525 N Main ST	Wichita	1G	23
204	Main	Courthouse BOCC-MGR-COMM Offic	BOCC, Manager, Communications	525 N Main ST	Wichita	1G	40
205	Main	Wichita Data Center	City of Wichita	425 N Main ST	Wichita	10M	7
206	Main	Courthouse Clerk Office	Clerk	525 N Main ST	Wichita	1G	20
207	Main	Ark Valley Lodge - CDDO	CommCare	615 N Main ST	Wichita	1G	14
208	Main	CommCare Mental Health Waco	CommCare	940 N Waco ST	Wichita	1G	28
209	Main	Community Support Svcs (CSS)	CommCare	635 N Main St	Wichita	1G	6
210	Main	CommCare Admin	Commcare	635 N Main St	Wichita	1G	54
211	Main	Mental Health Crisis	Commcare	934 N Water ST	Wichita	1G	27
212	Main	Corrections	Corrections	905 N Main ST	Wichita	1G	70
213	Main	County Jail	Corrections	141 W Elm ST	Wichita	1G	155
214	Main	Courthouse DA Office	DA	525 N Main ST	Wichita	1G	91
215	Main	Munger Building	DIO	538 N Main ST	Wichita	1G	43
216	Main	Historic Courthouse	DIO (Data Center)	510 N Main ST	Wichita	1G	103
217	Main	Courthouse GIS Office	DIO-GIS	525 N Main ST	Wichita	1G	21
218	Main	Courthouse EOC/911 Center	EOC/911	525 N Main ST	Wichita	1G	30
219	Main	Historic Courthouse	Elections	510 N Main ST	Wichita	1G	25
220	Main	Courthouse Finance Dept.	Finance	525 N Main ST	Wichita	1G	28
221	Main	Historic Courthouse	Other Departments	510 N Main ST	Wichita	1G	36
222	Main	Courthouse Reg of Deeds Office	Registry of Deeds	525 N Main ST	Wichita	1G	33
223	Main	Ecco Plaza	Several Departments	604 N Main ST	Wichita	1G	18
224	Main	Courthouse Sheriff Dept.	Sheriff	525 N Main ST	Wichita	1G	12
225	Main	Courthouse Sheriff Dept.	Sheriff	525 N Main ST	Wichita	1G	31
226	Main	Courthouse Sheriff Dept.	Sheriff	525 N Main ST	Wichita	1G	11
227	Main	Courthouse Treasurer Dept.	Treasurer	525 N Main ST	Wichita	1G	50
228	Main	Mudock Tag Office	Treasurer	200 W Mudock	WICHITA	1G	0
236	Main	EMS - Via Christi	EMS	929 N St Francis Ave	Wichita	ADSL	0
239	Main	EMS Post 10	EMS	704 N Emporia Ave	Wichita	ADSL	2
240	Main	Adult Residential Facility	Corrections	622 E Central Ave	Wichita	T1	32